

ADRET ELECTRONIQUE®

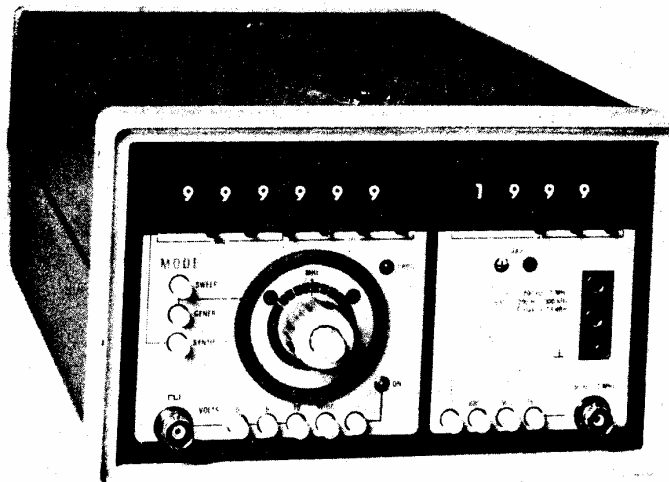
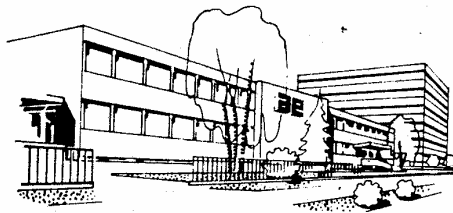

LEVEL GENERATOR
FREQUENCY SYNTHESIZER
50Hz - 1MHz

2230A

adret électronique
12, avenue Vladimir Komarov • BP 33 78192 Trappes Cedex • France • Tél. 051.29.72
Télex ADREL 697821 F • Siret 679805077 - 00014 • CCP Paris 21 797 04 •

SUMMARY

CHAPTER I	FUNCTIONAL DESCRIPTION	
CHAPTER II	SPECIFICATIONS	
CHAPTER III	PRINCIPLE OF OPERATION	
III-1	INTRODUCTION	III-1
III-2	PRINCIPLE OF THE 2230A SYNTHESIZER	III-2
CHAPTER IV	OPERATING INSTRUCTIONS	
IV-1	CONTROLS DESCRIPTION	IV-1
IV-2	INSTALLATION	IV-1
IV-3	OUTPUT FREQUENCY	IV-1
IV-3-1	Synthesizer mode	IV-1
IV-3-2	Generator mode	IV-1
IV-3-3	Sweeper mode	IV-3
IV-4	MAIN OUTPUT	IV-3
IV-4-1	75 Ω impedance	IV-3
IV-4-2	150 Ω impedance	IV-4
IV-4-3	600 Ω impedance	IV-4
IV-4-4	0 Ω /150 Ω impedance	IV-4
IV-4-5	0 Ω /600 Ω impedance	IV-4
IV-5	SQUARE WAVE OUTPUT	IV-4
IV-6	TRACKING OUTPUT	IV-4
IV-7	Z < 1 Ω AUXILIARY OUTPUT	IV-5
IV-8	ALC TIME CONSTANT	IV-6
IV-9	OUTPUT LEVEL INHIBITION	IV-6
IV-10	REFERENCE FREQUENCY	IV-6
IV-11	SUPPLY VOLTAGES OUTPUT	IV-6
IV-12	PARALLEL BCD PROGRAMMING (OPTION 010)	IV-7
IV-13	IEEE BUS PROGRAMMING (OPTION 020)	IV-8
IV-13-1	Addressing	IV-8
IV-13-2	Frequency programming	IV-9
IV-13-3	ALC time constant programming	IV-9
IV-13-4	Output level programming	IV-9
IV-13-5	Inhibition programming	IV-9
IV-13-6	Data enable	IV-9
IV-13-7	Programming examples	IV-10
IV-14	ADAPTATION TO 19" RACK	IV-11
APPENDIX	CHART OF ASCII CHARACTERS	
	IEEE BUS PROGRAMMING WITH CALCULATOR HP 9825A	

SUMMARY

CHAPTER V	CIRCUIT DESCRIPTION	
V-1	INTRODUCTION	V-1
V-2	GENERATION 10^0 Hz - 10^1 Hz - 10^2 Hz	V-1
V-3	GENERATION 10^3 Hz - 10^4 Hz - 10^5 Hz	V-5
V-4	DEMODULATOR-AMPLIFIER	V-9
V-5	OUTPUT LEVEL CODING	V-10
V-6	OUTPUT MODULE	V-12
V-7	$Z < 1 \Omega$ AMPLIFIER	V-13
V-8	PARALLEL BCD PROGRAMMING (OPTION 010)	V-13
V-9	IEEE BUS PROGRAMMING (OPTION 020)	V-13
V-9-1	IEEE bus isolator	V-14
V-9-2	IEEE bus registers	V-14
CHAPTER VI	MAINTENANCE	
CHAPTER VII	PLATES, SCHEMATICS, PARTS LIST	

LIST OF PLATES

III-1	PRINCIPE OF OPERATION
IV-1	FRONT-PANEL DESCRIPTION
IV-2	REAR-PANEL DESCRIPTION
IV-3	INTERNAL DESCRIPTION
V-1	BLOCK DIAGRAM
V-2	GENERATION 10^0 Hz - 10^1 Hz - 10^2 Hz
V-3	GENERATION 10^3 Hz - 10^4 Hz - 10^5 Hz
V-4	DEMODULATOR-AMPLIFIER
V-5	OUTPUT LEVEL CODING
V-6	OUTPUT MODULE
V-7	CONTROL CIRCUITS
V-8	POWER SUPPLY
V-9	$Z < 1 \Omega$ AMPLIFIER
V-10	IEEE BUS ISOLATOR
V-11	IEEE BUS REGISTERS
V-12	PARALLEL BCD PROGRAMMING

CHAPTER I
FUNCTIONAL DESCRIPTION

I FUNCTIONAL DESCRIPTION

The model 2230A is a programmable frequency and level generator which covers the 50 Hz to 1 MHz range with 1 Hz resolution.

The output frequency can be controlled according to four operating modes : digital setting by six lever/indicator switches, remote programming in parallel BCD code or through the IEEE bus, analogical setting by two verniers with graduated scale, frequency sweep by external signal.

Four output signals are simultaneously available :

- A main output with pushbutton selectable impedance : 75 Ω coaxial, 150 Ω balanced, 600 Ω balanced, or low-impedance balanced (key 0 Ω).
- An auxiliary output with $Z < 1 \Omega$ impedance.
- A square-wave output with 5 V or 10 V amplitude.
- A tracking output delivering a signal with 4 MHz offset with respect to the dialled or programmed frequency.

The output level of the main signal ranges from + 19.99 dBm to - 69.99 dBm for the 75 Ω impedance, and from + 13 dBm to - 69.99 dBm for the impedances with balanced output. The level setting is directly displayed in dBm into the selected impedance (75 Ω , 150 Ω or 600 Ω). Besides, an Inhibition key permits to suppress the output signal without switching off the instrument.

The frequency and level remote programming is achieved either in parallel BCD code (option 010), or through the IEEE bus (option 020). Besides, the output level regulation may be performed with two distinct time constants, which allows to reduce the level settling time to less than 10 ms for frequencies above 10 kHz.

CHAPTER II
SPECIFICATIONS

II SPECIFICATIONS

FREQUENCY

Main output :

- 75 Ω impedance : 50 Hz* to 1 MHz
- 150 Ω impedance : 200 Hz to 1 MHz
- 600 Ω impedance : 200 Hz to 300 kHz
- 0 Ω /150 Ω impedance : 200 Hz to 1 MHz
- 0 Ω /600 Ω impedance : 200 Hz to 300 kHz

Tracking output with 4 MHz offset : 4 MHz to 5 MHz

Square wave output : 50 Hz* to 1 MHz

Auxiliary output : 50 Hz* to 1 MHz

Resolution : 1 Hz

Selection : 6 lever/indicator switches

Stability : $\pm 3.10^{-6}/24$ h, from / 10°C to + 40°C.

* *This instrument can be used down to 10 Hz on the 75 Ω , square-wave and auxiliary outputs with some restrictions in the specifications.*

EXTERNAL REFERENCE

Substitution of the external reference for the built-in Master Oscillator.

Frequency : 5 MHz

Level : 220 mVrms to 1 Vrms/50 Ω

REFERENCE OUTPUT

Frequency : 1 MHz

Level : approximately 500 mVrms/50 Ω

FREQUENCY CONTINUOUS ADJUSTMENT

Frequency range : as for digital setting.

Frequency adjustment : by two verniers with graduated scale and by switches controlling the 1 Hz, 10 Hz and 100 Hz increments.

Dial accuracy : ± 5 % of full scale.

In this operating mode, the output frequency can be compared to the digital setting of the switches controlling the 1 kHz, 10 kHz and 100 kHz increments, thanks to a frequency comparator with LED display.

FREQUENCY SWEEP

Frequency range : same as for digital setting.

Sweep : By ± 5 V external signal.

- Input impedance : 100 k Ω
- Sensitivity : 10 mV_{peak} for 1 kHz deviation
- Linearity : ± 10 %
- Bandwidth :
 - DC to 500 Hz for ± 5 kHz deviation
 - DC to 50 Hz for ± 50 kHz deviation
 - DC to 5 Hz for ± 500 kHz deviation

In this operating mode, the center frequency around which the sweep is performed depends on the two verniers with graduated scale, as also on the switches controlling the 1 Hz, 10 Hz and 100 Hz increments.

Besides, the output frequency can be compared to the digital setting of the switches controlling the 1 kHz, 10 kHz and 100 kHz increments, thanks to a frequency comparator with LED display.

OUTPUT LEVEL

Several signals are simultaneously available :

- The main signal, delivered on the front panel with 0 Ω , 75 Ω , 150 Ω or 600 Ω impedance selected by pushbutton.
- A square-wave output, delivered on the front panel.
- A tracking signal with 4 MHz frequency offset, delivered on the rear panel.
- An auxiliary signal with very low output impedance, delivered on the rear panel.

Main output :

The main output is available with five pushbutton selectable impedances : 75 Ω coaxial, 150 Ω balanced, 600 Ω balanced, 0 Ω /150 Ω balanced ($Z < 5 \Omega$) and 0 Ω /600 Ω balanced ($Z < 20 \Omega$).

Level display : in dBm by four lever/indicator switches, with sign display by light-emitting diodes.

Resolution : 0.01 dB

Dynamic range : 89.98 dB for 75 Ω impedance and 82.99 dB for other impedances.

Output level :

- 75 Ω impedance : + 19.99 dBm to - 69.99 dBm/75 Ω
- 150 Ω impedance : + 13 dBm to - 69.99 dBm/150 Ω
- 600 Ω impedance : + 13 dBm to - 69.99 dBm/600 Ω
- 0 Ω /150 Ω impedance :

Electromotive force equal to that of 150 Ω impedance, that is 3.46 V_{rms} (+ 13 dBm setting) to 245 μ V_{rms} (- 69.99 dBm setting).

Maximum output current : 30 mA rms

- 0 Ω /600 Ω impedance :

Electromotive force equal to that of 600 Ω impedance, that is 6.92 V_{rms} (+ 13 dBm setting) to 490 μ V_{rms} (- 69.99 dBm setting).

Maximum output current : 15 mA rms

Accuracy at 0 dBm for a 10 kHz frequency : ± 0.2 dB

Output level flatness :

- 75 Ω impedance : + 0.05 dB from 50 Hz to 1 MHz
- 150 Ω and 0 Ω /150 Ω impedances : ± 0.05 dB from 200 Hz to 200 kHz
 ± 0.1 dB from 200 kHz to 620 kHz
 ± 0.2 dB from 620 kHz to 1 MHz
- 600 Ω and 0 Ω /600 Ω impedances : ± 0.05 dB from 200 Hz to 110 kHz
 ± 0.3 dB from 110 kHz to 300 kHz

Reflection loss :

- 75 Ω impedance : + 0 dBm to + 20 dBm : - 35 dB from 50 Hz to 1 MHz
- 0 dBm to - 69.99 dBm : - 45 dB from 50 Hz to 1 MHz
- 150 Ω impedance : - 35 dB from 200 Hz to 200 kHz
- 30 dB from 200 kHz to 1 MHz
- 600 Ω impedance : - 35 dB from 200 Hz to 110 kHz
- 30 dB from 110 kHz to 300 kHz

Signal unbalance :

- 150 Ω impedance : - 50 dB from 200 Hz to 620 kHz
- 600 Ω impedance : - 50 dB from 200 Hz to 110 kHz

Attenuator accuracy :

- 0.01 dB steps : ± 0.005 dB per step, ± 0.01 dB maximum error
- 0.1 dB steps : ± 0.01 dB per step, ± 0.02 dB maximum error
- 1 dB steps : ± 0.03 dB per step, ± 0.05 dB maximum error
- 10 dB steps : ± 0.1 dB per step, ± 0.2 dB maximum error from 0 dBm to - 60 dBm.

Tracking output :

Level : + 6 dBm/75 Ω ± 2 dB

Square-wave output :

- Amplitude : 0 V, 5 V or 10 V typical
- Rise time : < 300 ns
- Fall time : < 100 ns

Auxiliary output :

- Impedance : $Z < 1 \Omega$ from 50 Hz to 500 kHz
 $Z < 1.5 \Omega$ from 500 kHz to 1 MHz
- Level : + 19.99 dBm/75 Ω to 0 dBm/75 Ω , depending on main output level.

● Output current : 50 mA rms maximum

Protection against short-circuits.

- Maximum capacitive loading : 4.7 nF from 50 Hz to 500 kHz
1 nF from 500 kHz to 1 MHz

- Output level flatness : ± 0.5 dB from 50 Hz to 200 Hz
 ± 0.3 dB from 200 Hz to 1 MHz

SPECTRAL PURITY

Harmonic signals :

Main output (+ 10 dBm output level) :

- 75 Ω impedance : - 45 dB from 50 Hz to 300 Hz
- 55 dB from 300 Hz to 1 MHz
- 150 Ω and 0 Ω /150 Ω impedances : - 50 dB from 200 Hz to 1 MHz
- 600 Ω and 0 Ω /600 Ω impedances : - 50 dB from 200 Hz to 300 kHz

Auxiliary output (+ 10 dBm/75 Ω output level) : - 40 dB from 50 Hz to 300 Hz
- 50 dB from 300 Hz to 1 MHz

Nonharmonic signals : - 60 dB for all outputs

Phase-noise in a 1 Hz band :

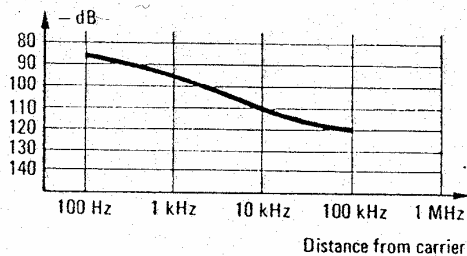

REMOTE PROGRAMMING

Remote programming of the instrument is achieved either in parallel BCD code (option 010) or through the IEEE bus (option 020).

Parallel BCD programming (option 010) :

- TTL compatible positive logic. "0" logic level : 0 V to + 0.8 V
"1" logic level : + 2 V to + 5 V
- Parallel BCD code.

IEEE bus programming (option 020) :

Compatible with IEEE standard 488-1975.

SH0 : the instrument never emits data.

AH1 : the instrument accepts data.

TO-TE0 : the instrument is not a Talker.

L1-LE0 : the instrument is a basic Listener which recognizes its own address, does not get disaddressed on reception of the corresponding Talker address, and may be permanently addressed.

SRO : the instrument has no Service Request capability.

PP0 : the instrument does not respond to Parallel Poll.

RL1 : the Remote mode is controlled through the IEEE bus.

DC1 : the instrument has complete Device Clear capability.

DT1 : the instrument has complete Device Trigger capability.

Frequency programming :

- Resolution : 1 Hz
- Settling time : 10^3 Hz to 10^5 Hz steps : 7 ms
 10^0 Hz to 10^2 Hz steps : 10 ms.

Level programming :

- Resolution : 0.01 dB
- Settling time : 10 dB steps between - 0 dBm and - 60 dBm : 10 ms

Switching between + 0 dBm and + 10 dBm, 1 dB, 0.1 dB and 0.01 dB steps :

5 ms with ALC time constant $F > 10$ kHz, 800 ms with ALC time constant $F < 10$ kHz.

Functional mode programming :

- Local/Prog.
- Output level inhibition
- ALC time constant

POWER REQUIREMENTS

Voltage : 115 V or 230 V (± 10 %)

Frequency : 50 Hz to 400 Hz

Consumption : 20 VA

Dimensions :

Height : 140 mm

Width : 200 mm

Overall depth : 352 mm

Adaptable to 19" rack (3 U)

Temperature range :

Operation : 0°C to $+ 50^{\circ}\text{C}$

Storage : $- 20^{\circ}\text{C}$ to $+ 70^{\circ}\text{C}$

Weight : 6 kg

III PRINCIPLE OF OPERATION

III-1 INTRODUCTION

The operation of ADRET synthesizers is based on the indirect frequency synthesis, making use of phase-locked loops composed of a voltage-controlled oscillator, a programmable counter and a phase comparator, as shown in figure III-1.

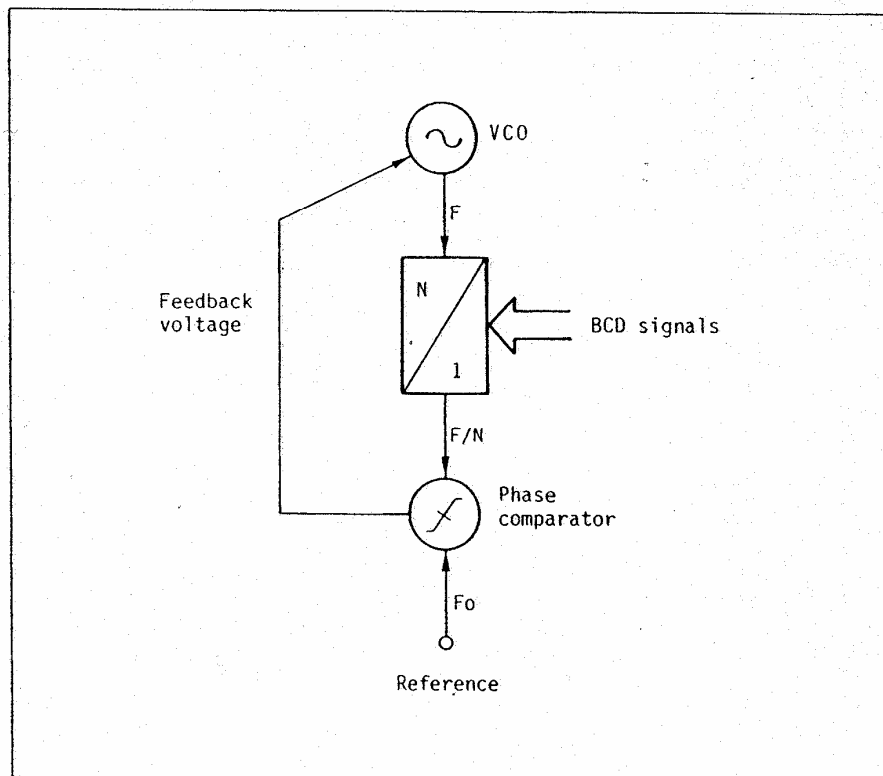

Figure III-1 PHASE-LOCKED LOOP PRINCIPLE

The F frequency delivered by the oscillator is applied to the programmable counter, the N division rate of which is controlled by BCD programming signals. The F/N frequency provided by the programmable counter is then compared to an F_0 reference frequency in the phase comparator, which gives a phase-locking voltage allowing to maintain the F frequency of the oscillator equal to N times the F_0 reference.

Such a phase-locked loop can thus generate ten different frequencies multiple of F_0 when the N division rate of the programmable counter has ten different values.

III-2 PRINCIPLE OF THE 2230A SYNTHESIZER

The general principle of the 2230A synthesizer is represented in plate III-1.

The elaboration of the synthesizer output frequency is achieved through two phase-locked loops : the first loop generates the 10^0 Hz, 10^1 Hz and 10^2 Hz increments of the output frequency, while the second loop generates the 10^3 Hz, 10^4 Hz and 10^5 Hz increments. In the Generator and Sweeper modes, the phase-locking voltage which controls the oscillator of the second loop is replaced by a DC voltage issued from verniers (P1), upon which an external voltage applied to connector (J7) may be superimposed in Sweeper mode.

The mixing of the frequencies elaborated by the two phase-locked loops provides a signal ranging from 4 MHz to 5 MHz in 1 Hz steps, that constitutes the tracking output with 4 MHz offset available on connector (J4). This signal is then heterodyned down in the output mixer with a 4 MHz frequency, which provides a 10 Hz to 1 MHz signal. After amplification, this signal is fed to the shaper delivering the square wave available on connector (J3), to the amplifier of the $Z < 1 \Omega$ auxiliary output, and to an attenuator followed with an impedance transformer providing various impedances (75 Ω coaxial, 0 Ω balanced, 150 Ω balanced or 600 Ω balanced) to the main output.

The level of the main output is adjustable from - 69.99 dBm to + 19.99 dBm with 0.01 dB resolution through a digital-to-analog converter which acts upon the ALC loop and varies the level of the 4 MHz signal in 0.01 dB, 0.1 dB and 1 dB steps, whereas the output attenuator provides up to 70 dB attenuation in 10 dB steps.

CHAPTER IV
OPERATING INSTRUCTIONS

IV OPERATING INSTRUCTIONS

IV-1 CONTROLS DESCRIPTION

The various controls and connections on the front and rear panels of the 2230A synthesizer are described in the two following plates :

Plate IV-1 : Front-panel description.

Plate IV-2 : Rear-panel description.

IV-2 INSTALLATION

Connection to mains is achieved on socket (S02) through a standard cord supplied with the instrument. Before applying power, check that mains voltage selector (K8) is on the position corresponding to the mains voltage, remembering that the 115 V and 230 V values admit $\pm 10\%$ variation.

The instrument is protected against short-circuits by fuse (F1) of 150 mA nominal value for a 230 V mains voltage, or 300 mA for a 115 V mains voltage.

Switching on the instrument is achieved by pressing key (K1), which lights up indicator (DS1).

IV-3 OUTPUT FREQUENCY

In Local mode, the output frequency can be controlled in three different ways selected by keyboard (K3) : Synthesizer mode, Generator mode, Sweeper mode.

IV-3-1 SYNTHESIZER MODE

In this operating mode, selected by pressing the "SYNTH." key of keyboard (K3), the output frequency is digitally set through lever/indicator switches (K2).

IV-3-2 GENERATOR MODE

This operating mode is obtained by pressing the "GENER." key of keyboard (K3).

The output frequency is determined both by the two verniers (P1) and by the (K2) switches controlling the 1 Hz, 10 Hz and 100 Hz frequency steps, whereas the three other (K2) switches are inhibited.

Two light-emitting diodes (DS3) allow to compare the output frequency to the digital display of switches (K2), this comparison being performed with the three switches controlling the 1 kHz, 10 kHz and 100 kHz frequency steps.

When the output frequency is superior to the digital display of switches (K2), the right-hand LED lights up and the left-hand LED goes out. On the contrary, the left-hand LED lights up and the right-hand LED goes out if the output frequency is inferior to the digital display. When the output frequency is approximately equal to the digital display of switches (K2), a very slow blinking of one LED is observed.

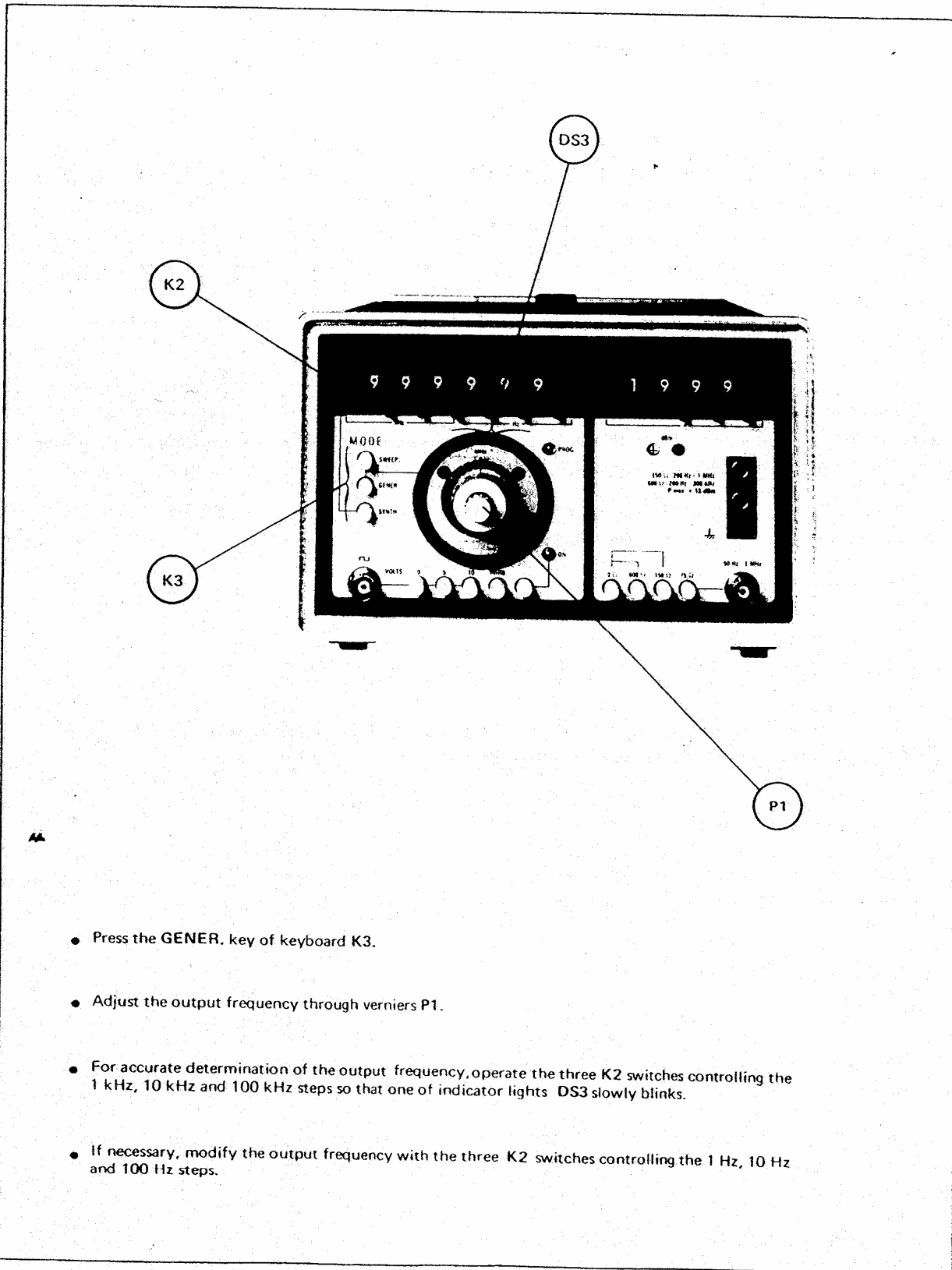

- Press the GENER. key of keyboard K3.
- Adjust the output frequency through verniers P1.
- For accurate determination of the output frequency, operate the three K2 switches controlling the 1 kHz, 10 kHz and 100 kHz steps so that one of indicator lights DS3 slowly blinks.
- If necessary, modify the output frequency with the three K2 switches controlling the 1 Hz, 10 Hz and 100 Hz steps.

Figure IV-1 GENERATOR MODE

IV-3-3 SWEEPER MODE

This operating mode, selected by pressing the "SWEEP." key of keyboard (K3), differs from the Generator mode only in the possibility to sweep the output signal around the frequency selected by verniers (P1) and by the (K2) switches controlling the 1 Hz, 10 Hz and 100 Hz frequency steps.

The frequency sweep is achieved by applying an external voltage to connector (J7) whose input sensitivity is 100 kHz per volt. As shown in figure IV-2, the entire frequency range can be swept by a 10 Vp-p signal with a DC offset depending on the setting of verniers (P1).

For instance, if verniers (P1) are set to 0.2 MHz, sweeping the entire frequency range is achieved by applying a signal with 10 Vp-p amplitude centered on + 3 V.

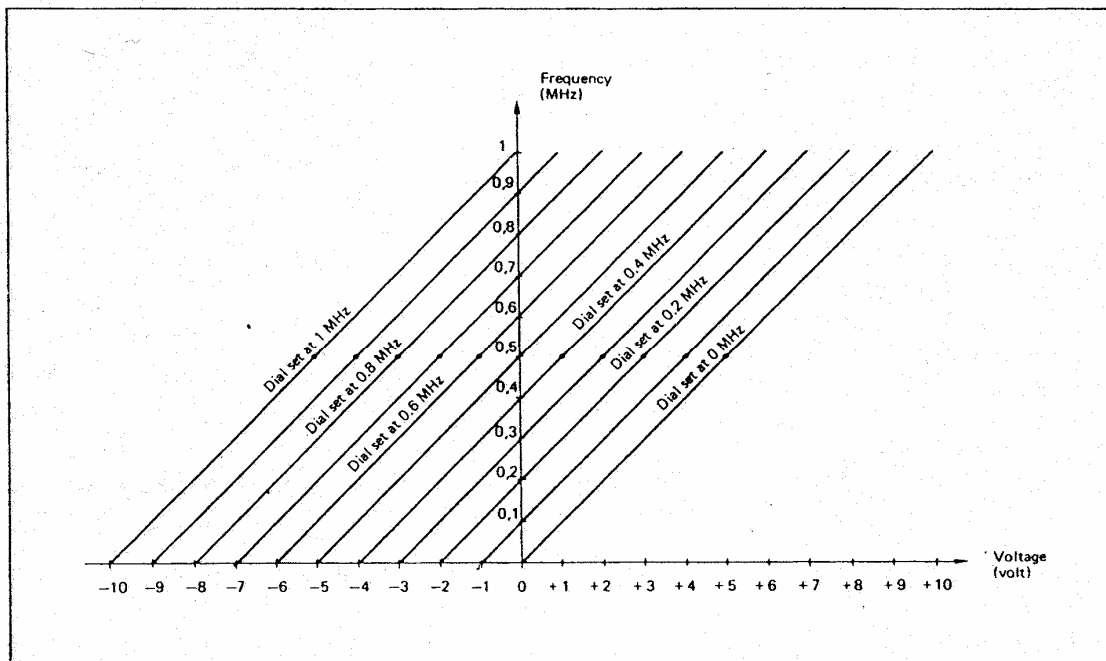

Figure IV-2 OUTPUT FREQUENCY SWEEP

As in the Generator mode, the (DS3) light-emitting diodes allow to compare the output frequency to the digital display of switches (K2), this comparison being performed with the three switches controlling the 1 kHz, 10 kHz and 100 kHz frequency steps.

IV-4 MAIN OUTPUT

Depending on the impedance selected on keyboard (K5), the main output signal is delivered either on coaxial connector (J1) or on balanced connector (J2).

IV-4-1 75 Ω IMPEDANCE

This impedance is selected by pressing the "75 Ω " key of keyboard (K5). The output signal is available on coaxial connector (J1) and the output level is digitally set in dBm/75 Ω through switches (K4), with sign display provided by indicator lights (DS4).

The usable frequency range goes from 10 Hz to 1 MHz, while the output level ranges from + 19.99 dBm (2.735 Vrms/75 Ω) to - 69.99 dBm (86.7 μ Vrms/75 Ω) with 0.01 dB resolution.

IV-4-2 150 Ω IMPEDANCE

This impedance is selected by pressing the "150 Ω " key of keyboard (K5). The output signal is available on balanced connector (J2) and the output level is digitally set in dBm/150 Ω through switches (K4), with sign display provided by indicator lights (DS4).

The usable frequency range goes from 200 Hz to 1 MHz, while the output level ranges from + 13 dBm (1.730 Vrms/150 Ω) to - 69.99 dBm (122.6 μ Vrms/150 Ω) with 0.01 dB resolution.

IV-4-3 600 Ω IMPEDANCE

This impedance is selected by pressing the "600 Ω " key of keyboard (K5). The output signal is available on balanced connector (J2) and the output level is digitally set in dBm/600 Ω through switches (K4), with sign display provided by indicator lights (DS4).

The usable frequency range goes from 200 Hz to 300 kHz, while the output level ranges from + 13 dBm (3.460 Vrms/600 Ω) to - 69.99 dBm (245.2 μ Vrms/600 Ω) with 0.01 dB resolution.

IV-4-4 0 Ω /150 Ω IMPEDANCE

When both the "0 Ω " and "150 Ω " keys are pressed, connector (J2) delivers a signal with less than 5 Ω output impedance. The electromotive force of this signal is equal to that of the signal with 150 Ω output impedance, that is twice the level displayed in dBm/150 Ω by switches (K4) and indicator lights (DS4).

The usable frequency range goes from 200 Hz to 1 MHz, while the electromotive force ranges from 3.46 Vrms (+ 13 dBm/150 Ω display) to 245 μ Vrms (- 69.99 dBm/150 Ω display) in 0.01 dB steps.

IV-4-5 0 Ω /600 Ω IMPEDANCE

When both the "0 Ω " and "600 Ω " keys are pressed, connector (J2) delivers a signal with less than 20 Ω output impedance. The electromotive force of this signal is equal to that of the signal with 600 Ω output impedance, that is twice the level displayed in dBm/600 Ω by switches (K4) and indicator lights (DS4).

The usable frequency range goes from 200 Hz to 300 kHz, while the electromotive force ranges from 6.92 Vrms (+ 13 dBm/600 Ω display) to 490 μ Vrms (- 69.99 dBm/600 Ω display) in 0.01 dB steps.

IV-5 SQUARE-WAVE OUTPUT

Coaxial connector (J3) delivers a square wave with the same frequency as the main output signal and with 0 V, 5 V or 10 V amplitude selected on keyboard (K7). The "low" level of this square wave is 0V, which makes it compatible with TTL and C-MOS logical circuits.

IV-6 TRACKING OUTPUT

Coaxial connector (J4) permanently delivers a sinusoidal signal with + 6 dBm/75 Ω output level and 4 MHz frequency offset from the main output signal.

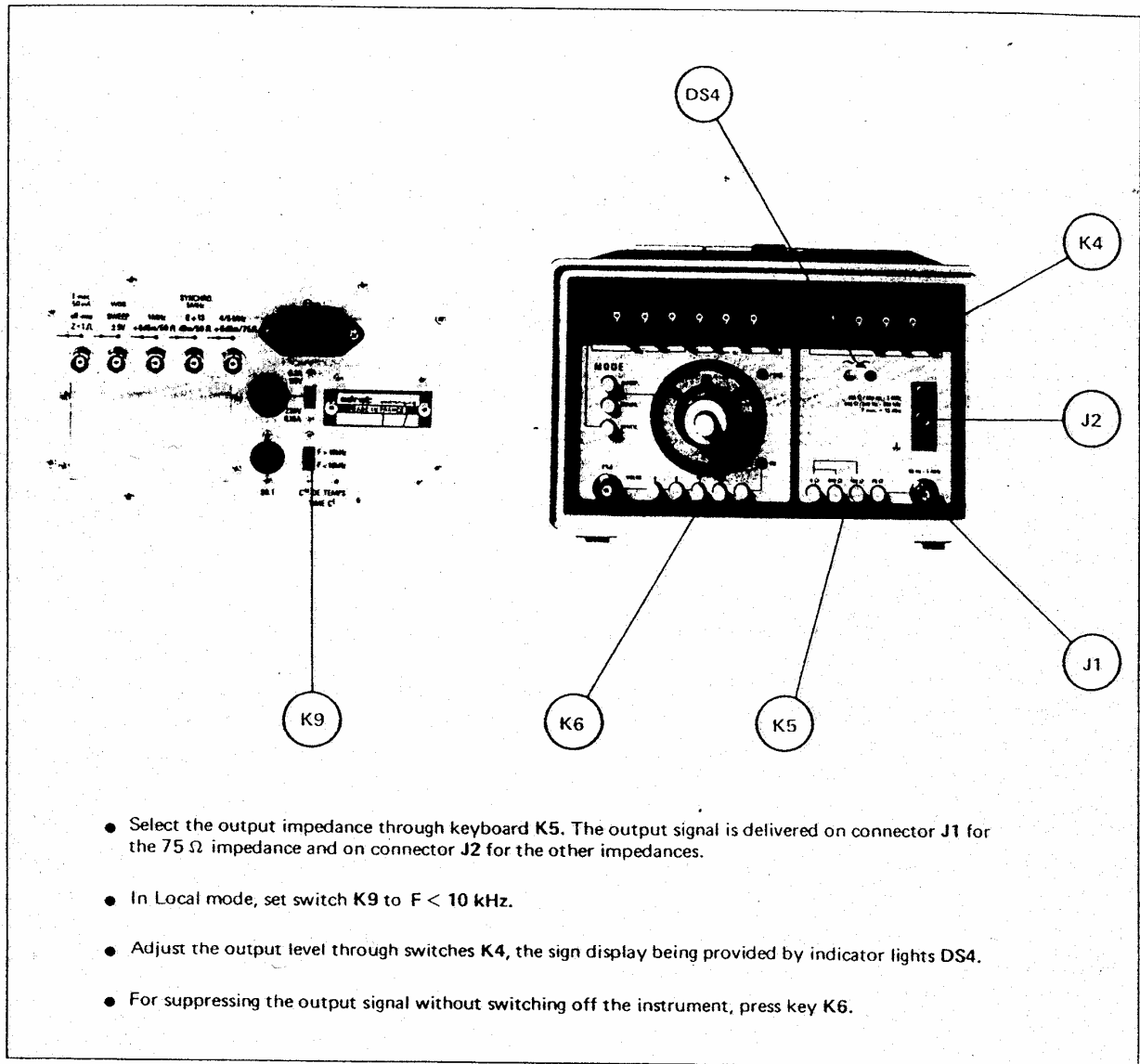

Figure IV-3 MAIN OUTPUT

IV-7 Z < 1 Ω AUXILIARY OUTPUT

A sinusoidal signal with less than 1 Ω output impedance and with the same frequency as the main output signal is available on coaxial connector (J8).

When the level setting of switches (K4) ranges from + 0 dBm to + 19.99 dBm, the electromotive force of this signal is equal to the level of the main output signal expressed in dBm/75 Ω .

When the level setting of switches (K4) ranges from - 0 dBm to - 69.99 dBm, the electromotive force varies from + 10 dBm/75 Ω to + 0.01 dBm/75 Ω according to the table below.

Setting of switches K4	- 0.00	- 9.99	- 10.00	- 19.99	- 20.00	- 29.99	- 30.00	- 39.99	- 40.00	- 49.99	- 50.00	- 59.99	- 60.00	- 69.99
Electromotive force in dBm/75 Ω	+ 10	+ 10	+ 10	+ 10	+ 10	+ 10	+ 10	+ 10	+ 10	+ 10	+ 10	+ 10	+ 10	+ 10
		+ 0.01	+ 0.01	+ 0.01	+ 0.01	+ 0.01	+ 0.01	+ 0.01	+ 0.01	+ 0.01	+ 0.01	+ 0.01	+ 0.01	+ 0.01

IV-8 ALC TIME CONSTANT

In order to optimize the output level settling time, this instrument is endowed with two ALC time constants selected through rear-panel switch (K9). The longer time constant provides level regulation over the entire frequency range ($F < 10$ kHz setting), whereas the other is reserved for frequencies higher than 10 kHz ($F > 10$ kHz setting).

In Local mode, it is well-advised to always set switch (K9) to the $F < 10$ kHz setting, which allows operation with any output frequency.

IV-9 OUTPUT LEVEL INHIBITION

Pressing front-panel key (K6) permits to suppress the main output signal, the Z < i auxiliary output signal and the square-wave signal without switching off the instrument.

IV-10 REFERENCE FREQUENCY

The 1 MHz reference frequency derived from the internal crystal oscillator is permanently available on connector (J6) with approximately 500 mVrms/50 Ω output level.

This internal crystal oscillator can be synchronized to a 5 MHz external reference signal applied to connector (J5) with 220 mVrms to 1 Vrms/50 Ω input level. In that case, the frequency delivered by the various outputs of the synthesizer has the stability of the reference frequency applied to connector (J5).

IV-11 SUPPLY VOLTAGES OUTPUT

Socket (S01), whose pin assignment is indicated in figure IV-4, provides + 12 V, + 6 V and - 12 V regulated voltages destined to external circuits.

Maximum current for each voltage : 100 mA.

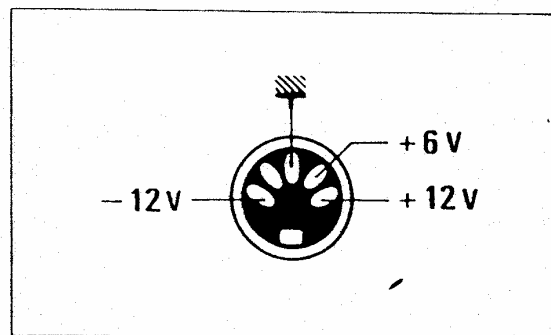

Figure IV-4 SOCKET (S01)

IV-12 PARALLEL BCD PROGRAMMING (OPTION 010)

Selection of the remote programming mode is achieved by applying a "0" logic level to pin 17 of connector (S03), which lights up indicator (DS2). All manual controls are then inhibited, save on/off switch (K1), impedance selection keyboard (K5), square-wave selection keyboard (K7), and mains voltage selector (K8).

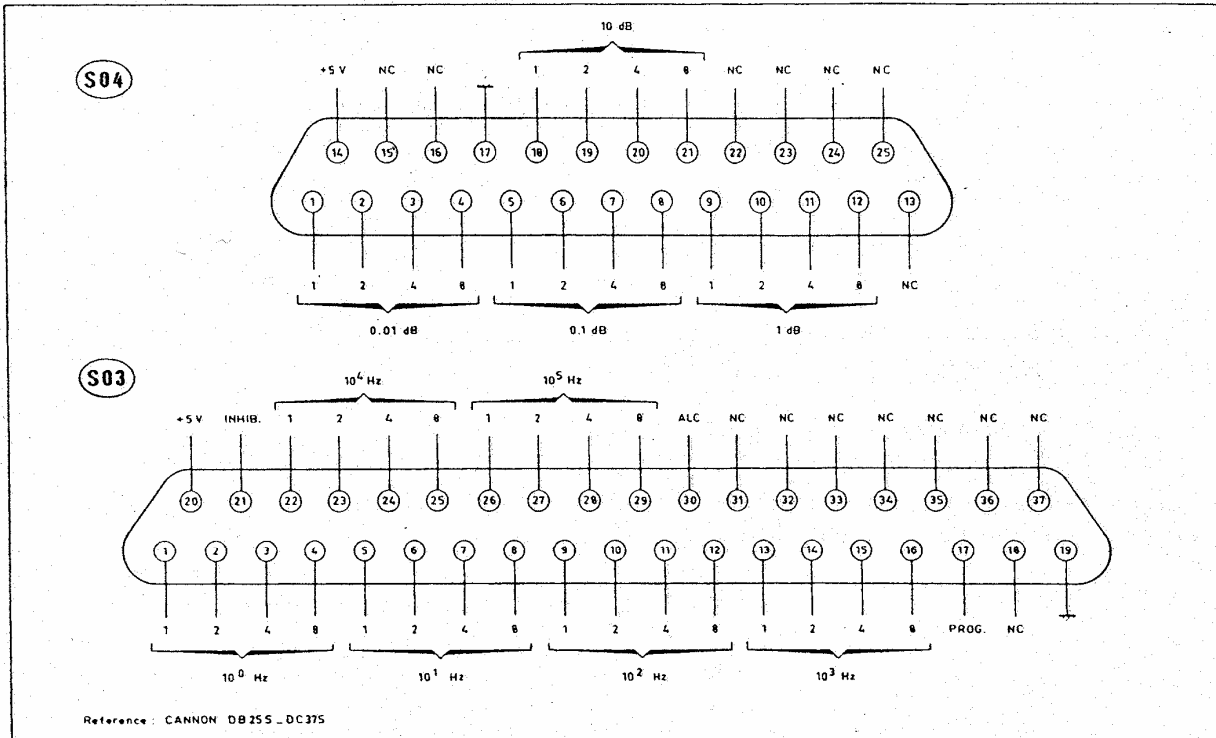

Figure IV-5 PARALLEL BCD PROGRAMMING CONNECTORS

The synthesized frequency programming is achieved in positive logic through TTL compatible signals applied to connector (S03) whose pin assignment is indicated in figure IV-5.

The output level is determined by programming the attenuation with respect to + 20 dBm. This attenuation programming is achieved in positive logic through TTL compatible signals applied to connector (S04). For instance, programming 9.32 dB provides + 10.68 dBm output level to the main signal.

The output level inhibition is obtained by applying a "0" logic level to pin 21 of connector (S03).

The ALC time constant programming is performed on pin 30 of connector (S03), a "0" logic level corresponding to $F < 10$ kHz and a "1" logic level corresponding to $F > 10$ kHz. The $F < 10$ kHz time constant may be selected with any output frequency, whereas the $F > 10$ kHz time constant is destined to the fast level switching of frequencies above 10 kHz.

Pin 20 of connector (S03) and pin 14 of connector (S04) continuously provide a + 5 V regulated voltage which can facilitate programming and be used as a pilot of the instrument operation (50 mA maximum current).

The input circuit of the programming signals consists of a 40097 buffer preceded with a 1N 4448 diode as shown in figure IV-6.

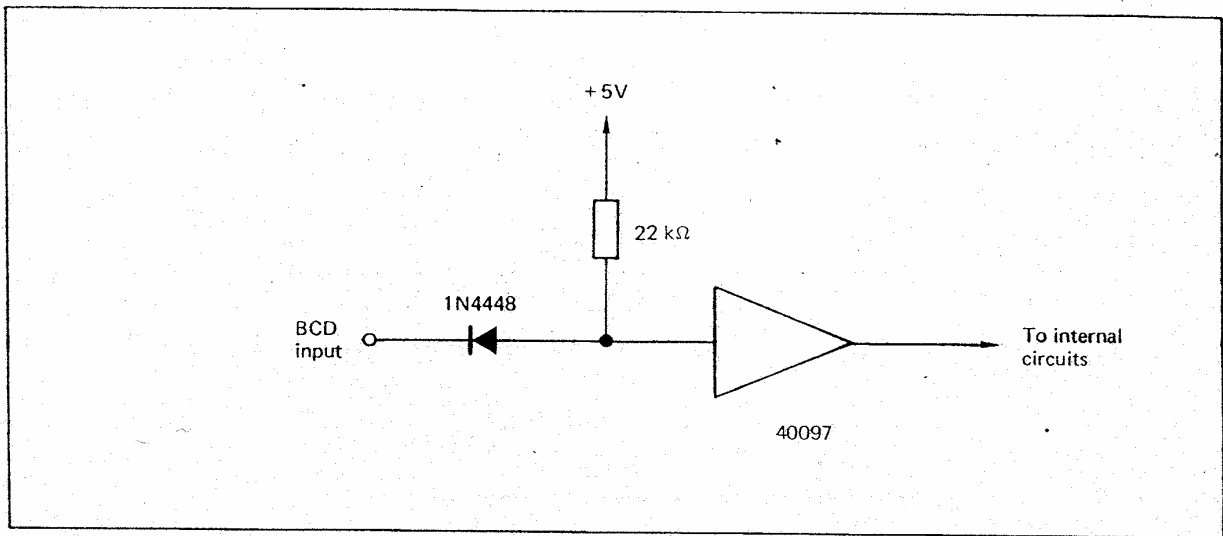

Figure IV-6 PROGRAMMING SIGNALS INPUT CIRCUIT

IV-13 IEEE BUS PROGRAMMING (OPTION 020)

The synthesizer programming through the IEEE bus is achieved in accordance with IEEE standard 488-1975 on connector (S05) whose pin assignment is indicated in figure IV-7.

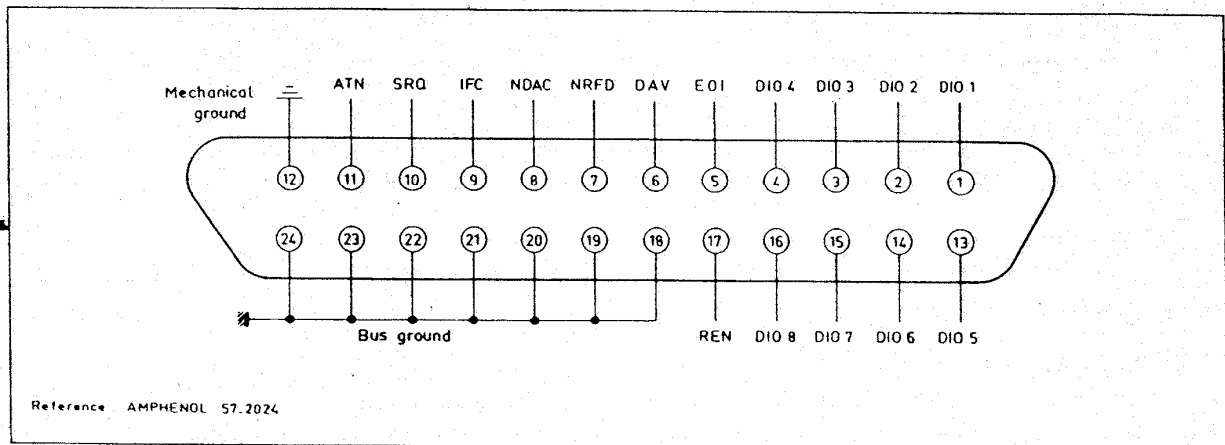

Figure IV-7 IEEE BUS CONNECTOR

IV-13-1 ADDRESSING

The instrument address is selected in binary code among numbers 0 to 30 through five digital switches (K10). This address is enabled by setting digital switch (K11) to "Addressable".

When switch (K11) is set to "Listen only", the instrument operates in continuous addressing.

Immediately after being addressed, the instrument goes to remote programming mode, which lights up indicator (DS2). The return to Local mode requires either reception of the GTL order (Go To Local), presence of a "1" logic level on line REN, or presence of a "0" logic level on line IFC.

In remote programming mode, all manual controls are inhibited, save on/off switch (K1), impedance selection keyboard (K5), square-wave selection keyboard (K7), and mains voltage selector (K8).

IV-13-2 FREQUENCY PROGRAMMING

The synthesized frequency programming is achieved by sending letter F followed with a whole number representing the frequency in Hz. If the transmitted number comprises a point, a comma, or more generally any character other than a figure, the figures sent after this character are ignored. This particularly prohibits the use of the floating point format.

Several characters may be inserted between letter F and the number representing the synthesized frequency. These characters are ignored by the instrument, provided that they are neither letter A, order CR (Carriage Return), or one of signs < and >.

IV-13-3 ALC TIME CONSTANT PROGRAMMING

Changing the ALC time constant is achieved by inserting sign < or > between letter F and the number representing the synthesized frequency, the < sign corresponding to F < 10 kHz and the > sign corresponding to F > 10 kHz. Without sign < or > inserted between letter F and the number representing the synthesized frequency, the ALC time constant remains unchanged.

The F < 10 kHz time constant may be selected with any output frequency, whereas the F > 10 kHz time constant is destined to the fast level switching of frequencies above 10 kHz.

IV-13-4 OUTPUT LEVEL PROGRAMMING

The output level is determined by programming the attenuation with respect to + 20 dBm. This attenuation programming is achieved by sending letter A followed with a whole number representing the attenuation in mB (0.01 dB). If the transmitted number comprises a point, a comma, or more generally any character other than a figure, the figures sent after this character are ignored by the instrument.

Several characters may be inserted between letter A and the number representing the output level attenuation. These characters are ignored by the instrument, provided that they are neither letter F, order CR (Carriage Return), or question mark ?.

IV-13-5 INHIBITION PROGRAMMING

The output level inhibition is programmed by sending letter A followed with question mark ?. This inhibition ends as soon as another attenuation is programmed.

IV-13-6 DATA ENABLE

The data received by the synthesizer are taken into account only after reception of order CR (Carriage Return), often sent automatically by the calculator at the end of the message, or order GET (Group Executive Trigger) that permits to simultaneously enable the data received by several instruments.

Inversely, orders A and F may be cancelled by sending either order DCL (Device Clear) or order SDC (Selective Device Clear).

IV-13-7 PROGRAMMING EXAMPLES

In the following examples, it is assumed that the instrument has been addressed and that the message ends by order CR (Carriage Return).

F < 1 9 7 8 A 0

Frequency 1978 Hz.
Time constant F < 10 kHz.
Level + 20 dBm.

F 2 0 0 0

Frequency 2000 Hz.
Time constant unchanged.
Level unchanged.

F R E Q U 5 2 5

Frequency 525 Hz (letters REQU and space are ignored).
Time constant unchanged.
Level unchanged.

F 1 5 0 0 . 3 5

F 1 5 0 0 , 3 5

F 1 5 0 0 3 5

Frequency 1500 Hz (the figures placed after the point, comma or space are ignored).
Time constant unchanged.
Level unchanged.

F > 5 9 2 8 1 A ?

Frequency 59281 Hz.
Time constant F > 10 kHz.
Level inhibition.

A 9 5 1

Frequency unchanged.
Time constant unchanged.
Level + 10.49 dBm (9.51 dB attenuation).

A T T E N . 9 5 1

Frequency unchanged.
Time constant unchanged.
Level + 10.49 dBm (letters TTEN and point are ignored).

A 9 5 1 . 2 5

A 9 5 1 , 2 5

A 9 5 1 2 5

Frequency unchanged.
Time constant unchanged.
Level + 10.49 dBm (the figures placed after the point, comma or space are ignored).

F < 5 0 0 0 A T T E N 9 5 1

Frequency 5000 Hz.
Time constant F < 10 kHz.
Level 10.49 dBm (letters TTEN are ignored).

F A 1 0 0 0

Frequency 1000 Hz.
Time constant unchanged.
Level + 10 dBm (10.00 dB attenuation).

IV-14 ADAPTATION TO 19" RACK

The synthesizer 2230 A can be incorporated in a 19" rack with the help of a cabinet reference 01 22309001 for the incorporation of one instrument, or reference 01 22309002 for the incorporation of two instruments. The procedure for inserting the 2230 A in either of these cabinets is as follows.

- Remove the four rear-panel screws holding the top and bottom covers.

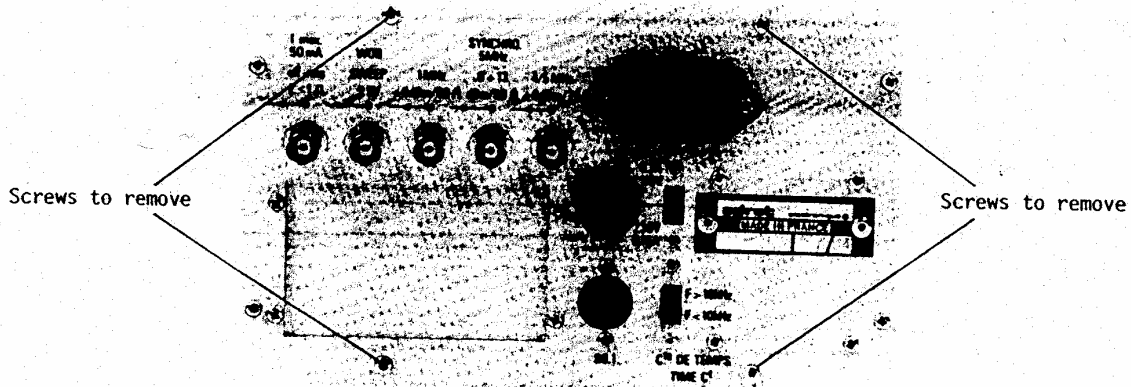

- Pull out these two covers.
- Take off the top-cover handle (four screws to remove).
- Take off the four feet of the bottom cover.
- Set the covers back in their place without fixing them.
- Insert the 2230 A in the cabinet and screw back the four rear-panel screws.

APPENDIX

CHART OF ASCII CHARACTERS

BITS				b7 b6 b5	0 0	0 0	0 1	0 1	1 0	1 0	1 1	1 1
b4	b3	b2	b1	Column Row	0	1	2	3	4	5	6	7
0	0	0	0	0	NUL	DLE		0	ⓐ	P	\	p
0	0	0	1	1	SOH	DC1	!	1	A	Q	a	q
0	0	1	0	2	STX	DC2	"	2	B	R	b	r
0	0	1	1	3	ETX	DC3	#	3	C	S	c	s
0	1	0	0	4	EOT	DC4	\$	4	D	T	d	t
0	1	0	1	5	ENQ	NAK	%	5	E	U	e	u
0	1	1	0	6	ACK	SYN	&	6	F	V	f	v
0	1	1	1	7	BEL	ETB	'	7	G	W	g	w
1	0	0	0	8	BS	CAN	(8	H	X	h	x
1	0	0	1	9	HT	EM)	9	I	Y	i	y
1	0	1	0	10	LF	SUB	.	:	J	Z	j	z
1	0	1	1	11	VT	ESC	+	;	K	[k	;
1	1	0	0	12	FF	FS	,	<	L	\	l	:
1	1	0	1	13	CR	GS	-	=	M]	m	;
1	1	1	0	14	SO	RS	.	>	N	^	n	~
1	1	1	1	15	SI	US	/	?	O	_	o	DEL

IEEE BUS PROGRAMMING WITH CALCULATOR HP 9825A

```

0: "2230A programming with calculator HP9825":
1: "the instrument address is assumed to be 0":
2:
3: fmt 2f.0
4: ent "Frequency in Hertz",F
5: if F<10 or F>=1e6;dsp "Frequency out of range";gto "stop"
6: ent "Level in dBm",A
7: if A>20 or A<=-70;dsp "Level out of range";gto "stop"
8: if F<=4;wrt 700,"F<","F","A",2000-100*A;gto 4
9: wrt 700,"F>","F","A",2000-100*A;gto 4
10: "stop":wrt 700,"A?";wait 1000;gto 4
11: end
    
```

CHAPTER V
CIRCUIT DESCRIPTION

V-1 INTRODUCTION

In all the schematics and figures of the present manual, the various circuits making up the instrument are designated by the following abbreviations :

- A Amplifier, buffer or shaper
- CP Phase comparator
- D Frequency divider
- DP Programmable frequency divider
- DT Level detector
- FL Filter
- M Mixer
- O Oscillator

V-2 GENERATION 10^0 Hz - 10^1 Hz - 10^2 Hz

Refer to block diagram in plate V-1 and figure V-1, and schematic in plate V-2.

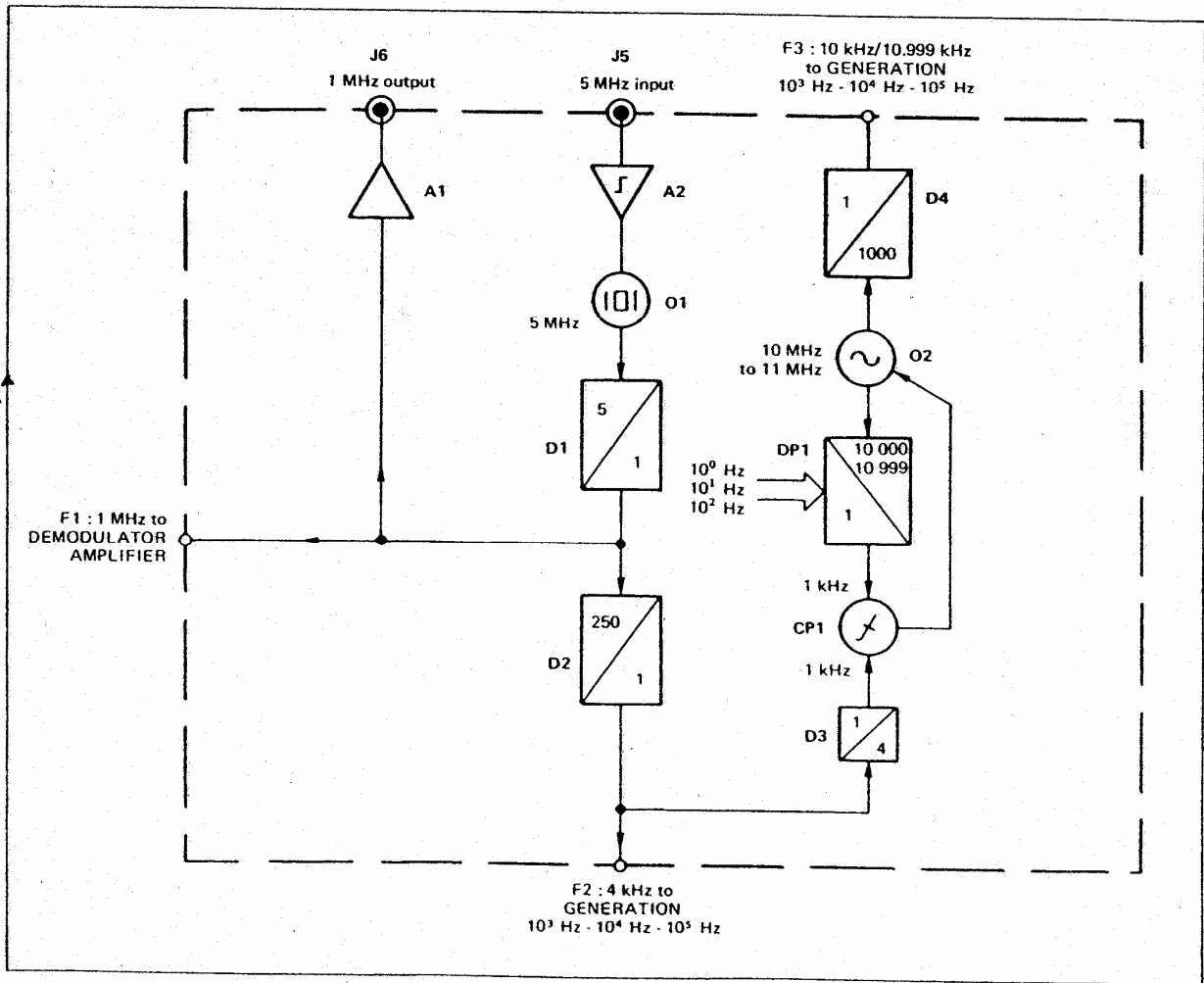

Figure V-1 GENERATION 10^0 Hz - 10^1 Hz - 10^2 Hz

This subassembly includes a phase-locked loop generating the 10^0 Hz, 10^1 Hz and 10^2 Hz increments of the output frequency, and the synthesizer time base.

The time base comprises crystal oscillator O2 which may be synchronized on an external 5 MHz frequency reference with 0 dBm to + 13 dBm/50 Ω input level thanks to shaper A2. The 5 MHz output frequency of oscillator O1 is divided by 5 in divider O1 in order to provide frequency F1 : 1 MHz required by the Demodulator Amplifier, and available on connector (J6) at a level of about + 6 dBm/50 Ω after amplification by A1. This frequency is then divided by 250 in divider O2 which delivers frequency F2 : 4 kHz to the Generation 10^3 Hz - 10^4 Hz - 10^5 Hz subassembly.

The phase-locked loop generating the 10^0 Hz, 10^1 Hz and 10^2 Hz increments of the output frequency includes oscillator O2, programmable counter DP1 and phase comparator CP1. Oscillator O1 generates a 10 MHz to 10.999 MHz frequency which is divided by the division rate N : 10 000 to 10 999 of programmable counter DP1. The output frequency of counter DP1 is then compared in phase comparator CP1 with a 1 kHz reference obtained by dividing frequency F2 : 4 kHz by 4 in divider D3. Phase comparator CP1 therefore provides a DC voltage which locks oscillator O1 onto a frequency equal to N times the reference frequency of 1 kHz.

The frequency generated by oscillator O1 is divided by 1000 in divider D4, which provides frequency F3 : 10 kHz/10.999 kHz routed to the Generation 10^3 Hz - 10^4 Hz - 10^5 Hz subassembly.

PRINCIPLE OF PROGRAMMABLE COUNTER DP1

Programmable counter DP1 includes two dividers with a division rate of 10 or 11, a divider with a division rate of 100 to 109, and two binary module comparators controlling respective dividers by 10 or 11.

During a count cycle, the front divider divides P times by 11, where P is the value of the 10^0 Hz digit programmed in positive logic on the corresponding binary module comparator (integrated circuit SN 16, plate V-2). During the remainder of the cycle, the division rate of this divider is equal to 10.

Similarly, the second divider by 10 or 11 divides Q times by 11 during each count cycle, where Q is the value of the 10^1 Hz digit programmed in positive logic on the binary module comparator SN17.

The divider by 100 to 109 is directly programmed in positive logic by the value R of the 10^2 Hz digit, its division rate being at all times equal to (100+R). The division rate N of programmable counter DP1 can thus be expressed as a function of P, Q and R as follows :

$$N = 10 \left[11Q + 10 (100 + R - Q) - P \right] + 11P$$

P, Q, R : 0 to 9

For example, if the programmed frequency is of the form --- 573 Hz, the front divider divides 3 times by 11 and 1054 times by 10. The second divider by 10 or 11 divides 7 times by 11 and 98 times by 10, while the divider by 100 to 109 continuously divides by 105. The division rate N is thus equal to 10573.

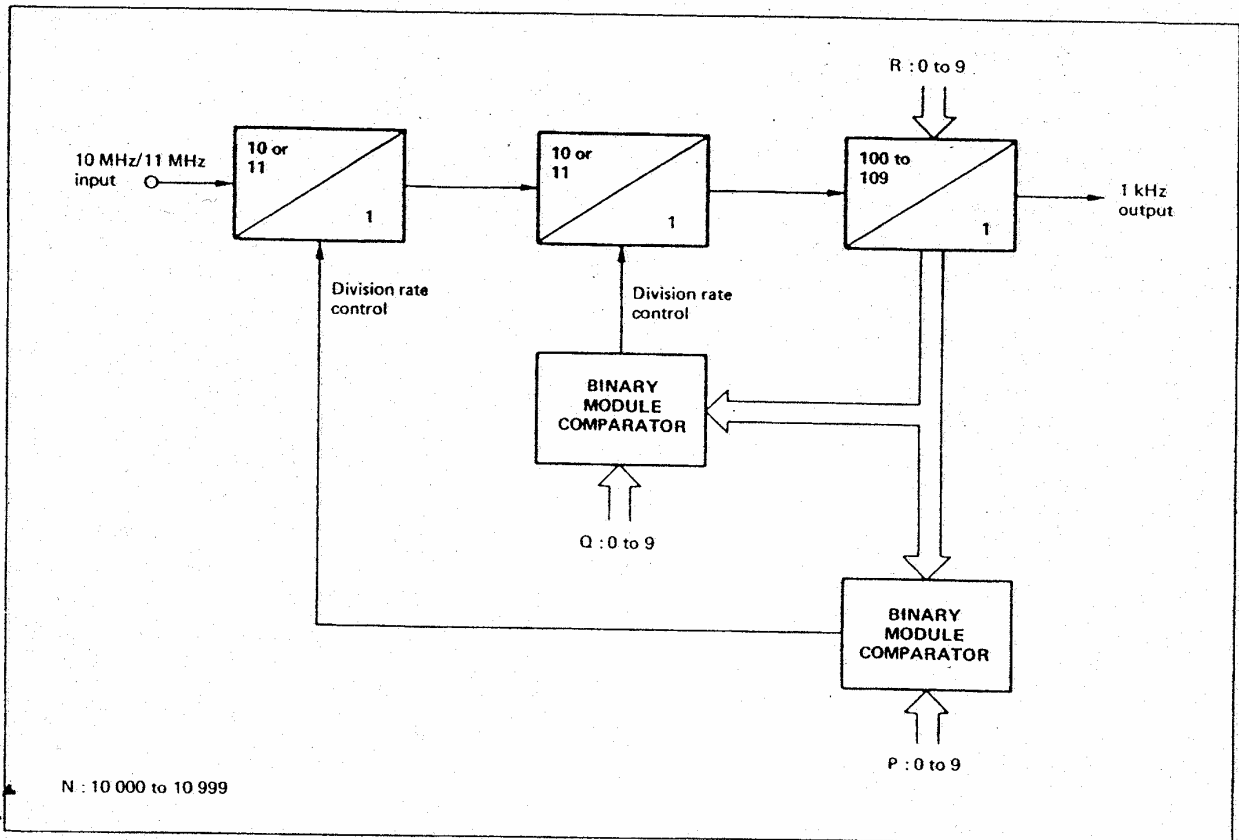

Figure V-2 PRINCIPLE OF COUNTER DP1

The front divider consists of a divider by 4 (integrated circuit SN11, plate V-2) preceded with a divider by 2 or 3 (integrated circuit SN10) whose division rate is controlled by two NAND gates (integrated circuit SN14). Depending on whether the whole must divide by 10 or 11, the sequence of division rates will be either 2 + 3 + 2 + 3 or 3 + 3 + 2 + 3.

The second divider by 10 or 11 is made up of integrated circuits SN12, SN13 and SN15, and operates on the same principle.

The divider by 100 to 109 consists of a BCD counter (integrated circuit SN18) followed by a binary counter (integrated circuit SN19). Inputs D8-D4-D2-D1 of the binary counter are continuously at state 1010, whereas those of the BCD counter receive the programming signals for the 10^2 Hz digit, which produces a division rate equal to $(100 + R)$.

PHASE COMPARATOR PRINCIPLE

The operation of the phase comparator rests up on the generation of a sawtooth which is interrupted by a sampling pulse, as shown in figure V-3.

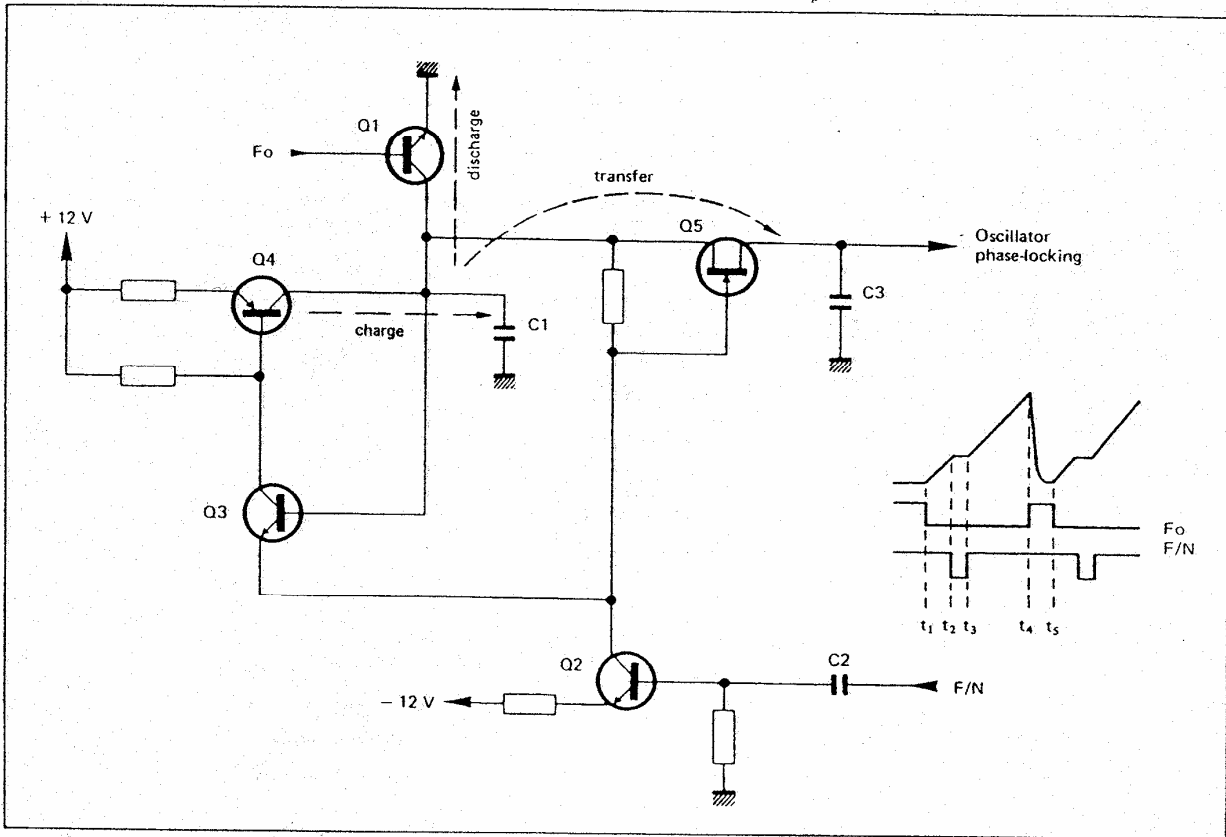

Figure V-3 PRINCIPLE OF PHASE COMPARATOR

At time t_1 , the negative edge of the reference F_0 cuts off transistor Q1, which starts the sawtooth by enabling capacitor C1 to charge at constant current.

At time t_2 , the sawtooth is interrupted by the negative edge of the signal F/N from the programmable counter, which cuts off transistors Q2, Q3 and Q4. At the same time, field-effect transistor Q5 starts to conduct and transfers the charge from capacitor C1 to storage capacitor C3.

At time t_3 , field-effect transistor Q5 is again cut off, whereas transistors Q2, Q3 and Q4 begin to conduct again, which restarts the sawtooth.

At time t_4 , the positive edge of the reference signal F_0 saturates transistor Q1 which therefore discharges capacitor C1. Another sawtooth begins at time t_5 on the negative edge of signal F_0 .

Any relative phase shift affecting signals F_0 and F/N shifts the time interval ($t_3 - t_2$) towards time t_1 or time t_4 . This displacement modifies the DC voltage stored in capacitor C3, which enables the frequency of the controlled oscillator to be corrected.

V-3 GENERATION 10^3 Hz - 10^4 Hz - 10^5 Hz

Refer to block diagram in plate V-1 and figure V-4, and schematic in plate V-3.

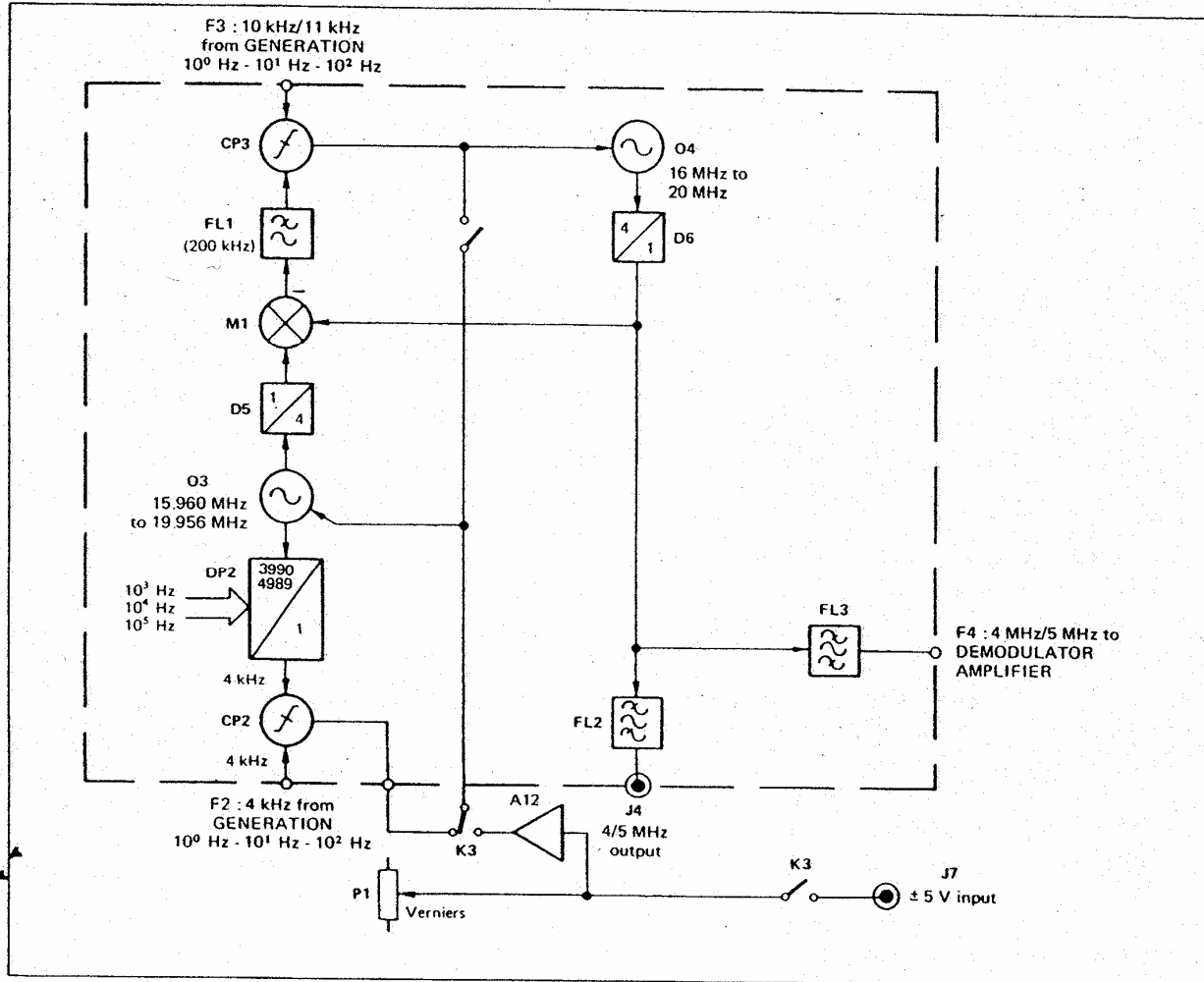

Figure V-4 GENERATION 10^3 Hz - 10^4 Hz - 10^5 Hz

This subassembly generates the 10^3 Hz, 10^4 Hz and 10^5 Hz increments of the output frequency while incorporating the 10^0 Hz, 10^1 Hz and 10^2 Hz increments carried by frequency F3 : 10 kHz/10.999kHz obtained at the output of the previously described subassembly.

The 10^3 Hz, 10^4 Hz and 10^5 Hz increments are generated by means of a phase-locked loop comprising oscillator O3, programmable counter DP2 and phase/frequency comparator CP2. Oscillator O3 delivers a frequency between 15.960 MHz and 19.956 MHz, that is divided by N : 3990 to 4989 in programmable counter DP2. The output frequency of counter DP2 is then compared in phase/frequency comparator CP2 with the reference frequency F2 : 4 kHz coming from Generation 10^0 Hz - 10^1 Hz - 10^2 Hz. In Synthesizer mode, comparator CP2 thus provides a DC voltage locking oscillator O3 onto a frequency equal to N times the reference frequency F2 : 4 kHz. In Generator or Sweeper mode, this control voltage is replaced by the output voltage of amplifier A12 (Control Circuits, plate V-7) providing for gradual variation of the output frequency of oscillator O3.

The combination of the 10^0 Hz, 10^1 Hz and 10^2 Hz increments carried by frequency F3 and the 10^3 Hz, 10^4 Hz and 10^5 Hz increments generated by oscillator O3 is effected by means of a second phase-locked loop comprising oscillator O4, divider D6, mixer M1, filter FL1 and phase/frequency comparator CP3.

Oscillator O4 delivers a frequency variable from 16 MHz to 20 MHz, that divider D6 divides by 4 in order to provide a 4 MHz to 5 MHz frequency. Mixer M1, made of an exclusive OR gate, beats this frequency with a 3.990MHz to 4.989MHz signal obtained by dividing the output frequency of oscillator O3 by 4 in divider D5.

Low-pass filter FL1 selects the difference frequency, and outputs a signal at a frequency variable between 10 kHz and 10.999 kHz, which is then compared in phase/frequency comparator CP3 with frequency F3 : 10 kHz/10.999 kHz coming from the Generation 10^0 Hz - 10^1 Hz - 10^2 Hz subassembly. Comparator CP3 therefore supplies a DC voltage which locks oscillator O4 onto a frequency comprising the 10^0 Hz to 10^2 Hz increments and also the 10^3 Hz to 10^5 Hz increments. In order to prevent oscillator O4 from locking onto a frequency below that generated by oscillator O3, mixer M1 and low-pass filter FL1 provide a signal in phase quadrature with the frequency to be compared. This signal is applied to the J input of one of the flip-flops of comparator CP3, and disables the phase comparison if the output frequency of divider D6 is less than that of divider D5.

The output signal of divider D6 is converted to a sinusoidal signal by band-pass filters FL2 and FL3, which respectively deliver frequency F4 : 4 MHz/5 MHz to connector (J4) on the rear panel of the instrument and to the Demodulator Amplifier subassembly.

During frequency changes involving the 10^3 Hz, 10^4 Hz or 10^5 Hz increments, an electronic switch consisting of transistors Q12 and Q13 (plate V-3) replaces the control voltage from comparator CP3 with an approach voltage obtained from comparator CP2 (Synthesizer mode) or from amplifier A12 (Generator or Sweeper mode). This substitution is intended to bring the output frequency of oscillator O4 close to its final value and is carried out when the difference between the control voltage and the approach voltage exceeds 0.6 volts.

PRINCIPLE OF PROGRAMMABLE COUNTER DP2

Programmable counter DP2 basically comprises two dividers by 10 or 11, a divider by 39 to 49, two BCD adders and two binary module comparators controlling respective dividers by 10 or 11.

During a count cycle, the front divider divides P times by 11, where P is the value of the 10^3 Hz digit programmed in positive logic on the corresponding binary module comparator (integrated circuit SN7, plate V-3). During the remainder of the cycle, the division rate of this divider is equal to 10.

The second divider by 10 or 11 divides Q times by 11 during each count cycle, where Q is the value of the 10^4 Hz digit shifted by 9. This shift is carried out by means of a BCD adder (integrated circuit SN11) whose inputs B8 - B4 - B2 - B1 are set to state 1001, while the inputs A8 - A4 - A2 - A1 receive the BCD programming signals of the 10^4 Hz digit.

For example, if the 10^4 Hz digit is 3, the BCD adder carries out the operation $9 + 3 = 12$, and the binary module comparator SN8 receives the digit $Q = 2$, which gives a division rate of 11 twice per cycle.

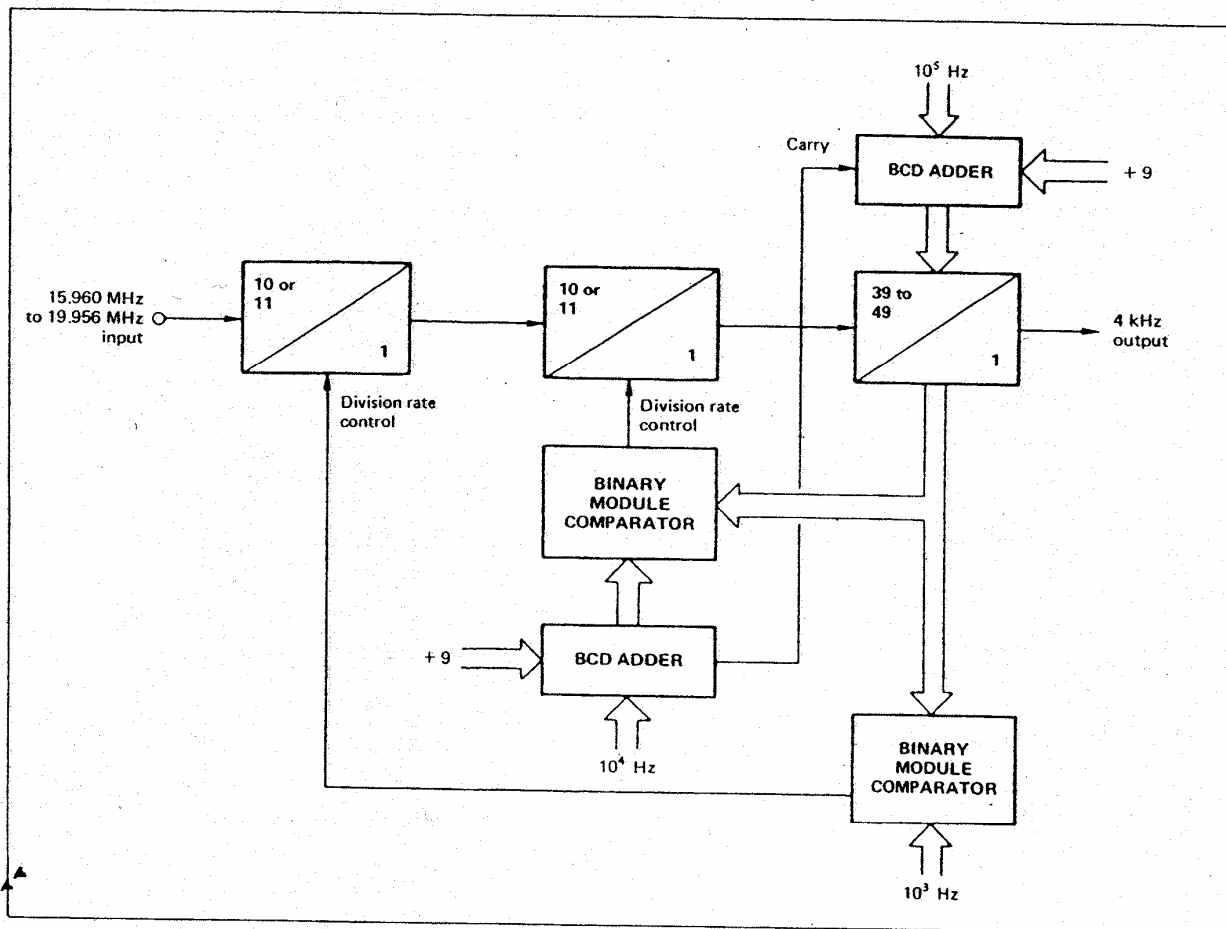

Figure V-5 PRINCIPLE OF COUNTER DP2

The divider by 39 to 49 is directly programmed in positive logic by the value R of the 10^5 Hz digit shifted by 9 or 10. As before, this shift is effected by means of a BCD adder (integrated circuit SN12) whose inputs B8 - B4 - B2 - B1 are set to state 1001. The input C_{in} receives the carry from adder SN11, and inputs A8 - A4 - A2 - A1 receive the programming signals of the 10^5 Hz digit. For example, if the 10^5 Hz and 10^4 Hz digits are respectively 5 and 3, the BCD adder achieves the operation $9 + 5 + \text{carry} = 15$, and the counter by 39 to 49 receives the digit $R = 5$, which gives a division rate of $39 + R = 44$.

The front divider consists of a divider by 4 (integrated circuit SN5) preceded with a divider by 2 or 3, the division rate of which is controlled by two NAND gates (integrated circuit SN5). Depending on whether the whole is to divide by 10 or 11, the sequence of division rates will be $2 + 3 + 2 + 3$ or $3 + 3 + 2 + 3$. The second divider by 10 or 11 comprises integrated circuits SN3, SN4 and SN6, and operates on the same principle.

The divider by 39 to 49 consists of a BCD counter (integrated circuit SN9) followed by a binary counter (integrated circuit SN10), whose inputs D8 - D4 - D2 - D1 receive the programming signals from adder SN12.

PRINCIPLE OF PHASE/FREQUENCY COMPARATOR

The operating principle of the phase/frequency comparator consists in generating pulses with a width proportional to the relative phase of the two compared signals, then in integrating these pulses so as to obtain a DC voltage permitting the phase-locking of an oscillator.

When the compared frequencies F_o and F_x are identical, the phase/frequency comparator acts as a phase comparator. When these two frequencies are unequal, the phase/frequency comparator indicates which one is larger, whence its appellation "phase/frequency comparator".

As shown in figure V-6, the digital section of the comparator consists of two J-K flip-flops whose outputs Q_1 and Q_2 are connected to an AND gate controlling the Reset input of each flip-flop.

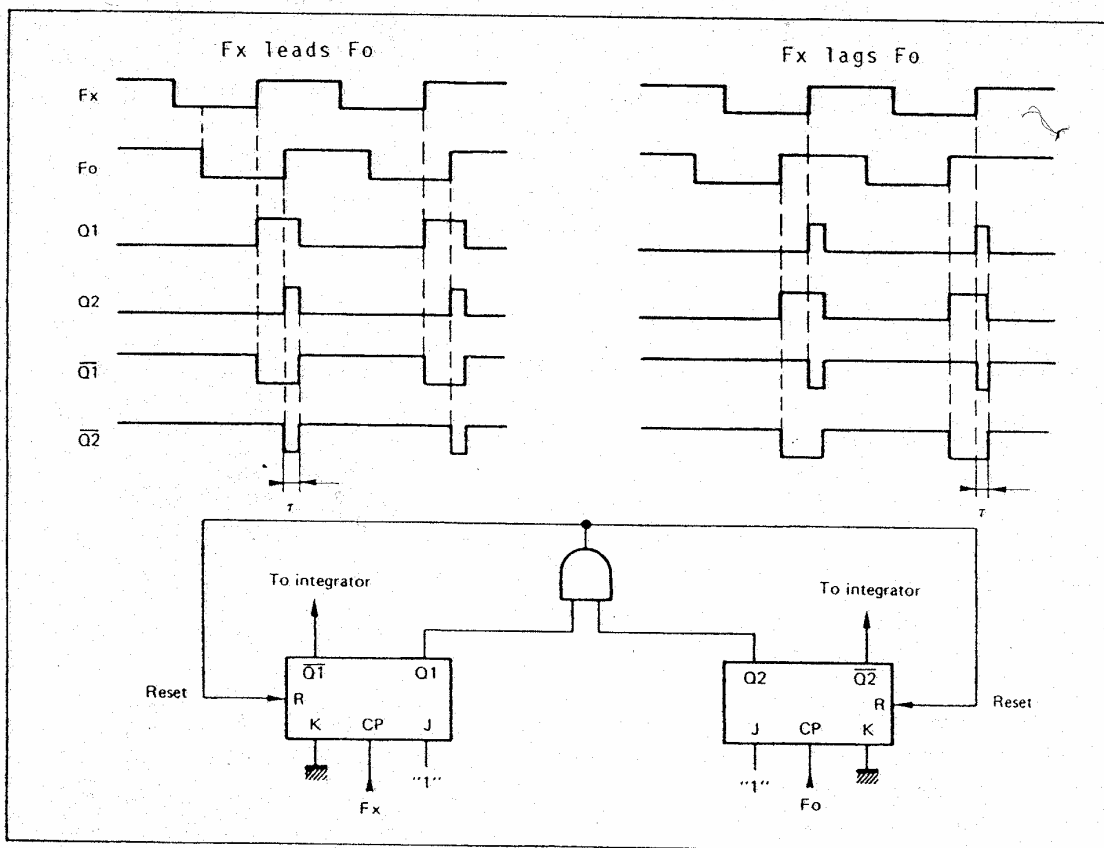

Figure V-6 PRINCIPLE OF PHASE/FREQUENCY COMPARATOR

The signals F_o and F_x to be compared are applied to the CP inputs of respective flip-flops. The K inputs are grounded and the J inputs receive a logic "1", so that the positive edges of the signals F_o and F_x cause a logic "1" to appear at the Q output of the corresponding flip-flop. Due to the reaction of the AND gate upon the Reset inputs, outputs Q_1 and Q_2 return to state "0" after they have both reached state "1", with a brief delay equal to the propagation time through the AND gate.

The difference between the widths of the pulses at outputs Q_1 and Q_2 is therefore proportional to the relative phase of the signals F_o and F_x . A DC voltage proportional to this relative phase is therefore obtained by integrating the output pulses by means of a differential integrator.

V-4 DEMODULATOR - AMPLIFIER

Refer to block diagram in plate V-1 and figure V-7, and schematic in plate V-4.

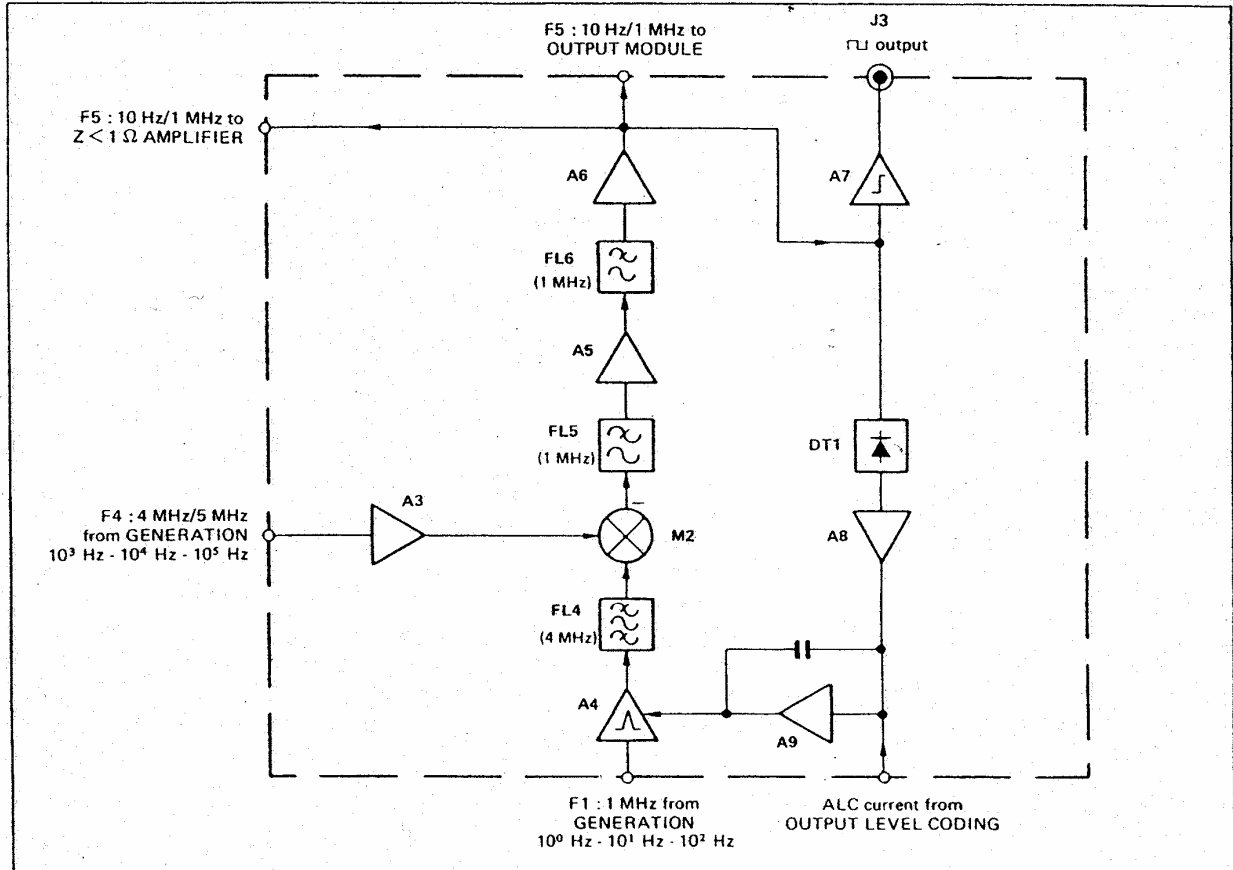

Figure V-7 DEMODULATOR - AMPLIFIER

The Demodulator Amplifier subassembly converts frequency F4, which is variable from 4 MHz to 5 MHz in steps of 1 Hz, to output frequency F5 : 10 Hz/1MHz and provides regulation of the output level.

Mixer M2 and low-pass filter FL5 carry out a subtractive mixing of frequency F4 : 4 MHz/ 5 MHz coming from buffer A3 with a 4 MHz signal obtained by multiplying by 4 frequency F1 : 1 MHz issued from the Generation 10^0 Hz - 10^1 Hz - 10^3 Hz subassembly, this frequency multiplication being carried out by harmonic generator A4 and band-pass filter FL4. Frequency F5 : 10 Hz/1MHz obtained at the output of low-pass filter FL5 is amplified by amplifier A5, filtered through low-pass filter FL6 and again amplified by amplifier A6, providing an output signal between 550 mVrms and 5.5 Vrms, depending on the level set on switches (K4). The output signal of amplifier A6 is routed to the Output Module, to Z < 1 Ω Amplifier, and to shaper A7 providing square-wave signals at an amplitude of 5 V or 10 V to connector (J3).

The level of the signal at the output of amplifier A6 is detected by means of a full-wave detector DT1 whose outputs are connected to differential amplifier A8. This provides an ALC current which, following integration in amplifier A9, regulates the level of the 4 MHz signal applied to mixer M2 and consequently the level of the output signal. In addition to the ALC current from amplifier A8, integrator A9 receives a current proportional to the 1 dB, 0.1dB and 0.01dB increments of the output level from the Output Level Coding subassembly.

The ALC time constant is controlled by the parallel connection of a $10\ \mu\text{F}$ capacitor with the integrating capacitor of amplifier A9, which has a value of $0.1\ \mu\text{F}$. The parallel connection of the $10\ \mu\text{F}$ capacitor provides a long ALC time constant enabling the output level to be regulated over the entire frequency range. On the other hand, the switching out of circuit of this capacitor provides for rapid switching of frequencies above 10 kHz.

The output level inhibition is obtained by cutting off transistor Q1, which disables integrator A9 and removes the 4 MHz signal from mixer M2.

V-5 OUTPUT LEVEL CODING

Refer to block diagram in plate V-1 and figure V-8, and schematic in plate V-5.

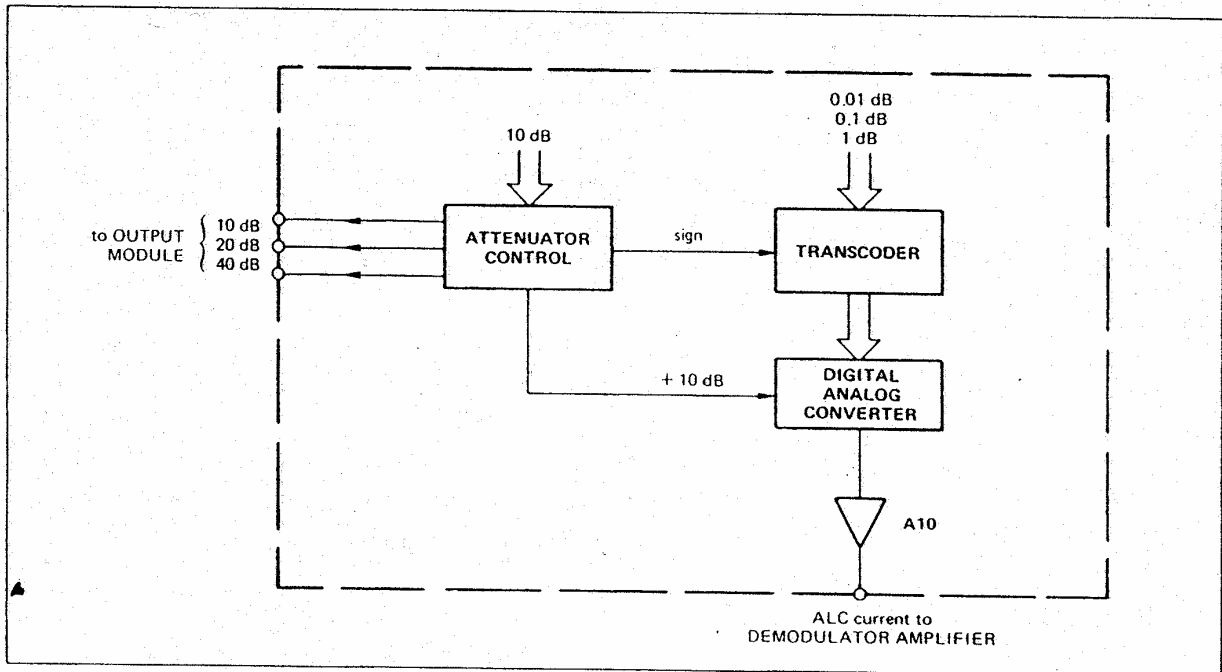

Figure V-8 OUTPUT LEVEL CODING

The Output Level Coding subassembly comprises attenuator control circuitry and a digital/analog converter which outputs a current proportional to the 1 dB, 0.1 dB and 0.01 dB increments of the output level.

The attenuator is controlled by means of a BCD/decimal decoder (integrated circuit SN1) and OR gates (integrated circuits SN2 and SN3) which switch the attenuating cells as a function of the output level 10 dB steps, as shown in the table of figure V-9. The signal obtained at output 0 of the BCD/decimal decoder is also sent to the digital/analog converter so as to increase by 10 dB the ALC current sent to the Demodulator Amplifier when the output level is between + 10 dBm + 20 dBm.

Setting of 10 dB steps	+ 10 dB ALC current	10 dB cell	20 dB cell	40 dB cell
+ 1	1	0	0	0
+ 0	0	0	0	0
- 0	0	1	0	0
- 1	0	0	1	0
- 2	0	1	1	0
- 3	0	0	0	1
- 4	0	1	0	1
- 5	0	0	1	1
- 6	0	1	1	1

Figure V-9 CODING OF 10-dB STEPS

The digital/analog converter comprises an operational amplifier (integrated circuit SN5) whose non-inverting input is connected to a resistor network switched by C-MOS switches (integrated circuits SN9 to SN13). The switching operation is controlled by a code converter consisting of three type 4561 integrated circuits providing a positive or negative count of the value of the 1 dB, 0.1 dB and 0.01 dB increments of the output level. In local mode between + 0 dBm and + 19.99 dBm, this value is counted in the positive sense, the type 4561 integrated circuits providing the 9's complement of the input signals. In local mode between - 0 dBm and - 69.99 dBm, and in Remote programming mode, the type 4561 integrated circuits are transparent and the value of the 1 dB, 0.1 dB and 0.01 dB steps is counted negatively.

Depending on the state of the 0 output of the BCD/decimal decoder SN1, the analog signal obtained from operational amplifier SN5 is transmitted directly to follower amplifier A10, or is first attenuated by 10 dB by means of resistors R20 and R21. In both cases, follower amplifier A10 supplies to the Demodulator Amplifier a current which is proportional to the level of the signal at the output of amplifier A6.

V-6 OUTPUT MODULE

Refer to block diagram in plate V-1 and figure V-10, and schematic in plate V-6.

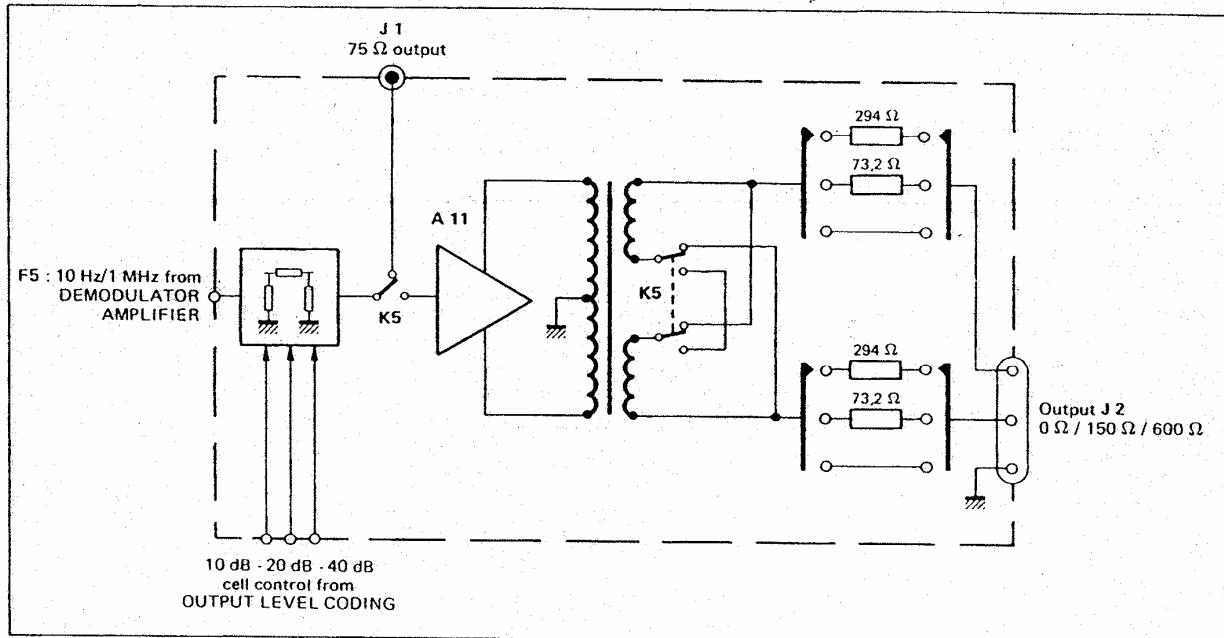

Figure V-10 OUTPUT MODULE

This module includes the output attenuator and the impedance converter circuit which enables the output signal of the synthesizer to be supplied at four different impedances.

The output attenuator includes three Π cells with $75\ \Omega$ characteristic impedance providing respectively 10 dB, 20 dB and 40 dB attenuation. Each of these cells is controlled by means of a -12 V voltage issued from the Output Level Coding subassembly.

The impedance converter circuit consists of symmetrical amplifier A11, a transformer with four windings, and impedance selection keyboard (K5). In order to avoid all risk of the transformer core saturating, amplifier A11 has an automatic DC current centering circuit consisting of operational amplifier SN2.

When an impedance of $75\ \Omega$ is selected on keyboard (K5), the signal provided by the output attenuator is applied directly to connector (J1). For all other impedances, this signal is routed to amplifier A11 and the impedance converter before being applied to connector (J2).

When the "150 Ω " key of keyboard (K5) is pressed, the two secondary windings of the transformer are connected in parallel and two $73.2\ \Omega$ resistors are connected to the output. These resistors are short-circuited if the "0" key is also pressed. When the "600 Ω " key is pressed, the two secondary windings are connected in series and two resistors of $294\ \Omega$ are connected to the output, these resistors being short-circuited if the "0" key is also pressed.

V-7 $Z < 1 \Omega$ AMPLIFIER

Refer to schematic in plate V-9.

This subassembly comprises an amplifier using complementary transistors which receives frequency $F_5 : 10 \text{ Hz}/1 \text{ MHz}$ from the Demodulator Amplifier. It provides a signal with $0 \text{ dBm}/75 \Omega$ to $+ 20 \text{ dBm}/75 \Omega$ electromotive force, depending on the level of the main output signal, at an impedance of less than 1Ω .

V-8 PARALLEL BCD PROGRAMMING (OPTION 010)

Refer to schematic in plate V-12.

This option enables the logic signals from the manual controls of the synthesizer to be replaced by external parallel BCD signals applied to programming connectors (S03) and (S04).

V-9 IEEE BUS PROGRAMMING (OPTION 020)

Refer to block diagram in figure V-11, and schematics in plates V-10 and V-11.

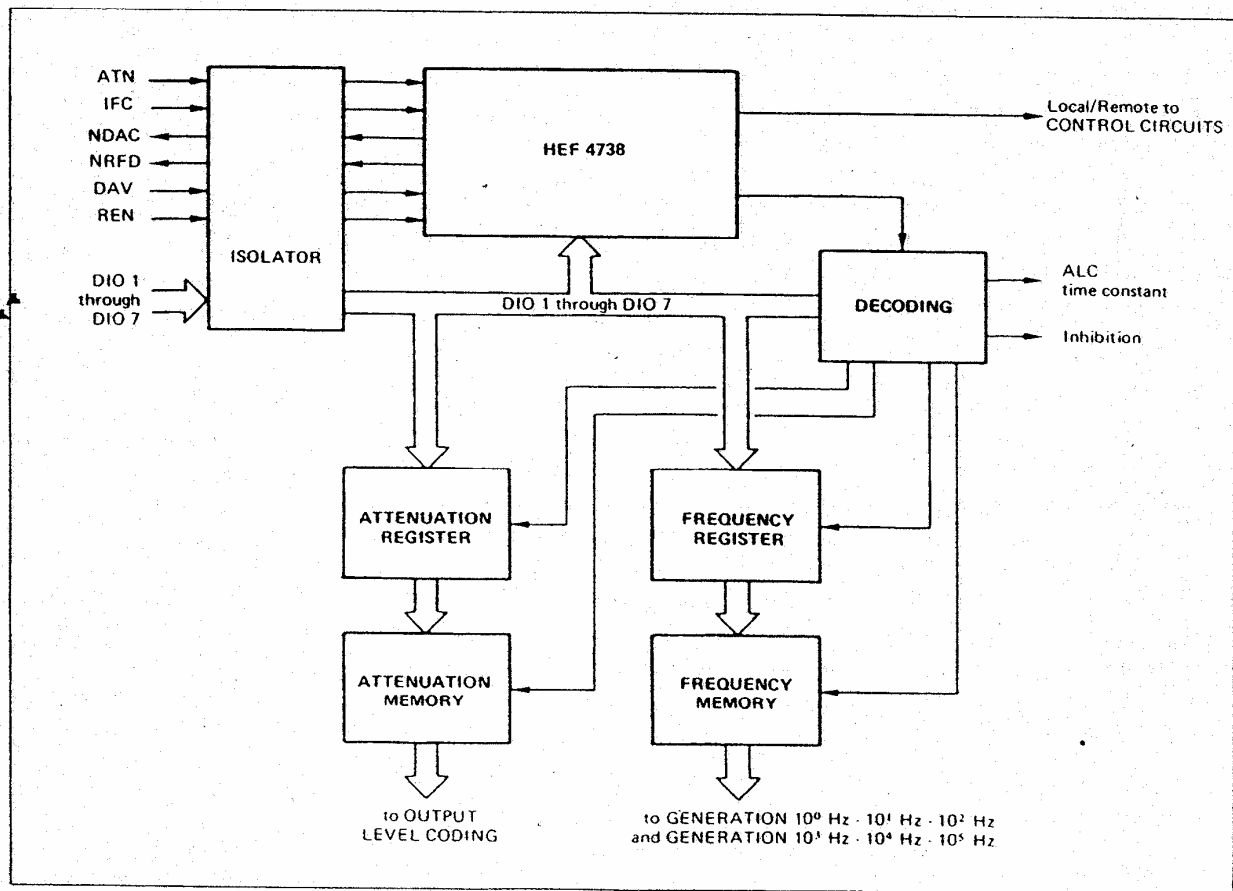

Figure V-11 IEEE BUS PROGRAMMING

This option, consisting of two subassemblies, converts the data supplied by the IEEE Bus into parallel BCD signals which are substituted in Programming mode for the logic signals from the manual synthesizer controls.

V-9-1 IEEE BUS ISOLATOR

This circuit comprises a series of Schmitt triggers (integrated circuits SN1 and SN2, plate V-10), followed by galvanic isolators (transformers T1, T2 and T3) which enable the ground of the IEEE bus to be isolated from that of the synthesizer. For this reason, the various circuits upstream of the galvanic isolators are supplied by a +5 V floating voltage issued from the IEEE Bus Registers subassembly.

The secondary winding of each transformer is connected in a feedback to a C-MOS gate (integrated circuits SN5, SN6 and SN7) which stores the transient pulse induced in the winding.

V-9-2 IEEE BUS REGISTERS

This circuit converts the data transmitted by the IEEE Bus Isolator subassembly into parallel BCD signals.

The handshake process with the IEEE bus is entirely controlled by the HEF 4738 integrated circuit, with the aid of a 4014 shift-register. These two integrated circuits provide for the recognition of the address selected by switches (K10), for the Local/Remote control of the synthesizer, and for the control of the Decoding circuit. The HEF 4738 integrated circuit is controlled by a 2 MHz square-wave signal obtained by dividing by 2 the frequency generated by a 4 MHz oscillator (integrated circuit SN30).

The digits and the characters CR, A, ?, F, < and > are decoded by four decoders (integrated circuits SN4 and SN5, plate V-11) followed by NOR gates (integrated circuits SN6 to SN9) and JK flip-flops (integrated circuits SN10, SN11 and SN12). The decoding circuit also controls transfer of data from lines DI01 to DI04 to the output registers, and supplies the Demodulator-Amplifier with the Inhibition and the ALC time constant programming signals.

The output level attenuation transmitted on lines DI01 to DI04 is transferred to the Attenuation Register consisting of 4 shift registers (integrated circuits SN14 and SN15) and to the Attenuation Memory consisting of 16 type D flip-flops (integrated circuits SN20 to SN23), which supplies this attenuation in parallel BCD code to the Output Level Coding subassembly.

The output frequency transmitted on lines DI01 to DI04 is transferred to the Frequency Register consisting of 8 shift registers (integrated circuits SN16 to SN19) and to the Frequency Memory consisting of 24 type D flip-flops (integrated circuits SN24 to SN29), which supplies this frequency in parallel BCD code to the Generation 10^0 Hz - 10^1 Hz - 10^2 Hz and Generation 10^3 Hz - 10^4 Hz - 10^5 Hz subassemblies.

CHAPTER VI
MAINTENANCE

The tests described in the following pages are designed to enable the user to check that the instrument conforms to the technical characteristics set out in chapter II. These tests may be carried out as acceptance tests, as periodic performance checks, or as a control on the instrument characteristics following repairs.

INSTRUMENTS REQUIRED FOR EXECUTING TESTS

TYPE OF INSTRUMENT	REFERENCE	CHARACTERISTICS
Alternostat		0 V to 260 V ; 200 W
Multimeter	FLUKE 8000 A	DC/AC ; accuracy $\pm 1\%$
Oscilloscope	H.P. 180C + 1808A + 1820C	75 MHz bandwidth
Frequencymeter	SCHLUMBERGER FH 2523	10 Hz to 500 MHz ; 9 digits
RF voltmeter	H.P. 3400 A	10 Hz to 10 MHz ; accuracy $\pm 1\%$
Milliwattmeter	WANDEL & GOLTERMANN EPM-1	10 kHz to 300 MHz ; accuracy ± 0.015 dB
Standard attenuator	SIEMENS D 2054	0 dB to 99.9 dB
Decibelmeter	ADRET 6101B + 6303B + 63032A + 63030B	DC to 11 MHz ; resolution 0.01 dB
Spectrum analyser	ADRET 6100B + 6303B + 6503A + 63032A	DC to 11 MHz ; dynamic range 120 dB
X-Y recorder	H.P. 7041A	Speed 76 cm/s
ECF 136	ADRET	Impedance transformer 75 Ω /150 Ω /600 Ω
ECF 141	ADRET	Asymmetry detector
Frequency difference multiplier	ADRET 4110A	Resolution 10^{-8} to 10^{-12}
Frequency standard	ADRET 3310A	300 Hz to 60 MHz ; stability $\pm 5 \cdot 10^{-9}/24$ h
DC source	ADRET 102	Accuracy $\pm 5 \cdot 10^{-5}$; output current 50 mA

N° d'ESSAI TEST NUMBER	CONDITIONS	SANCTIONS RESULTS
<p>1</p> <p>2</p> <p>45 Hz to 450 Hz 115V - 230V power supply Alternostat Multimeter</p>	<p>VISUAL CHECK</p> <p>Check the external appearance of the instrument and that protective fuse (F1) is of the correct rating. (300 mA for 115V supply, 150 mA for 230 V supply).</p> <p>MAINS SUPPLY REGULATION</p> <p>Connect the instrument to a 45 Hz/450 Hz power supply through an alternostat, as shown in figure VI-1.</p> <div data-bbox="466 667 1023 864" data-label="Diagram"> </div> <p>Figure VI-1 MAINS SUPPLY REGULATION</p> <p>a) Vary the supply frequency between 45 Hz and 450 Hz for supply voltages of 115V and 230V.</p> <p>Measure the voltages present at connector (S01) of the rear panel :</p> <ul style="list-style-type: none"> + 12V relative to ground. - 12V relative to ground. + 6V relative to ground. <div data-bbox="518 1205 957 1451" data-label="Diagram"> </div> <p>Figure VI-2 CONNECTOR (S01)</p> <p>b) Repeat the above test using the alternostat to apply voltages of 115V ± 10% and 230V ± 10%.</p> <p>c) Use the multimeter to measure the current drawn by the instrument at both mains supply voltages. Calculate the apparent power consumption by means of the formula $P = UI$.</p>	<p>Accuracy :</p> <ul style="list-style-type: none"> + 11.8 V to + 12.5 V - 11.8 V to - 12.5 V + 5.75 V to + 6.25 V <p>The previously measured voltages must remain substantially identical.</p> <p>$P < 20 \text{ VA}$</p>

N° d'ESSAI TEST NUMBER	CONDITIONS	SANCTIONS RESULTS												
<p>3</p> <p>Power supply Alternostat 250 Hz low-pass filter Oscilloscope</p>	<p>RESIDUAL LF RIPPLE</p> <p>With the instrument supplied at 50 Hz, use the 250 Hz low-pass filter and the oscilloscope to measure the LF ripple on the +12V, +6V and -12V voltages available at connector (S01).</p>	<p>Residual ripple < 5 mVp-p</p>												
<p>4</p> <p>Frequencymeter DC source</p>	<p>OUTPUT FREQUENCY</p> <p>a) Synthesizer mode :</p> <p>With the frequencymeter and the 2230A synthesizer connected to the same 5 MHz reference frequency, use the frequencymeter to check that the frequency at connector (J1) is the same as that set on switches (K2).</p> <p>b) Generator mode :</p> <p>Set a frequency of 500 000 Hz on switches (K2), set potentiometer (P1) to the 0.5 mark, and adjust the vernier of this potentiometer so as to obtain very slow flashing of indicator lights (DS3). Then measure the output frequency at various positions of potentiometer (P1), the vernier being left in its initial position. The maximum permissible error relative to the frequency indicated on the graduated dial is ± 50 kHz in all circumstances.</p> <p>If the error is greater than 50 kHz, the amplifier A12 of subassembly 02 7003 (Control Circuits, plate V-7) must be recalibrated as follows :</p> <ul style="list-style-type: none"> - Set a frequency of 500 000 Hz on switches (K2), release the three keys of keyboard (K3), and set potentiometer P1 of subassembly 02 7003 so as to obtain very slow flashing of indicator lights (DS3). - Depress the "GENER", key of keyboard (K3), set potentiometer (P1) to 0.5, and adjust the vernier of this potentiometer so as to obtain a very slow flashing of indicator lights (DS3). Then set potentiometer (P1) to 0.1 and adjust potentiometer P2 of subassembly 02 7003 to obtain an output frequency of 100 kHz. <p>Then check the value of the output frequency when potentiometer (P1) is set to 1.</p>	<table border="1" data-bbox="1054 1032 1294 1245"> <thead> <tr> <th>(P1)</th> <th>Output frequency</th> </tr> </thead> <tbody> <tr> <td>0.1</td> <td>100 \pm 50 kHz</td> </tr> <tr> <td>0.3</td> <td>300 \pm 50 kHz</td> </tr> <tr> <td>0.5</td> <td>500 kHz</td> </tr> <tr> <td>0.7</td> <td>700 \pm 50 kHz</td> </tr> <tr> <td>0.9</td> <td>900 \pm 50 kHz</td> </tr> </tbody> </table> <p>Output frequency : 1 MHz \pm 50 kHz</p>	(P1)	Output frequency	0.1	100 \pm 50 kHz	0.3	300 \pm 50 kHz	0.5	500 kHz	0.7	700 \pm 50 kHz	0.9	900 \pm 50 kHz
(P1)	Output frequency													
0.1	100 \pm 50 kHz													
0.3	300 \pm 50 kHz													
0.5	500 kHz													
0.7	700 \pm 50 kHz													
0.9	900 \pm 50 kHz													

N° d'ESSAI TEST NUMBER	CONDITIONS	SANCTIONS RESULTS
<p>5</p> <p>Milliwattmeter Standard attenuator Decibelmeter ECF 136</p>	<p>c) Sweeper mode :</p> <p>Set a frequency of 500 000 Hz on switches (K2), set potentiometer (P1) to 0.5, and adjust the vernier of the potentiometer so as to obtain very slow flashing of indicator lights (DS3).</p> <p>Apply -5V to connector (J7) and use the frequency meter to check that the output frequency is less than 100 kHz. Then apply +5V to connector (J7) and check that the output frequency is between 900 kHz and 1.1 MHz.</p> <p>OUTPUT LEVEL</p> <p>a) In Synthesizer mode, set a frequency of 10 kHz on switches (K2) and select an output impedance of 75 Ω by means of keyboard (K5). Using the milliwattmeter, measure the output level at connector (J1) when -0.00 dBm and +0.00 dBm are set on switches (K4).</p> <p>If necessary, adjust the level at -0.00 dBm using potentiometer P1 and then the level at +0.00 dBm by means of potentiometer P2 of the Demodulator-Amplifier subassembly (plate V-4).</p> <p>b) In Synthesizer mode, set a frequency of 10 kHz on switches (K2) and select an impedance of 150 Ω on keyboard (K5).</p> <p>Set +3.01 dBm on switches (K4) and measure the output level with the milliwattmeter, matching the impedances by setting the ECF 136 to 150 Ω (insertion loss 3.01 dB).</p> <p>If necessary, adjust potentiometer P1 of the Output Module (plate V-6) for calibrating this level.</p> <p>c) In Synthesizer mode, set a frequency of 10 kHz on switches (K2) and select an impedance of 600 Ω on keyboard (K5).</p> <p>Set 9.03 dBm on switches (K4) and measure the output level using the milliwattmeter, matching the impedances by switching the ECF 136 to 600 Ω (insertion loss 9.03 dB).</p> <p>d) In Synthesizer mode, set a frequency of 10 kHz and an impedance of 75 Ω, and check the accuracy of the 0.01 dB and 0.1 dB steps of the output level using the milliwattmeter.</p>	<p>Linearity : $\pm 10\%$</p> <p>Accuracy at 0 dBm : ± 0.2 dB</p> <p>Measured level : 0 dBm ± 0.2 dB</p> <p>Measured level : 0 dBm ± 0.2 dB</p> <p>0.01 dB steps : ± 0.005 per step, max.error ± 0.01 dB.</p>

N° d'ESSAI TEST NUMBER	CONDITIONS	SANCTIONS RESULTS
<p>7</p> <p>RF voltmeter ECF 141</p>	<p>to $F < 10$ kHz and connect the milliwattmeter to output (J2), matching the impedances by switching the ECF 136 to 600 Ω (insertion loss 9.03 dB).</p> <p>Vary the synthesized frequency from 200 Hz to 300 kHz, and measure the output level variation.</p> <p>SIGNAL UNBALANCE</p> <p>a) 150 Ω impedance :</p> <p>Set + 6.00 dBm on switches (K4), set switch (K9) to $F < 10$ kHz and connect the ECF 141 (switched to 150 Ω) to connector (J2).</p> <p>Connect the output of the ECF 141 to the RF voltmeter and measure the signal level relative to 0 dBm/600 Ω while varying the synthesized frequency from 200 Hz to 620 kHz.</p> <p>b) 600 Ω impedance :</p> <p>Set + 0.00 dBm on switches (K4), set switch (K9) to $F < 10$ kHz and connect the ECF 141 (switched to 600 Ω) to connector (J2).</p> <p>Connect the output of the ECF 141 to the RF voltmeter and measure the signal level relative to 0 dBm/600 Ω while varying the synthesized frequency from 200 Hz to 110 kHz.</p>	<p>± 0.2 dB from 620 kHz to 1 MHz.</p> <p>Level flatness :</p> <p>± 0.05 dB from 200 Hz to 110 kHz.</p> <p>± 0.3 dB from 110 kHz to 300 kHz.</p> <p>Signal unbalance : - 50 dB</p> <p>Signal unbalance : - 50 dB</p>
<p>8</p> <p>Spectrum analyser X-Y recorder ECF 136</p>	<p>HARMONIC AND NONHARMONIC CONTENT</p> <p>a) 75 Ω impedance :</p> <p>Set + 10 dBm on switches (K4) and connect the spectrum analyser to output (J1), ensuring that the impedances are matched.</p> <p>Measure the relative levels of the harmonic and nonharmonic components at various frequencies between 50 Hz and 1 MHz, switch (K9) being set to $F < 10$ kHz for frequencies less than 10 kHz.</p> <p>b) 150 Ω impedance :</p> <p>Set + 10 dBm on switches (K4) and connect the spectrum analyser to output (J2), ensuring that the impedances are matched by switching the ECF 136 to 150 Ω (insertion loss 3.01 dB).</p> <p>Measure the relative levels of the harmonic and nonharmonic components at various frequencies</p>	<p>Harmonics at + 10 dBm :</p> <p>- 45 dB from 50 Hz to 300 Hz.</p> <p>- 55 dB from 300 Hz to 1 MHz.</p> <p>Nonharmonics : - 60 dB</p> <p>Harmonics at + 10 dBm : - 50 dB</p>

N° d'ESSAI TEST NUMBER	CONDITIONS	SANCTIONS RESULTS
	<p>between 200 Hz and 1 MHz, switch (K9) being set to F < 10 kHz for frequencies less than 10 kHz.</p> <p>c) 600 Ω impedance :</p> <p>Set + 10 dBm on switches (K4) and connect the spectrum analyser to output (J2), ensuring that the impedances are matched by switching the ECF 136 to 600 Ω (insertion loss 9.03 dB).</p> <p>Measure the relative levels of the harmonic and nonharmonic components at various frequencies between 200 Hz and 300 kHz, switch (K9) being set to F < 10 kHz for frequencies less than 10 kHz.</p>	<p>Nonharmonics :</p> <p>- 60 dB</p> <p>Harmonics at + 10 dBm :</p> <p>- 50 dB</p> <p>Nonharmonics : - 60 dB</p>
<p>9</p> <p>Spectrum analyser X-Y recorder ECF 136</p>	<p>PHASE-NOISE</p> <p>Set + 10 dBm on switches (K4), select a 75 Ω impedance on keyboard (K5), and connect the spectrum analyser to output (J1).</p> <p>With switch (K9) set to F < 10 kHz, measure the phase-noise at 100 Hz, 1 kHz, 10 kHz and 100 kHz from carrier at various output frequencies.</p> <p>These measurements may also be carried out at the 150 Ω or 600 Ω output, using the ECF 136 adaptor.</p>	<p>Phase-noise in a 1 Hz band :</p> <p>- 85 dB at 100 Hz - 95 dB at 1 kHz - 110 dB at 10 kHz - 120 dB at 100kHz</p>
<p>10</p> <p>Oscilloscope</p>	<p>SQUARE-WAVE OUTPUT</p> <p>Use the oscilloscope to measure the rise and fall times of the square-wave signals at connector (J3).</p>	<p>Rise time : 300 ns Fall time : 100 ns</p>
<p>11</p> <p>RF voltmeter Spectrum analyser X-Y recorder</p>	<p>TRACKING OUTPUT</p> <p>a) Output level : Use the RF voltmeter to measure the level of the tracking signal available at connector (J4).</p> <p>b) Nonharmonic content : Use the spectrum analyser to measure the relative levels of nonharmonic components of the tracking signal.</p>	<p>Level : + 6 dBm/75 Ω \pm 2 dB</p> <p>Nonharmonics : - 60 dB</p>
<p>12</p> <p>Milliwattmeter Spectrum analyser X-Y recorder</p>	<p>AUXILIARY OUTPUT Z < 1 Ω</p> <p>a) Output level : Set a frequency of 10 kHz on switches (K2) at a level of +0.00 dBm on switches (K4). Use the milliwattmeter to measure the level of the signal at connector (J8) for a 75 Ω load.</p>	<p>Level : 0 dBm/75 Ω</p>

N° d'ESSAI TEST NUMBER	CONDITIONS	SANCTIONS RESULTS
	<p>If necessary, adjust this level by means of potentiometer P2 of the $Z < 1 \Omega$ Amplifier subassembly (plate V-9).</p> <p>b) Output level flatness : Set + 0.00 dBm on switches (K4), set switch (K9) to $F < 10$ kHz, and connect the milliwattmeter to connector (J8). Vary the synthesized frequency from 50 Hz to 1 MHz and measure the output level variation relative to 0 dBm.</p> <p>c) Harmonic and nonharmonic content : Set + 10 dBm on switches (K4) and connect the spectrum analyser to output (J8). Measure the relative levels of the harmonic and nonharmonic components at various frequencies between 50 Hz and 1 MHz, with switch (K9) set to $F < 10$ kHz for frequencies less than 10 kHz.</p>	<p>Level flatness : ± 0.5 dB from 50 Hz to 200 Hz. ± 0.3 dB from 200 Hz to 1 MHz.</p> <p>Harmonics at + 10 dBm : - 40 dB from 50 Hz to 300 Hz. - 50 dB from 300 Hz to 1 MHz. Nonharmonics : - 60 dB</p>
13 RF voltmeter	<p>1 MHz REFERENCE OUTPUT</p> <p>Use the RF voltmeter to measure the level of the 1 MHz reference output at connector (J6) for a load of 50 Ω.</p>	<p>Level : 550 mVrms/50 $\Omega \pm 10$ %</p>
14 Frequency difference multiplier Frequency standard	<p>MASTER OSCILLATOR STABILITY</p> <p>Use the frequency difference multiplier to measure the relative difference $\Delta F/F$ between the 5 MHz frequency available at connector (J6) and the 5 MHz signal from the frequency standard.</p> <p>Leave the synthesizer switched on, and measure the difference $\Delta F'/F$ between the two frequencies 24 hours later.</p> <p>If necessary, recalibrate the internal Master Oscillator by means of capacitor C13 located on the Generation 10^0 Hz - 10^1 Hz - 10^2 Hz subassembly.</p>	<p>$\left \frac{\Delta F'}{F} - \frac{\Delta F}{F} \right < 3 \cdot 10^{-6}$</p> <p>after 24 hours of continuous operation.</p>
15 Oscilloscope Frequency standard	<p>EXTERNAL REFERENCE FREQUENCY</p> <p>Connect the 5 MHz reference frequency from the frequency standard to connector (J5) on the synthesizer and to channel 1 on the oscilloscope.</p> <p>Connect output (J6) of the synthesizer to channel 2 of the oscilloscope, and check that the two signals appearing on the screen are stationary relative to one another as the level of the 5 MHz reference frequency applied to connector (J5) is varied from 220 mVrms/50 Ω to 1 Vrms/50 Ω.</p>	

CHAPTER VII
PLATES, SCHEMATICS,
PARTS LIST

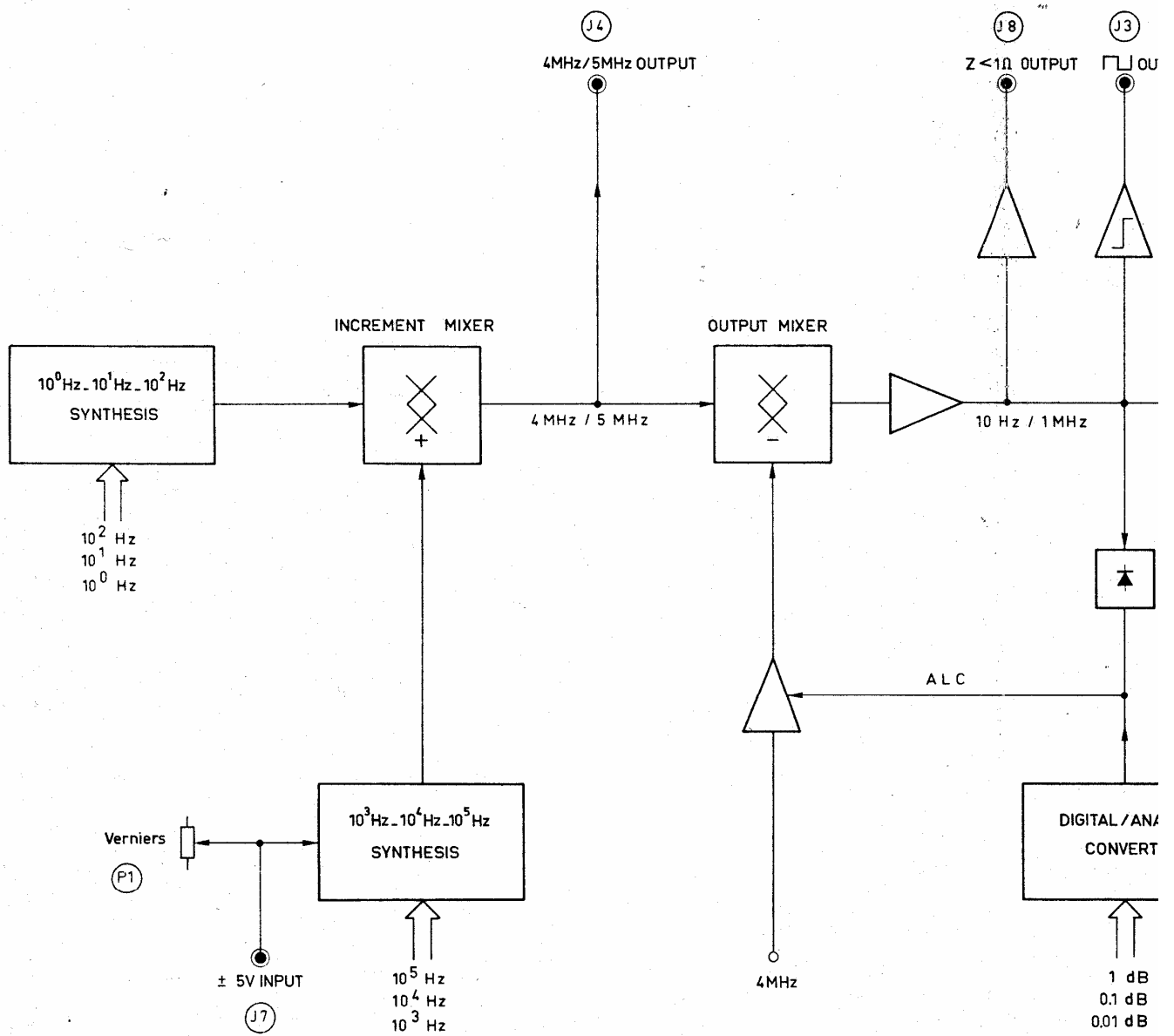

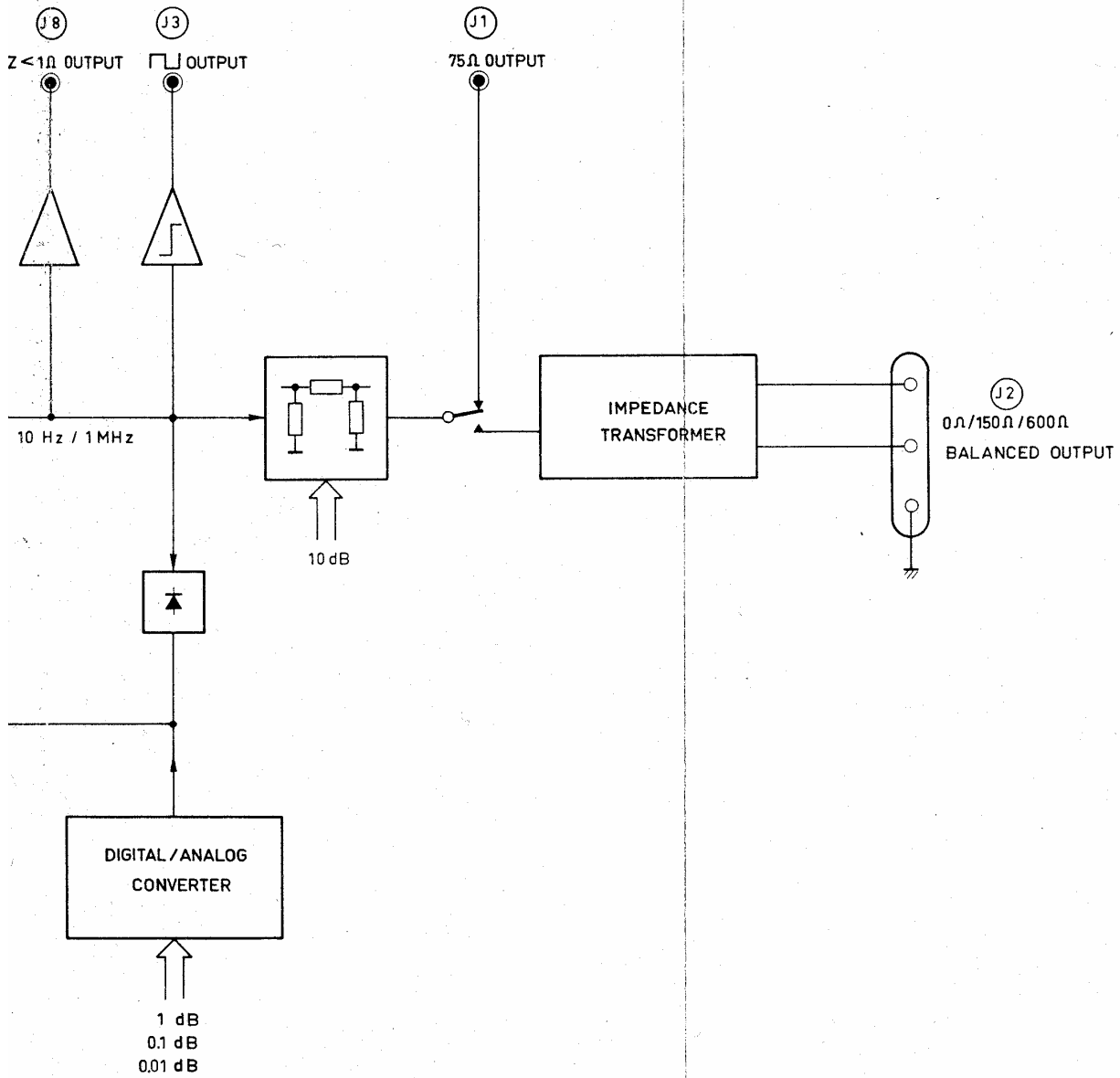

PLATE III - 1

2230A . PRINCIPLE OF OPERATION

Lever/indicator switches for digital frequency setting.

Indicator lights permitting to compare the output frequency in Generator or Sweeper mode with the digital display of switches K2.

Mode selection of output frequency setting :

- Key **SYNTH.** pressed : digital setting by switches **K2**.
- Key **GENER.** pressed : analogical setting by verniers **P1**.
- Key **SWEEP.** pressed : analogical setting by verniers **P1** and sweep by external signal applied to connector **J7**.

Analogical setting of output frequency in Generator or Sweeper mode.

Square-wave output.
0V, 5V or 10V amplitude selected by keyboard **K7**.

Selection of square-wave amplitude : 0V, 5V or 10V.

INHIB. key : permits to suppress the output signal without switching off the instrument.

On/Off key.

K2

DS3

K3

P1

J3

K7

K6

K1

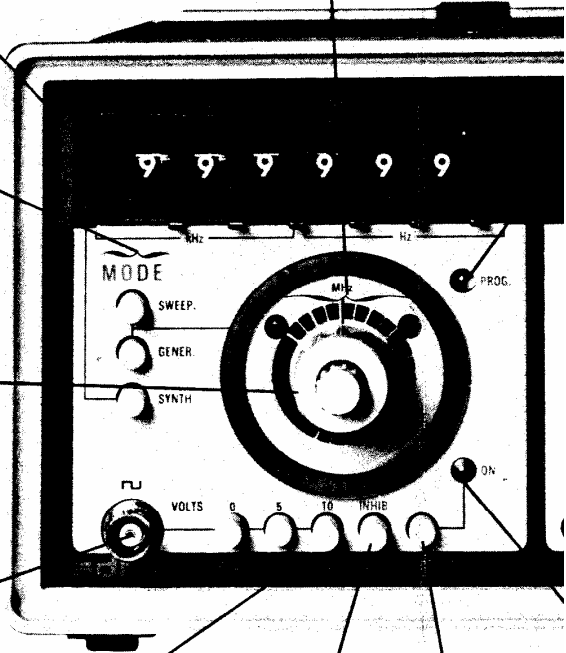

Digital frequency

Indicator lights permitting to compare the output frequency in Generator or Sweeper mode with the digital display of switches K2.

Remote programming indicator light.

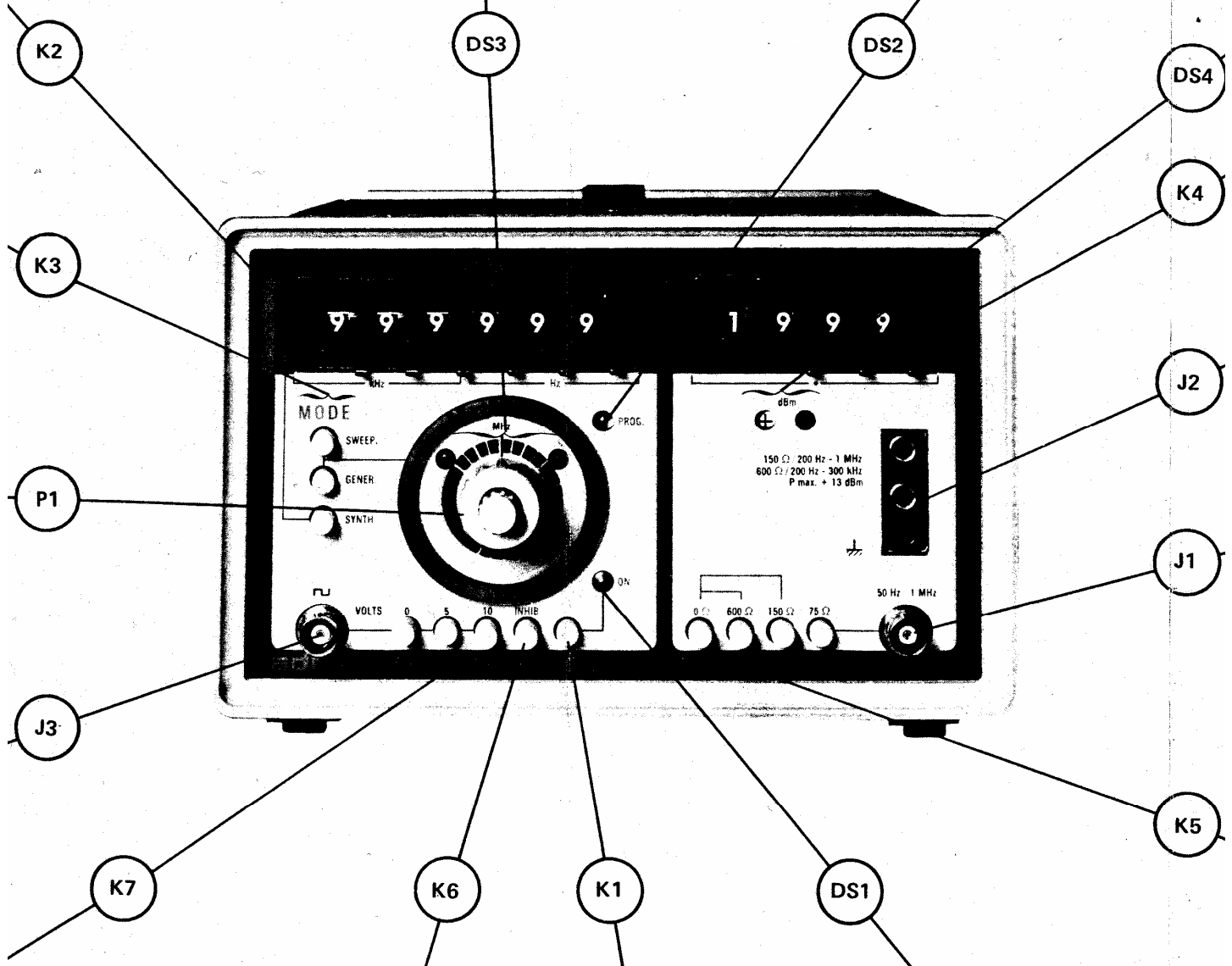

Amplitude: 0V,

INHIB. key : permits to suppress the output signal without switching off the instrument.

On/Off key.

ON indicator light.

pare the Sweeper
witches K2.

Remote programming indicator light.

Sign display of switches K4.

DS2

DS4

Lever/indicator switches for output level
setting.

K4

Balanced output with 0 Ω , 150 Ω or 600 Ω
impedance.

J2

Coaxial output with 75 Ω impedance.

J1

Output impedance selection :

- Key 75 Ω pressed : 75 Ω impedance,
level in dBm/75 Ω .
- Key 150 Ω pressed : 150 Ω impedance,
level in dBm/150 Ω .
- Key 600 Ω pressed : 600 Ω impedance,
level in dBm/600 Ω .
- Keys 0 Ω and 150 Ω pressed : $Z < 5 \Omega$,
e.m.f. equal to that of 150 Ω impedance.
- Keys 0 Ω and 600 Ω pressed : $Z < 20 \Omega$,
e.m.f. equal to that of 600 Ω impedance.

K5

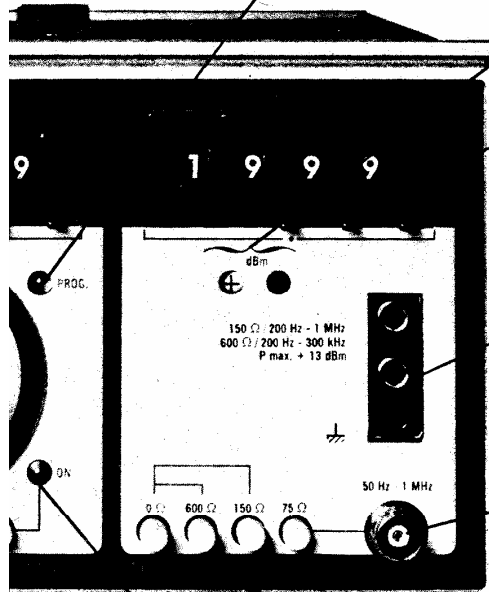

K1

On/Off key.

DS1

ON indicator light.

PLATE IV-1

2230A - FRONT-PANEL DESCRIPTION

PARALLEL BCD PROGRAMMING
(Option 010)

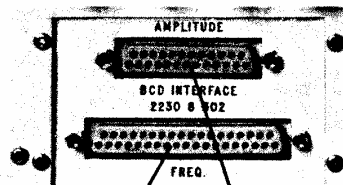

S04

S03

Output level programming connector

Output frequency programming connector

Z < 1Ω auxiliary output
Electromotive force variable from 0 dBm to +20 dBm/75Ω according to the main output level.

J8

Sw
Ma
Inp

1 m
50 n
off-r
Z < 1

IEEE BUS PROGRAMMING
(Option 020)

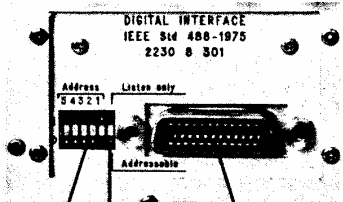

K10

K11

S05

Address selection switches

IEEE bus connector

Address enable switch

Internal reference output.
Frequency : 1 MHz
Level : +6 dBm/50Ω

J6

Ex
Frc
Le

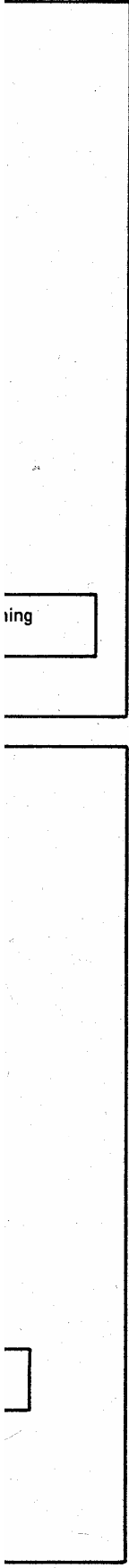

Z < 1Ω auxiliary output
Electromotive force variable from 0 dBm to +20 dBm/75Ω according to the main output level.

Sweep signal input.
Maximum amplitude : 10 Vp-p
Input impedance : 100 kΩ

Tracking output with 4 MHz
Level : +6 dBm/75Ω

J8

J7

J4

ing

I max. 50 mA
off -rms Z < 1Ω
SWEEP ±5V
1MHz +6dBm/50Ω
SYNCHRO 5MHz 0 + 13 dBm/50Ω
4/5 MHz +6dBm/75Ω

J6

J5

S01

Internal reference output.
Frequency : 1 MHz
Level : +6 dBm/50Ω

External reference input.
Frequency : 5 MHz
Level : 0 dBm to +13 dBm/50Ω

DIN connector providing +12 V, -12 V and -12 V regulated voltages.
Maximum current : 100 mA

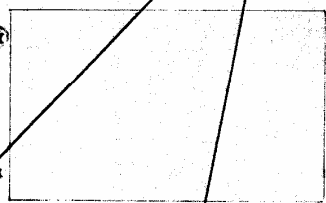

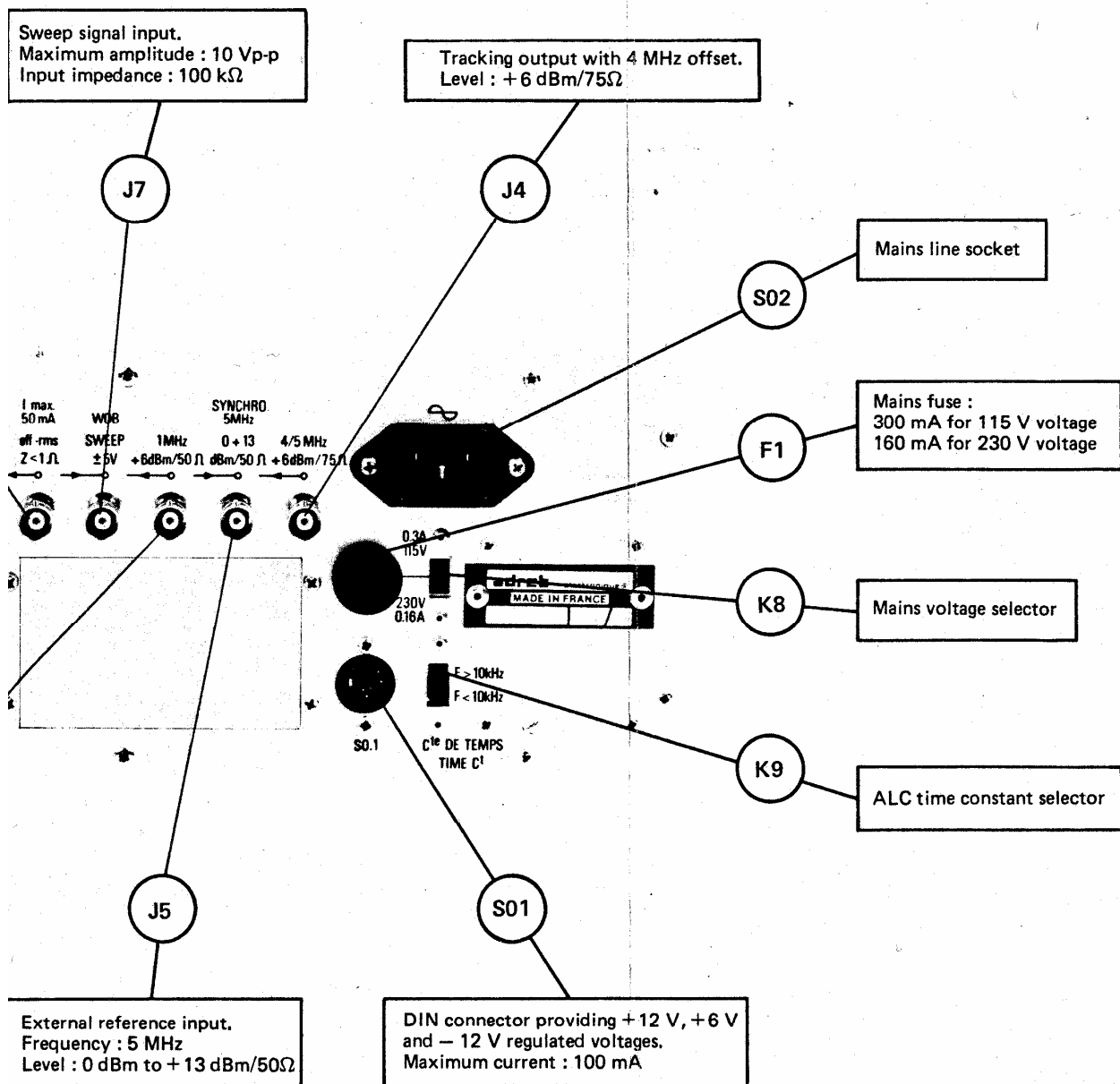

PLATE IV-2

2230A - REAR - PANEL DESCRIPTION

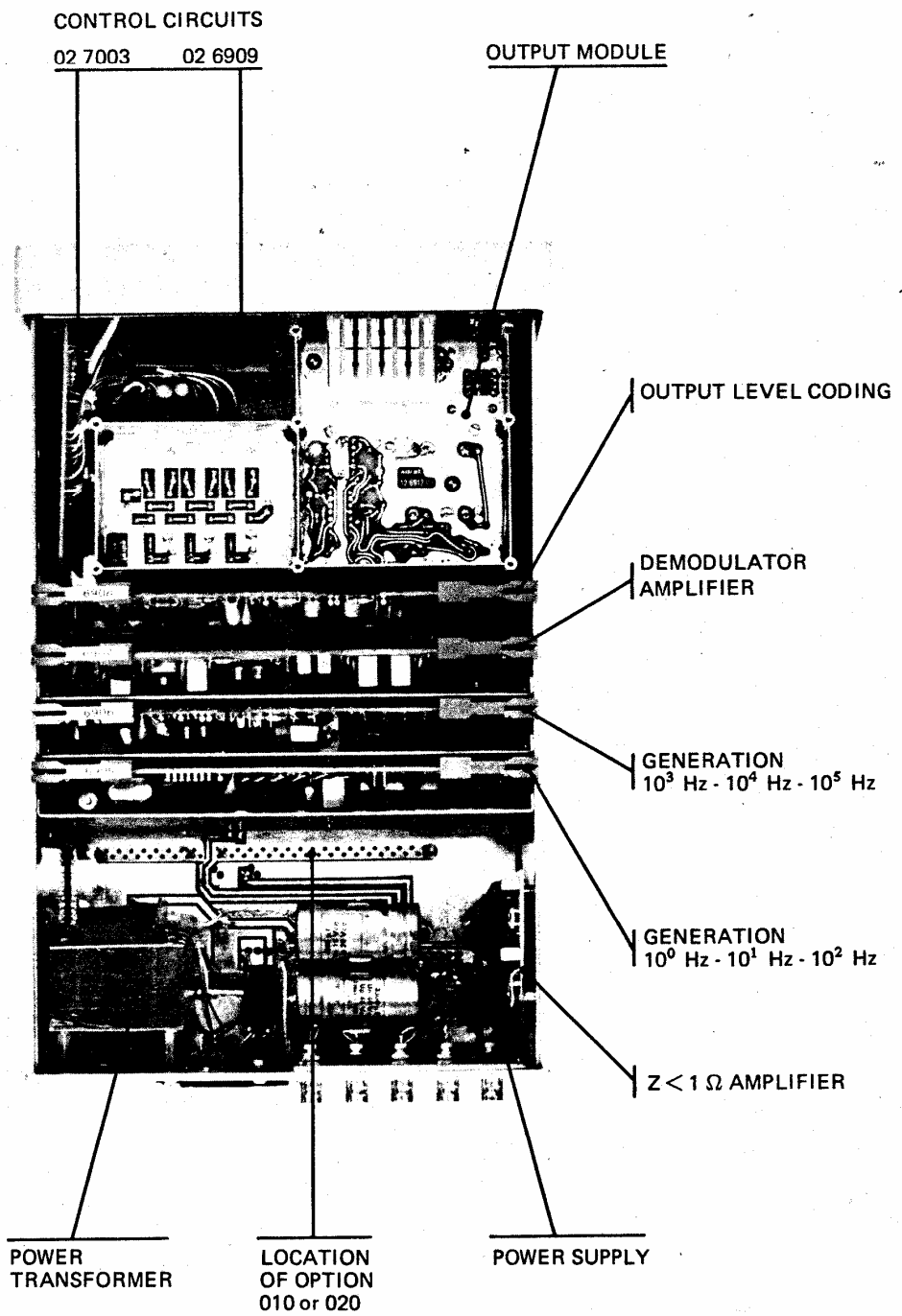
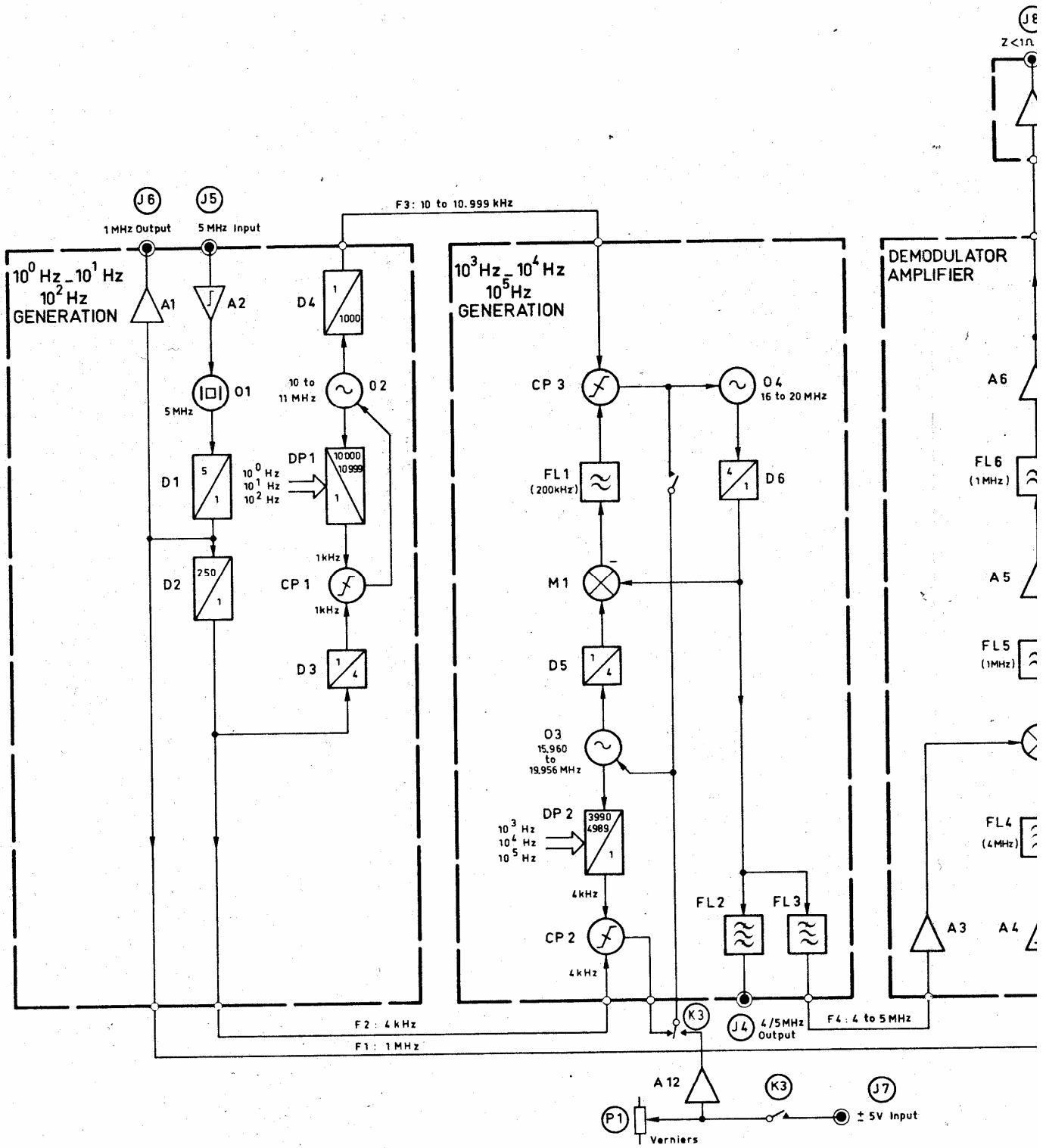
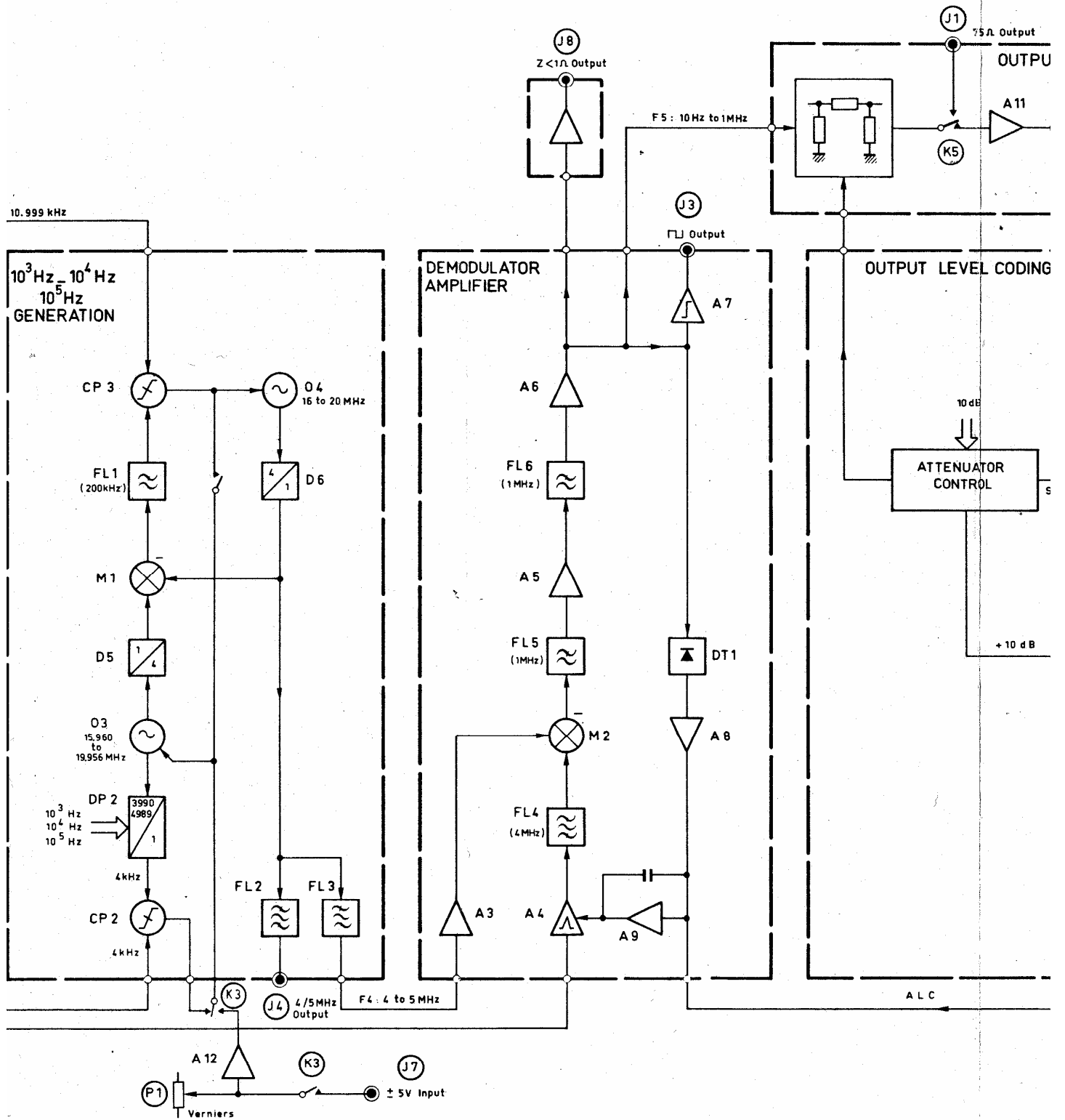

PLATE IV-3
2230A INTERNAL DESCRIPTION





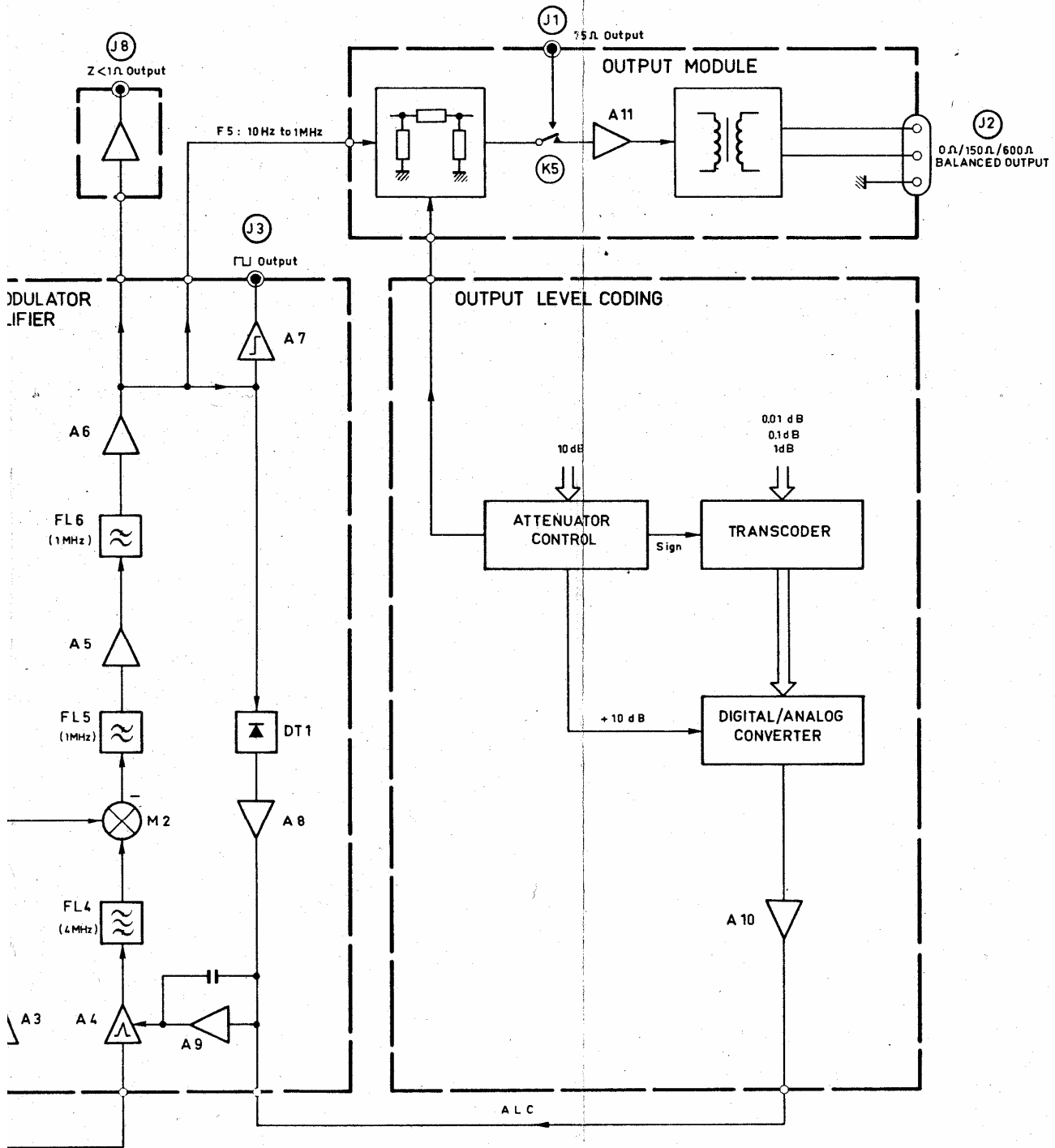

PLATE V.1
2230A . BLOCK DIAGRAM

Improving communications

You have just bought an **ADRET** instrument.

We would like to thank you for trusting our know-how, and we hope your choice will be satisfying.

However, despite how carefully it has been designed and manufactured, you may encounter some troubles.

To help us overcome these failures, and to solve them, we need to know the nature of your applications, the conditions of use and the difficulties encountered. You can help us by filling the reply card below.

On the other hand, we periodically publish a news **LETTER** dealing with our new products, our techniques, our organisation ...

By returning the coupon below, you will automatically be added to our new **LETTER** mailing list, and benefit from this useful mean of communication with you and between yourselves, users of **ADRET** equipments.

To tell us about any unusual or original applications you may have found particularly useful - we will publish them, with your permission - so that other users can enjoy the same benefits.



Instrument :

Model : Serial N° : Date of purchase :

Main applications and conditions of use :

.....

.....

Strong points : **Weak points - Difficulties encountered :**

.....

.....

Would you like to know more about the use of this instrument ?

.....

Would you be interested by a visit from a sales engineer ? Yes No

Would you like information on other Adret instruments ?

Yes **Which :**

.....

POSTCARD

Company :

Department :

Service :

Address :

.....

City :

Country :

Name/first name :

N° tel. :

N° telex :



ADRET Electronique
Service Commercial
BP 33

78192 TRAPPES CEDEX
FRANCE

ADRETELECTRONIQUE®



SCHEMAS ET NOMENCLATURES
DIAGRAMS AND NOMENCLATURES

ADRETELECTRONIQUE®

12, avenue Vladimir Komarov • BP 35 78192 Trappes Cedex • France • Tél. 01 39 79 79
Téléfax 01 39 00 74 • Tél. ADRETEL 697821 F • Site 67902077-00014 • CCF Paris 21 79794

T A B L E D E S M A T I E R E S

- * SIGNIFICATION des codes sous/ensembles et Réf. Adret
- * ARTICULATION et SYNOPTIQUE
- * SCHEMAS et NOMENCLATURES
- * LISTE des COMPOSANTS
- * LISTE des SOUS-ENSEMBLES MAINTENANCE
 - Outillage
 - Rechange 100%
 - Rechange 70%
 - Composants maintenance
- * Garantie et Assistance

C O N T E N T

- * MEANING of the part number and Adret codes
- * ARTICULATION and BLOCK DIAGRAM
- * DIAGRAMS and NOMENCLATURES
- * COMPONENTS LIST
- * RECOMMENDED SUB-ASSEMBLIES or PC board
 - Extended boards
 - Set of 100% of repairs
 - Set of 70% or repairs
 - Set of components
- * Warranty and Assistance

SIGNIFICATION des codes sous/ensembles et Ref. Adret

Dans le chapitre **SCHEMAS et NOMENCLATURES**, les deux premiers chiffres
 - du code s/ensemble (page 1)
 - et de la Ref. Adret (page 2 et suivantes),
 correspondent à une famille de produits.

Le détail de ces familles est donné dans le tableau ci-après.

Exemples

Page 1 : Articulation

PAGE	CODE S/ENSEMBLE PART NUMBER	DESCRIPTION	*	PART DESCRIPTION	PLAN DRAWING
- 2	0471004009-*	16 OPTION AMPLI STD	*	16 OPTION AMPLI 650MHZ .	C94.....A98*97
- 5	0271520000-*	13 ATTENUATEUR	*	13 ATTENUATOR ASSEMBLY .	A92.....C98...
- 6	0273210000-*	03 CARTE BF AMPLI STD ..	*	03 BF BOARD AMPLI 650MHZ	A93.....
- 7	0274740000-*	02 CDE AMPLI STD	*	02 CONTROL AMPLI 650MHZ.	C93.....A97

Soit le code s/ensemble **0271520000**.

Le tableau ci-après indique qu'il s'agit d'un sous-ensemble (02).

Page 2 et suivantes : Nomenclature

REPERE INDEXE	REF. ADRET PART NUMBER	DESCRIPTION	PART DESCRIPTION	FOURNISSEUR/PLAN SUPPLIER/DRAWING
001	0271520000	13 ATTENUATEUR	* 13 ATTENUATOR ASSEMBLY .	A92.....C98...
001	0273210000	03 CARTE BF AMPLI STD ..	* 03 BF BOARD AMPLI 650MHZ	A93.....
001	0274740000	02 CDE AMPLI STD	* 02 CONTROL AMPLI 650MHZ.	C93.....A97
B -001	1400217300	KM10 EMBASE*MALE*FIXAT. AVANT	* KM10 00 FRONT ANCHOR MALE ...	SEAELECTRO
B -002	1420020700	TRF254 M 20 MALE A SOUDER	* TRF254 M 20 MALE TO SOLDER	TRELEC
C	3100620000	FILTRE TRAVERSEE ZFN 5203-00A	* PINCH FILTER ZFN 5203-00A	TDK
C -001	3150042200	0,22MMF 5 50V20X 3439050 E224M	* 0,22MMF 5 50V20X 3439050	AVX
C -002	3800042200	CHIPS 0,22MMF 20X 25V Z5U-1808	* CHIPS 0,22MMF 20X 25V Z5U-1808	RTC
C -003	3120098200	8,2PF 2,5"E" 2222 678 09 828	* 8,2PF 2,5"E" 2222 678 09 828	COGECO
C -004	3800042200	CHIPS 0,22MMF 20X 25V Z5U-1808	* CHIPS 0,22MMF 20X 25V Z5U-1808	RTC

Soit la Ref. Adret **3150042200**.

Le tableau ci-après indique qu'il s'agit d'un condensateur Céramique (31) et rappelle son repère (C).

PRODUITS

Repère Famille

	01	Option Client
	02	Sous-Ensemble
	04	Option Usine
	10	Transformateurs
COMPOSANTS D'INTERCONNEXIONS	11	Fils et câbles
	12	Circuits imprimés
	13	Accessoires de câblage
	B	Connecteurs
	K	Commutateurs
	K	Relais

PRODUITS	Repère	Famille
		17 Protection, signalisation, lampes, fusibles...
		18 Galvanomètre, compteur horaire...
		19 Accessoires pour composants d'interconnexions
RESISTANCES	R	20 Thermistances CTN - CTP
	P	21 Potentiomètres
	R	22,23 Résistances usage courant
	R	24 Résistances usage courant
	R	25,26 Résistances à couche métallique
	R	27 Résistances très haute précision
	R	28 Résistances bobinées
	R	29 Résistances miniatures
CONDENSATEURS	C	31 Condensateurs céramiques
	C	32 Condensateurs film plastique
	C	33 Condensateurs mica
	C	35 Condensateurs électrochimiques
	C	36 Condensateurs variables
	C	37 Condensateurs tantales
	C	38 Condensateurs CHIPS, pastille céramique
		39 Accessoires
SEMI-CONDUCTEURS	D	40 Cellule photo émissive
	SN	41 Circuits intégrés logiques
	SN	42 Circuits intégrés analogiques
	Q	43 Transistors
	Q	44 Transistors à effet de champ
	D	45 Diodes et varicaps
	D	46 Diodes Zener
		48 Circuits hybrides
		49 Accessoires
AUTRES COMPOSANTS ELECTRONIQUES	Y	51 Quartz et accessoires
	F	52 Filtre
	L	53 Inductances surmoulées
		54 Composants pour bobinages
		55 Tubes ferrites
		56 Composants pour bobinages
		57 Accumulateur
		59 Transducteur
PIECES DETACHEES MECANIQUES		61 Vis
		62 Ecrous
		63 Rondelles
		64 Rivets, plots, circlips ...
		65 Boutons, cadrans ...
		67 Entretoises
MECANIQUE		71, à 91

MEANING of the "part number" and "Ref. Adret" codes

In the **DIAGRAMS and NOMENCLATURES** chapter, the two first numbers of

- the part number (page 1)
 - and the Ref. Adret (page 2 and following),
- correspond to a product-family.

The details of those families are given in the following list.

Examples

Page 1 : Articulation

PAGE	CODE S/ENSEMBLE PART NUMBER	DESCRIPTION	*	PART DESCRIPTION	PLAN DRAWING
- 2	0471004009-*	16 OPTION AMPLI STD	*	16 OPTION AMPLI 650MHZ .	C94.....A98*97
- 5	0271520000-*	13 ATTENUATEUR	*	13 ATTENUATOR ASSEMBLY .	A92.....C98...
- 6	0273210000-*	03 CARTE BF AMPLI STD ..	*	03 BF BOARD AMPLI 650MHZ	A93.....
- 7	0274740000-*	02 CDE AMPLI STD	*	02 CONTROL AMPLI 650MHZ.	C93.....A97

Take the part number **0271520000**.

The following list indicates that it concerns a sub-assembly (02).

Page 2 and following : Nomenclature

REFERE INDEXE	REF. ADRET PART NUMBER	DESCRIPTION	PART DESCRIPTION	FOURNISSEUR/PLAN SUPPLIER/DRAWING
001	0271520000	13 ATTENUATEUR	* 13 ATTENUATOR ASSEMBLY .	A92.....C98...
001	0273210000	03 CARTE BF AMPLI STD ..	* 03 BF BOARD AMPLI 650MHZ	A93.....
001	0274740000	02 CDE AMPLI STD	* 02 CONTROL AMPLI 650MHZ.	C93.....A97
B -001	1400217300	KMV10 EMBASE'MALE'FIXAT. AVANT	* KMV10 00 FRONT ANCHOR MALE ...	SEAELECTRO
B -002	1420020700	TRF254 M 20 MALE A SOUDER	* TRF254 M 20 MALE TO SOLDER	TRELEC
C	3100620000	FILTRE TRAVERSEE ZFN 5203-00A	* PINCH FILTER ZFN 5203-00A	TDK
C -001	3150042200	0,22MMF 5 50V20X 3439050 E224M	* 0,22MMF 5 50V20X 3439050	E224M AVX
C -002	3800042200	CHIPS 0,22MMF 20X 25V Z5U-1808	* CHIPS 0,22MMF 20X 25V Z5U-1808	RTC
C -003	3120098200	8,2PF 2,5"E" 2222 678 09 828	* 8,2PF 2,5"E" 2222 678 09 828	COGECO
C -004	3800042200	CHIPS 0,22MMF 20X 25V Z5U-1808	* CHIPS 0,22MMF 20X 25V Z5U-1808	RTC

Take the Ref. Adret **3150042200**.

The following list indicates that it concerns a ceramic capacitor (31) and recalls its reference (C).

PRODUCTS

Reference Family

	01	Customer Option	
	02	Sub-Assembly	
	04	Factory Option	
INTERCONNECTION COMPONENTS	10	Transformers	
	11	Cables assembly	
	12	Printed circuits	
	13	Accessories	
	B	14	Connectors
	K	15	Switches
K	16	Relays	

PRODUCTS

Reference Family

		17	Protection, signalling, lights, fuses ...
		18	Galvanometer, time counter ...
		19	Accessories for interconnection components
RESISTORS	R	20	Thermistors CTN - CTP
	P	21	Potentiometers
	R	22,23	Resistors for running use
	R	24	Resistors for running use
	R	25,26	Resistors with metallic sheet
	R	27	Resistors very high accuracy
	R	28	Winded resistors
	R	29	Miniature resistors
CAPACITORS	C	31	Ceramic capacitors
	C	32	Capacitors film plastic
	C	33	Capacitors mica
	C	35	Electrochemical capacitors
	C	36	Variable capacitors
	C	37	Tantalum capacitors
	C	38	CHIPS capacitors, ceramic pastille
		39	Accessories
SEMI-CONDUCTORS	D	40	Photo emitting cell
	SN	41	Logic printed circuits
	SN	42	Analog printed circuits
	Q	43	Transistors
	Q	44	Field effect transistors
	D	45	Diodes and varicaps
	D	46	Zener diodes
		48	Hybrid circuits
		49	Accessories
OTHERS ELECTRONIC COMPONENTS	Y	51	Crystals and accessories
	F	52	Filter
	L	53	Surmoulded inductors
		54	Components for winding
		55	Ferrite tubes
		56	Components for winding
		57	Battery
		59	Transducer
MECANIC REPLACEMENT PARTS		61	Screws
		62	Nuts
		63	Washers
		64	Clinches, contacts, circlips ...
		65	Knobs, faces ...
		67	Spacer round
MECANICAL		71	to 91

PAGE	CODE S/ENSEMBLE PART NUMBER	DESCRIPTION	*	PART DESCRIPTION	PLAN DRAWING
- 2	0422301002-*	00 AVANT HABILLAGE Z=0 . 2230A	*	00 AVANT HABILLAGE Z=0 . 2230A	
- 3	0269050000-*	14 1ER GENERATION 2230A	*	14 FIRST GENERATION 2230A	M932502.A976905
- 5	0269060000-*	17 2EME GENERATION 2230A	*	17 SECOND GENERATION ... 2230A	M932344.E976906
- 8	0269070000-*	13 CARTE AMPLIFICATEUR . 2230A	*	13 AMPLIFIER BOARD 2230A	G932353.A976907
- 11	0269080000-*	06 CARTE COMMANDE NIVEAU 2230A	*	06 LEVEL CONTROL BOARD . 2230A	G932349.A976908
- 13	0269100000-*	11 BAQUET DE SORTIE 2230A	*	11 OUTPUT MODULE 2230A	J920871.C976910
- 14	0269110000-*	03 ATTENUATEUR 2230A	*	03 ATTENUATOR 2230A	C932524.....
- 15	0269120000-*	11 AMPLI SYMETRIQUE 2230A	*	11 SYMMETRICAL AMPLI ... 2230A	H932351.1&2/2..
- 16	0270080300-*	02 CHASSIS EQUIPE Z0 ... 2230A	*	02 FITTED CHASSIS Z0 ... 2230A	J910214.....
- 17	0269150100-*	07 PORTEUR EQUIPE 2230A	*	07 FITTED MOTHER BD 2230A	B920953.A976915
- 18	0270110000-*	08 PLAQUE AVANT MONTEE . 2230A	*	08 ASSEM. FRONT PLATE .. 2230A	L920934.....
- 19	0269090000-*	03 COMMUTATEUR TTL 2230A	*	03 TTL SWITCH 2230A	D932366.....
- 20	0270030100-*	09 COMMUTATEUR MODE 2230A	*	09 MODE SWITCH 2230A	J932523.B977003
- 21	0270100000-*	04 BLOC ROUES CODEES ... 2230A	*	04 SPIN WHEELS BLOCK ... 2230A	D920933.....
- 22	0270940000-*	01 AMPLI Z=0 2230A	*	01 AMPLI Z=0 2230A	E932549.A977094
- 23	0422308301-*	08 OPTION 2 IIEEE 2230A	*	08 OPTION 2 IIEEE 2230A	F932565
- 24	0269970000-*	06 CARTE REGISTRE IIEEE . 2230A	*	06 IIEEE REGISTER BOARD . 2230A	E932563.B976997
- 25	0274880000-*	02 CARTE ISOLATION IIEEE 2230A	*	02 IIEEE INSULATING BOARD 2230A	D932961.C977488
- 27	0422308302-*	03 OPTION 1 BCD 2230A	*	03 OPTION 1 BCD 2230A	A932555(2).....
- 28	0269130000-*	01CARTE OPTION BCD 2230A	*	01 BCD OPTION BOARD 2230A	932547. 976913

REPERE INDEXE	REF. ADRET PART NUMBER	DESCRIPTION	PART DESCRIPTION	FOURNISSEUR/PLAN SUPPLIER/DRAWING	QTE QTY
	001 0422301002	00 AVANT HABILLAGE Z=0 . 2230A	* 00 AVANT HABILLAGE Z=0 . 2230A		1
	001 0422308301	08 OPTION 2 IEEE 2230A	* 08 OPTION 2 IEEE 2230A F932565		1
	001 0422308302	03 OPTION 1 BCD 2230A	* 03 OPTION 1 BCD 2230A A932555(2).....		1
ZO	0122309001	KIT ASSEMBLAGE RACK 3U 1X2230A	* KIT ASSEMBLAGE RACK 3U 1X2230A A910165		1
ZO	0122309002	KIT ASSEMBLAGE RACK 3U 2X2230A	* KIT ASSEMBLAGE RACK 3U 2X2230A A910165		1
ZO	0122309003	00 PROLONGATEUR 27 1 GEN 2230A	* 00 PROLONGATEUR 27 1 GEN 2230A *932610.....		1
ZO	0122309004	00 PROLONGATEUR 27 2 GEN 2230A	* 00 PROLONGATEUR 27 2 GEN 2230A *932611.....		1
ZO	0122309005	00 PROLONG. OPT.IEEE+BCD 2230A	* 00 PROLONG. OPT.IEEE+BCD 2230A A93.....		1
ZO	0122309006	00 PROLONG. CDE NIVEAU 2230A	* 00 PROLONG. CDE NIVEAU 2230A A93.....		1
ZO	0122309007	00 PROLONGATEUR AMPLI .. 2230A	* 00 PROLONGATEUR AMPLI .. 2230A A93.....		1
ZO	0422308304	01 OPTION 20/21MHZ 2230A	* 01 OPTION 20/21MHZ 2230A A92 1&2/2		1

 *0422301002 00 AVANT HABILLAGE Z=0 . 2230A * 00 AVANT HABILLAGE Z=0 . 2230A *

REPÈRE INDEXE	REF. ADRET PART NUMBER	DESCRIPTION	PART DESCRIPTION	FOURNISSEUR/PLAN SUPPLIER/DRAWING	QTE QTY
001	0269050000 14	1ER GENERATION	2230A * 14 FIRST GENERATION	2230A M932502.A976905	1
001	0269060000 17	2EME GENERATION	2230A * 17 SECOND GENERATION ...	2230A M932344.E976906	1
001	0269070000 13	CARTE AMPLIFICATEUR .	2230A * 13 AMPLIFIER BOARD	2230A G932353.A976907	1
001	0269080000 06	CARTE COMMANDE NIVEAU	2230A * 06 LEVEL CONTROL BOARD .	2230A G932349.A976908	1
001	0269100000 11	BAQUET DE SORTIE	2230A * 11 OUTPUT MODULE	2230A J920871.C976910	1
001	0270080300 02	CHASSIS EQUIPE ZO ...	2230A * 02 FITTED CHASSIS ZO ...	2230A J910214.....	1
ZO	0422301300 02	LOT HABILLAGE	FANTOME * 02 LOT HABILLAGE	FANTOME	1

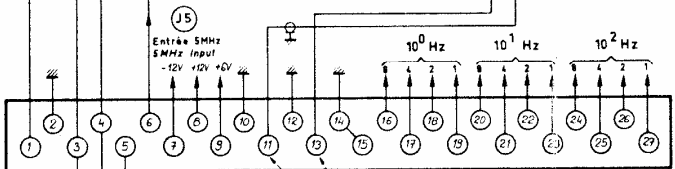
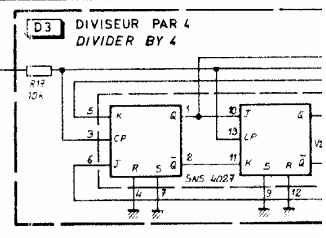
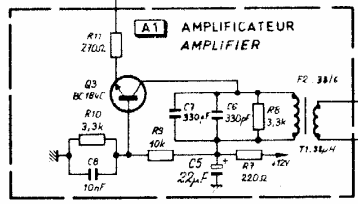
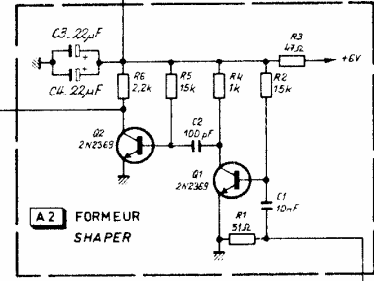
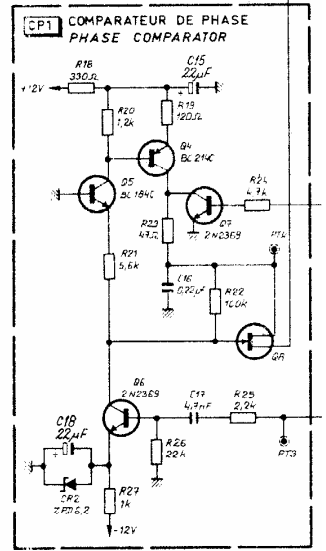
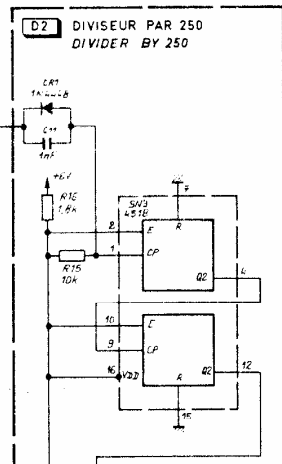
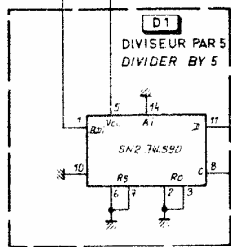
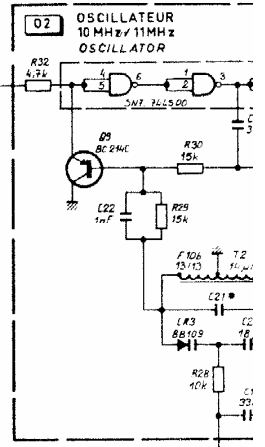
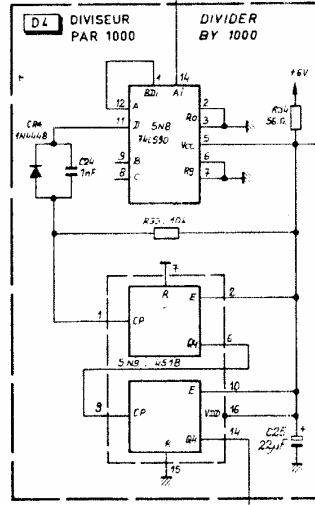
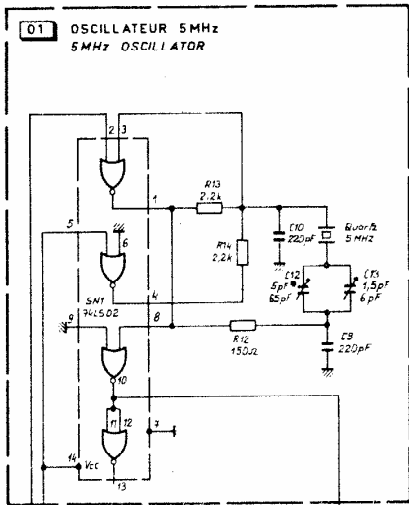

F1: 1MHz
vers DEMODULATEUR AMPLIFICATEUR
to DEMODULATOR AMPLIFIER

F2: 4kHz vers GENERATION 10³ Hz, 10⁴ Hz, 10⁵ Hz

F3: 10kHz/11kHz vers GENERATION 10³ Hz, 10⁴ Hz, 10⁵ Hz

* Ajusté en fabrication
Factory adjusted

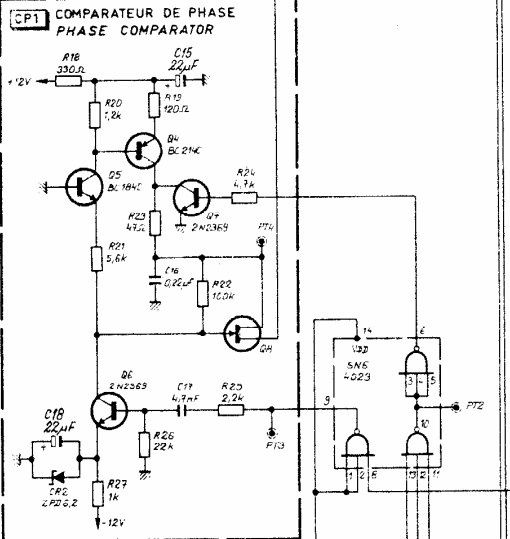
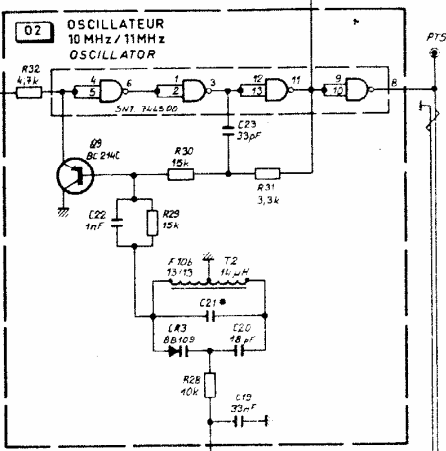
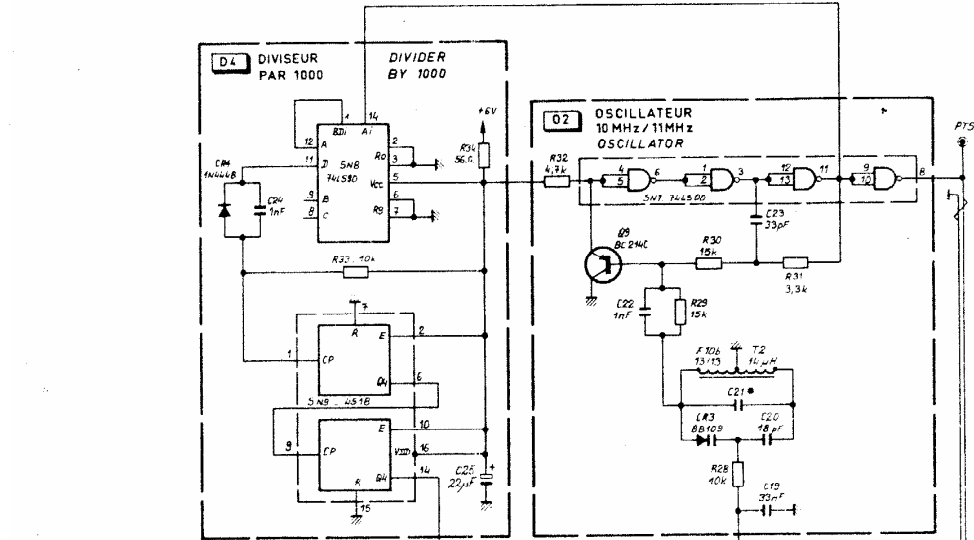

**DP1 DIVISEUR PROGRAMMABLE
PROGRAMMABLE DIVIDER**

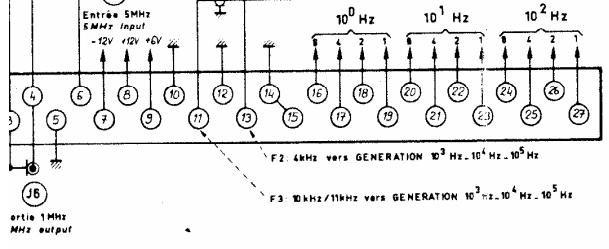
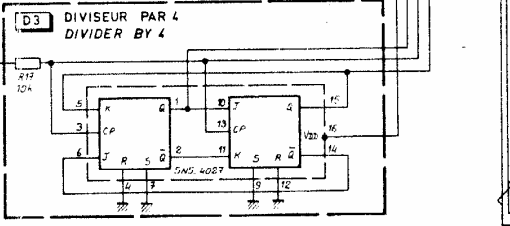
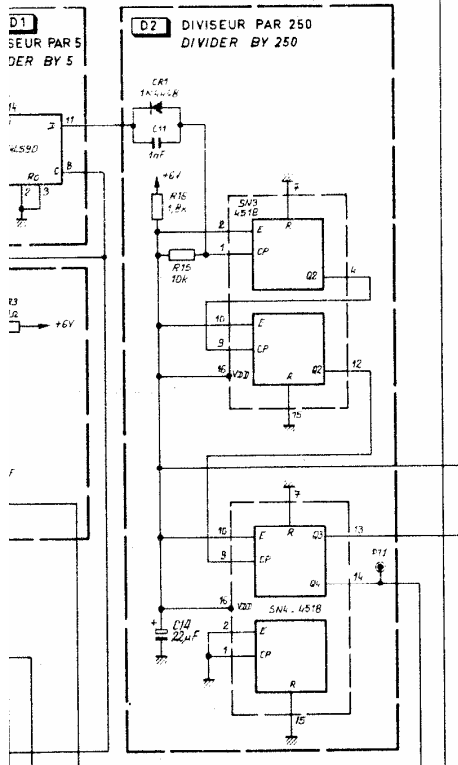
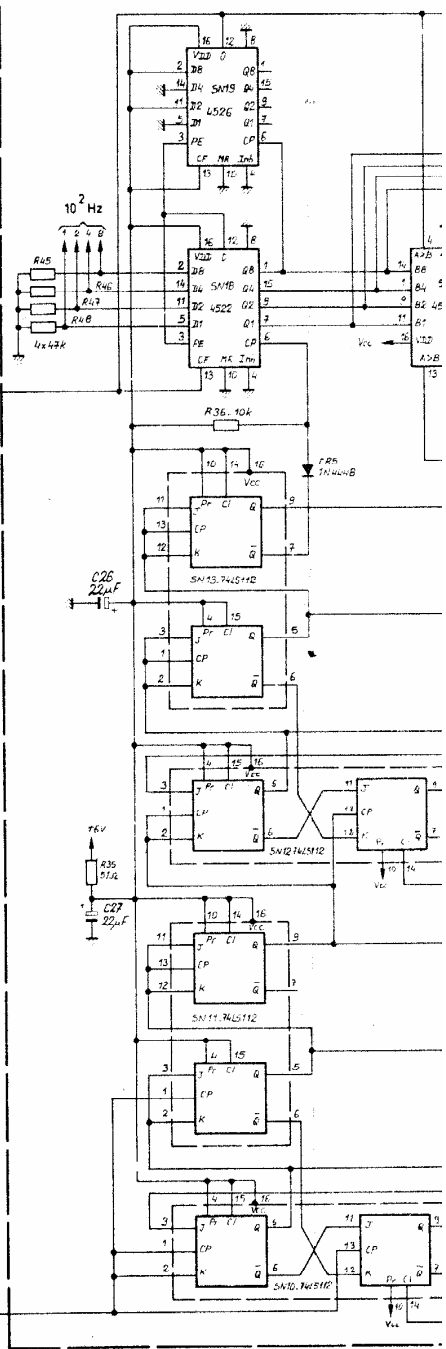

• Ajusté en fabrication
Factory adjusted

DP1 DIVISEUR PROGRAMMABLE
PROGRAMMABLE DIVIDER

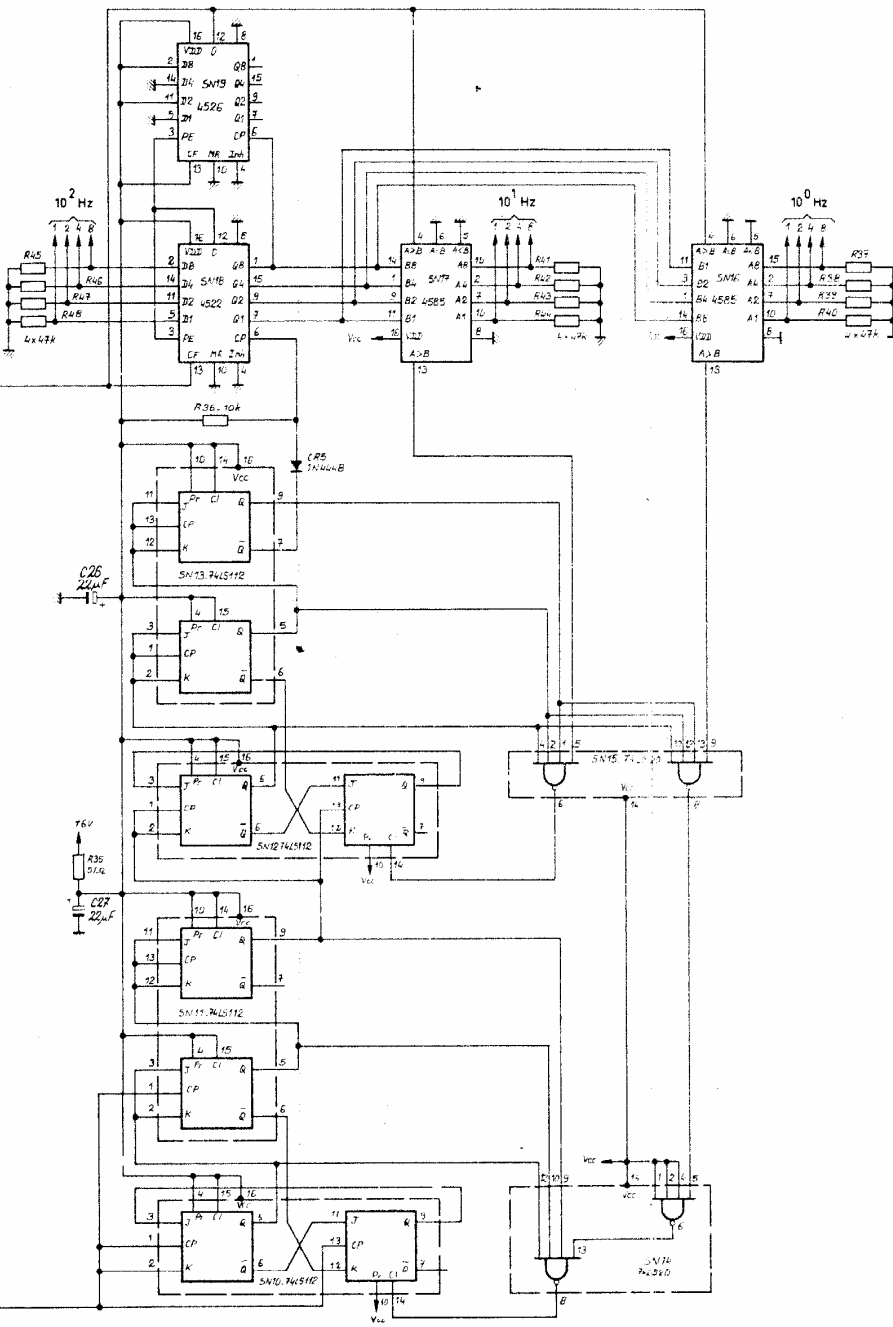
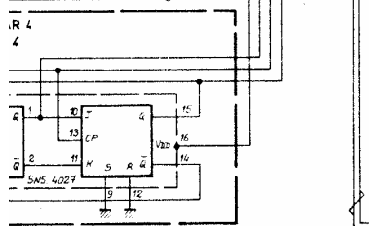
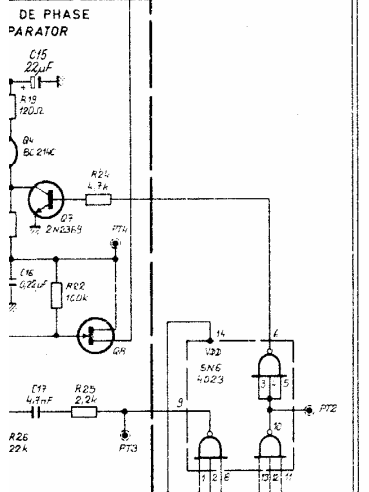
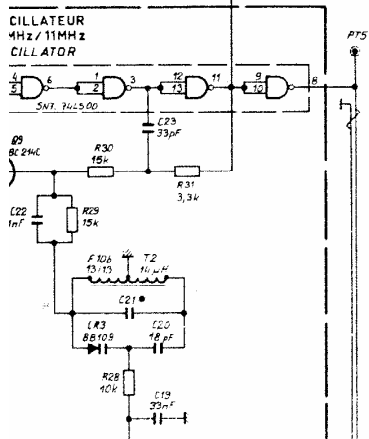

* Ajusté en fabrication
Factory adjusted

Ce document ne peut être communiqué ni reproduit sans autorisation		ndt électronique	DATE : JUILLET 1978
ETUDE	DESSIN	VERIFIE	2230 A
ACORT	H.V.	GENERATION	10 ⁰ Hz - 10 ¹ Hz - 10 ² Hz
			PAGE : 1 / 1
			976905A

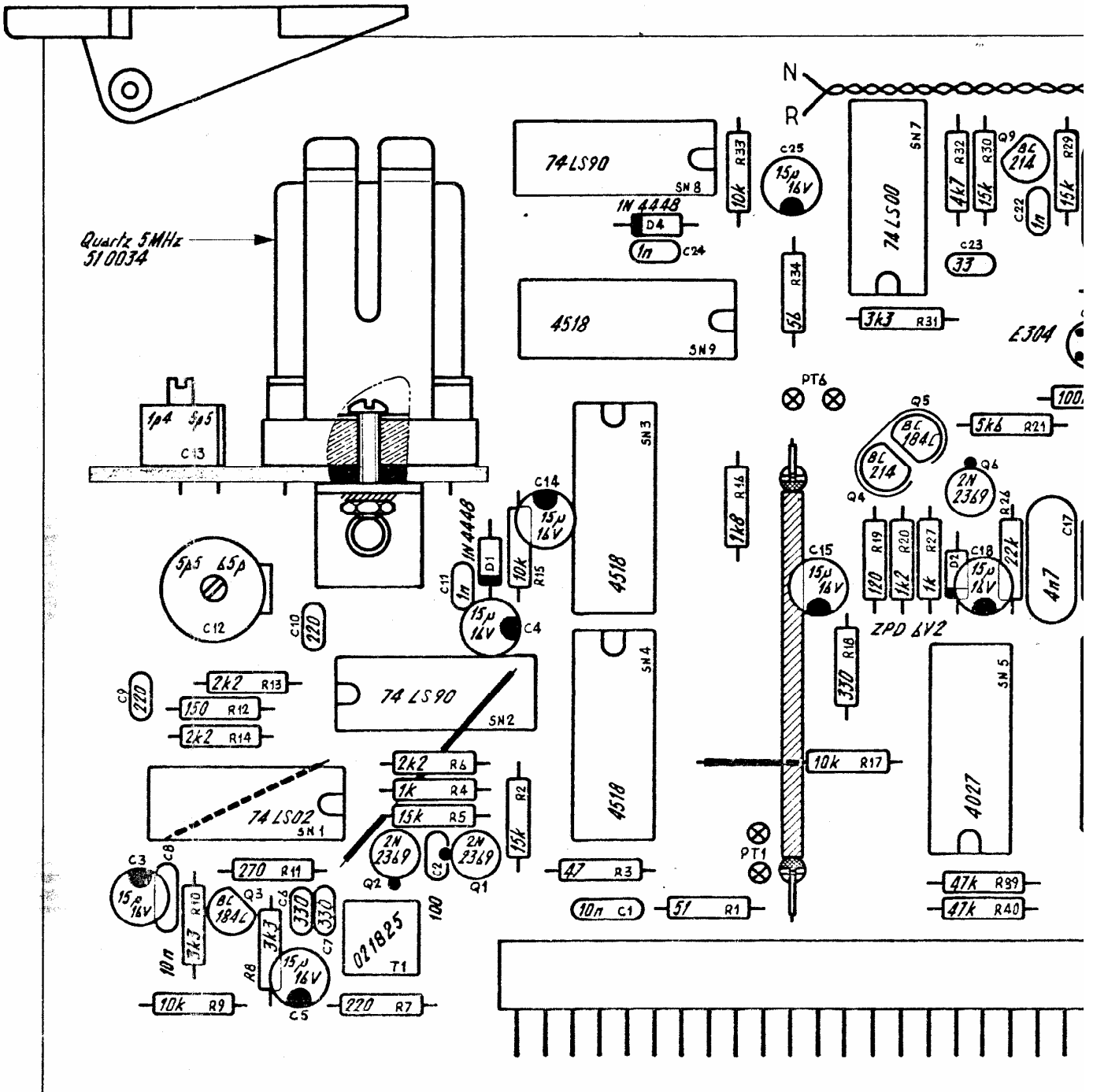

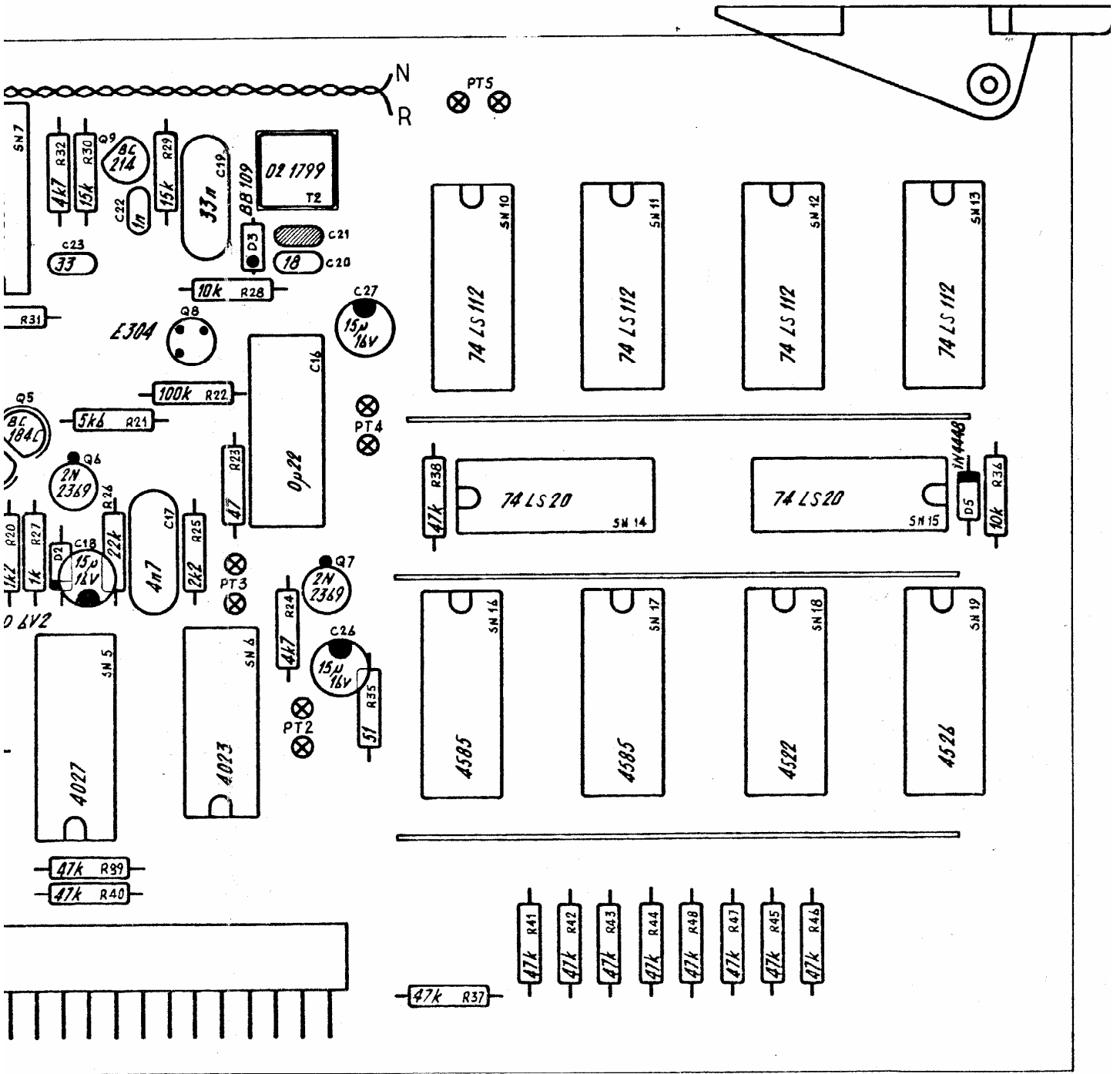

REPERE INDEXE	REF. ADRET PART NUMBER	DESCRIPTION	PART DESCRIPTION	FOURNISSEUR/PLAN SUPPLIER/DRAWING	QTE QTY
B -001	1427011600	TM 27 MCIG MALE*CARTE*	* TM 27 MCIG MALE	TRELEC	1
C -001	3150031000	10NF 5,08 63V GOX 767 14	* 10NF 5,08 63V GOX 767 14	LCC	1
C -002	3120011000	100PF 2,5 'N10' 2222 680 58 101	* 100PF 2,5 'N10' 2222 680 58 101	COGECO	1
C -003	3700180000	22MMF/16V 5,08 ... STAND L TAG	* 22MMF/16V 5,08 ... STAND L TAG	STC	1
C -004	3700180000	22MMF/16V 5,08 ... STAND L TAG	* 22MMF/16V 5,08 ... STAND L TAG	STC	1
C -005	3700180000	22MMF/16V 5,08 ... STAND L TAG	* 22MMF/16V 5,08 ... STAND L TAG	STC	1
C -006	3120013300	330PF 2,5 'N33' 2222 680 58 331	* 330PF 2,5 'N33' 2222 680 58 331	COGECO	1
C -007	3120013300	330PF 2,5 'N33' 2222 680 58 331	* 330PF 2,5 'N33' 2222 680 58 331	COGECO	1
C -008	3150031000	10NF 5,08 63V GOX 767 14	* 10NF 5,08 63V GOX 767 14	LCC	1
C -009	3120012200	220PF 2,5 'N22' 2222 680 58 221	* 220PF 2,5 'N22' 2222 680 58 221	COGECO	1
C -010	3120012200	220PF 2,5 'N22' 2222 680 58 221	* 220PF 2,5 'N22' 2222 680 58 221	COGECO	1
C -011	3120021000	1 NF 2,5 2222 630 51 102	* 1 NF 2,5 2222 630 51 102	COGECO	1
C -012	3600070000	5.5/65PF JAUNE 2222 808 32659	* 5.5/65PF YELLOW 2222 808 32659	RTC(CO10)	1
C -013	3600150000	1.4/5,5PF GRISE CO10 808-11558	* 1.4/5,5PF GREY CO10 808-11558	RTC(CO10)	1
C -014	3700180000	22MMF/16V 5,08 ... STAND L TAG	* 22MMF/16V 5,08 ... STAND L TAG	STC	1
C -015	3700180000	22MMF/16V 5,08 ... STAND L TAG	* 22MMF/16V 5,08 ... STAND L TAG	STC	1
C -016	3224220000	0,22MMF 15(10X40V)POLYC CK868	* 0,22MMF 15(10X40V)POLYC CK868	GAM	1
C -017	3232470000	4700PF 10(10X400V)222236855472	* 4700PF 10(10X400V)222236855472	COGECO	1
C -018	3700180000	22MMF/16V 5,08 ... STAND L TAG	* 22MMF/16V 5,08 ... STAND L TAG	STC	1
C -019	3233330000	33NF 10(10X250V)222236845333	* 33NF 10(10X250V)222236845333	COGECO	1
C -020	3120001800	18PF 2,5 'J' 2222 680 10 189	* 18PF 2,5 'J' 2222 680 10 189	COGECO	1
C -021	3100000000	CONDENS CERAMIQUE A AJUSTER	* CERAMIC CAPACITORS TO ADJUST	ADRET	1
C -022	3120021000	1 NF 2,5 2222 630 51 102	* 1 NF 2,5 2222 630 51 102	COGECO	1
C -023	3120003300	33PF 2,5 2222 680 10 339	* 33PF 2,5 2222 680 10 339	COGECO	1
C -024	3120021000	1 NF 2,5 2222 630 51 102	* 1 NF 2,5 2222 630 51 102	COGECO	1
C -025	3700180000	22MMF/16V 5,08 ... STAND L TAG	* 22MMF/16V 5,08 ... STAND L TAG	STC	1
C -026	3700180000	22MMF/16V 5,08 ... STAND L TAG	* 22MMF/16V 5,08 ... STAND L TAG	STC	1
C -027	3700180000	22MMF/16V 5,08 ... STAND L TAG	* 22MMF/16V 5,08 ... STAND L TAG	STC	1
D -001	4500310000	1 N 4448	* 1 N 4448	ITT	1
D -002	4600050000	ZPD 6,2	* ZPD 6,2	ITT	1
D -003	4500452200	BB 409 ENTRE 9&11,5PF A 11V CE	* BB 409 INPUT 9&11.5PF A 11V IC	ADRET C.ENTREE.	1
D -004	4500310000	1 N 4448	* 1 N 4448	ITT	1
D -005	4500310000	1 N 4448	* 1 N 4448	ITT	1
Q -001	4300050000	2N2369 A	* 2N2369 A	MOTOROLA	1
Q -002	4300050000	2N2369 A	* 2N2369 A	MOTOROLA	1
Q -003	4300190000	BC550C /414C/413C/549C(BC184C)	* BC550C /414C/413C/549C(BC184C)	RTC	1
Q -004	4300110000	BC560C /416C/415C/559C(BC214C)	* BC560C /413C/415C/559C(BC214C)	RTC	1
Q -005	4300190000	BC550C /414C/413C/549C(BC184C)	* BC550C /414C/413C/549C(BC184C)	RTC	1
Q -006	4300050000	2N2369 A	* 2N2369 A	MOTOROLA	1
Q -007	4300050000	2N2369 A	* 2N2369 A	MOTOROLA	1
Q -008	4400080000	2N4416	* 2N4416	PURCHASE CODE *930849	1
Q -009	4300110000	BC560C /416C/415C/559C(BC214C)	* BC560C /413C/415C/559C(BC214C)	RTC	1
R -001	2210005100	51R 5% N4	* 51R 5% N4	SOUCOR	1
R -002	2210031500	15K 5% N4	* 15K 5% N4	SOUCOR	1
R -003	2210004700	47R 5% N4	* 47R 5% N4	SOUCOR	1
R -004	2210021000	1K0 5% N4	* 1K0 5% N4	SOUCOR	1
R -005	2210031500	15K 5% N4	* 15K 5% N4	SOUCOR	1
R -006	2210022200	2K2 5% N4	* 2K2 5% N4	SOUCOR	1
R -007	2210012200	220R 5% N4	* 220R 5% N4	SOUCOR	1
R -008	2210023300	3K3 5% N4	* 3K3 5% N4	SOUCOR	1
R -009	2210031000	10K 5% N4	* 10K 5% N4	SOUCOR	1
R -010	2210023300	3K3 5% N4	* 3K3 5% N4	SOUCOR	1
R -011	2210012700	270R 5% N4	* 270R 5% N4	SOUCOR	1
R -012	2210011500	150R 5% N4	* 150R 5% N4	SOUCOR	1
R -013	2210022200	2K2 5% N4	* 2K2 5% N4	SOUCOR	1
R -014	2210022200	2K2 5% N4	* 2K2 5% N4	SOUCOR	1
R -015	2210031000	10K 5% N4	* 10K 5% N4	SOUCOR	1
R -016	2210021800	1K8 5% N4	* 1K8 5% N4	SOUCOR	1
R -017	2200031000	10K 5% N4	* 10K 5% N4	SOUCOR	1
R -018	2210013300	330R 5% N4	* 330R 5% N4	SOUCOR	1
R -019	2210011200	120R 5% N4	* 120R 5% N4	SOUCOR	1
R -020	2210021200	1K2 5% N4	* 1K2 5% N4	SOUCOR	1
R -021	2210025600	5K6 5% N4	* 5K6 5% N4	SOUCOR	1
R -022	2210041000	100K 5% N4	* 100K 5% N4	SOUCOR	1
R -023	2210004700	47R 5% N4	* 47R 5% N4	SOUCOR	1
R -024	2210024700	4K7 5% N4	* 4K7 5% N4	SOUCOR	1
R -025	2210022200	2K2 5% N4	* 2K2 5% N4	SOUCOR	1
R -026	2210032200	22K 5% N4	* 22K 5% N4	SOUCOR	1
R -027	2210021000	1K0 5% N4	* 1K0 5% N4	SOUCOR	1
R -028	2210031000	10K 5% N4	* 10K 5% N4	SOUCOR	1
R -029	2210031500	15K 5% N4	* 15K 5% N4	SOUCOR	1
R -030	2210031500	15K 5% N4	* 15K 5% N4	SOUCOR	1
R -031	2210023300	3K3 5% N4	* 3K3 5% N4	SOUCOR	1
R -032	2210024700	4K7 5% N4	* 4K7 5% N4	SOUCOR	1
R -033	2210031000	10K 5% N4	* 10K 5% N4	SOUCOR	1
R -034	2210005600	56R 5% N4	* 56R 5% N4	SOUCOR	1
R -035	2210005100	51R 5% N4	* 51R 5% N4	SOUCOR	1
R -036	2210031000	10K 5% N4	* 10K 5% N4	SOUCOR	1
R -037	2210034700	47K 5% N4	* 47K 5% N4	SOUCOR	1

REPERE INDEXE	REF. ADRET PART NUMBER	DESCRIPTION	PART DESCRIPTION	FOURNISSEUR/PLAN SUPPLIER/DRAWING	QTE QTY
R -038	2210034700	47K	5% N4 * 47K	5% N4 SOUCOR	1
R -039	2210034700	47K	5% N4 * 47K	5% N4 SOUCOR	1
R -040	2210034700	47K	5% N4 * 47K	5% N4 SOUCOR	1
R -041	2210034700	47K	5% N4 * 47K	5% N4 SOUCOR	1
R -042	2210034700	47K	5% N4 * 47K	5% N4 SOUCOR	1
R -043	2210034700	47K	5% N4 * 47K	5% N4 SOUCOR	1
R -044	2210034700	47K	5% N4 * 47K	5% N4 SOUCOR	1
R -045	2210034700	47K	5% N4 * 47K	5% N4 SOUCOR	1
R -046	2210034700	47K	5% N4 * 47K	5% N4 SOUCOR	1
R -047	2210034700	47K	5% N4 * 47K	5% N4 SOUCOR	1
R -048	2210034700	47K	5% N4 * 47K	5% N4 SOUCOR	1
SN -001	4150740200	SN 74 LS 02 N 3	* SN 74 LS 02 N 3	TEXAS	1
SN -002	4150749000	SN 74 LS 90 N 3	* SN 74 LS 90 N 3	TEXAS	1
SN -003	4160451800	C-MOS 4518	* C-MOS 4518	RTC	1
SN -004	4160451800	C-MOS 4518	* C-MOS 4518	RTC	1
SN -005	4160402700	C-MOS 4027	* C-MOS 4027	RTC	1
SN -006	4160402300	C-MOS 4023	* C-MOS 4023	RTC	1
SN -007	4150740000	SN 74 LS 00 N 3	* SN 74 LS 00 N 3	TEXAS	1
SN -008	4150749000	SN 74 LS 90 N 3	* SN 74 LS 90 N 3	TEXAS	1
SN -009	4160451800	C-MOS 4518	* C-MOS 4518	RTC	1
SN -010	4157411200	SN 74 LS 112 N	* SN 74 LS 112 N	'FU' TEXAS	1
SN -011	4157411200	SN 74 LS 112 N	* SN 74 LS 112 N	'FU' TEXAS	1
SN -012	4157411200	SN 74 LS 112 N	* SN 74 LS 112 N	'FU' TEXAS	1
SN -013	4157411200	SN 74 LS 112 N	* SN 74 LS 112 N	'FU' TEXAS	1
SN -014	4150742000	SN 74 LS 20 N 3	* SN 74 LS 20 N 3	TEXAS	1
SN -015	4150742000	SN 74 LS 20 N 3	* SN 74 LS 20 N 3	TEXAS	1
SN -016	4160458500	C-MOS 4585	* C-MOS 4585	'FU' RTC	1
SN -017	4160458500	C-MOS 4585	* C-MOS 4585	'FU' RTC	1
SN -018	4160452200	C-MOS 4522	* C-MOS 4522	RTC	1
SN -019	4160452600	C-MOS 4526	* C-MOS 4526	RTC	1
T -001	0218250000	00 F2 38X6 SPIRES 2230A	* 00 F2 38X6 TURNS 2230A	Z94 F2.....4H	1
T -002	0217990000	00 F10B 13+13 2200A	* 00 F10B 13+13 TURNS 2200A	Z94 F10B.....26	1
Y -001	5100550000	QUARTZ 5 MHZ . REF JJ05E QC36	* 5 MHZ CRYSTAL . REF JJ05E QC36	HYQ	1
Z0	0206780000	00 ETIQUETTE 6905 2230A	* 00 LABEL 6905 2230A	942375.....	1
Z1	1100010000	FIL NOIR KY30-04	* BLACK THREAD KY30-04	FILECA	0
Z1	1100030000	FIL ROUGE KY30-04	* RED THREAD KY30-04	FILECA	0
Z1	1100430000	COAX KX 21 A	* COAX KX 21 A	FILECA	0
Z1	1100530000	FIL.NU.ETAME.6/10	* TINNED BARE THREAD 6/10	ELECTROFIL	0
Z1	1269050700	CI 1 GENERATION 2230A	* PC 1 GENERATION 2230A	K996905.....TM	1
Z1	1269950000	CI SUPPORT QUARTZ 1'GENE 2200A	* PC BASE QUARTZ 1'GENERAT 2200A	A996995	1
Z1	1300600000	SOUPLISSO 1X1.2 COUL. NATUREL	* SPAGHETTI 1X1.2 GRAY COLORED	HABIA	0
Z1	1400109900	POINT TEST	* TEST POINT	C940850	12
Z1	1900200000	EXTRACTEUR DE CARTE'ELEVATEUR'	* BOARD EXTRACTOR 'LIFTER'	TRELEC	2
Z4	4900250000	ENTRETOISE T018-019D	* SPACER T018-019D	JERMYN	4
Z5	5100060000	SUPPORT DE QUARTZ REF SQ2Z VFA	* CRYSTAL SUPPORT REF SQ2Z VFA	UMD	1
Z5	5100090000	CLIPS POUR QUARTZ SQ	* CLIPS FOR CRYSTAL SQ	UMD	1
Z5	5400050000	CALE ISOLANTE NEOSID POUR CI	* NEOSID INSULATING QUOIN FOR PC	-940008	2
Z6	6130121000	LAD 2 X10 CYLINDRIQUE FENDUE	* LAD 2 X10 CYLINDRIQUE FENDUE	SAGIC	1
Z6	6200020000	ECROU H M2 U NF E27-411-5 INOX	* NUT H M2 U NF E27-411-5 INOX	BD	1
Z6	6300031000	3.2X 7X 1 PLATE INOX	* 3.2X 7X 1 FLAT INOX	BD	1
Z6	6301020000	DI 2 EVENTAIL NFE 27-618 INOX	* STEEL 2 FAN NFE 27-618 INOX	BD	1
Z6	6400040000	RIVET D 3 L 5 REF 3050	* RIVET D 3 L 5 REF 3050	MFOM	1
Z6	6400280000	PLOT A FOURCHE SOUDE . BFMQ13C	* SOLDERED FORK CONTACT BFMQ13C	COMATEL	2
Z6	6400510000	EQUERRE 10X10 LARG 10 EP 1	* ANGLEBRACKET10X10 WIDTH10 EP 1	A943051	1
Z6	6400530000	OEUILLER LAITON N° 2070	* FIXING EYELET BRASS .. N° 2070	MFOM	2
Z6	6400710000	BUS-BARRE PAS 12.7	* BUS-BAR STEP 12.7	SEEM	0
Z8	8000290000	BLINDAGE POUR NEOSID	* SHIELDING FOR NEOSID	B940048	1

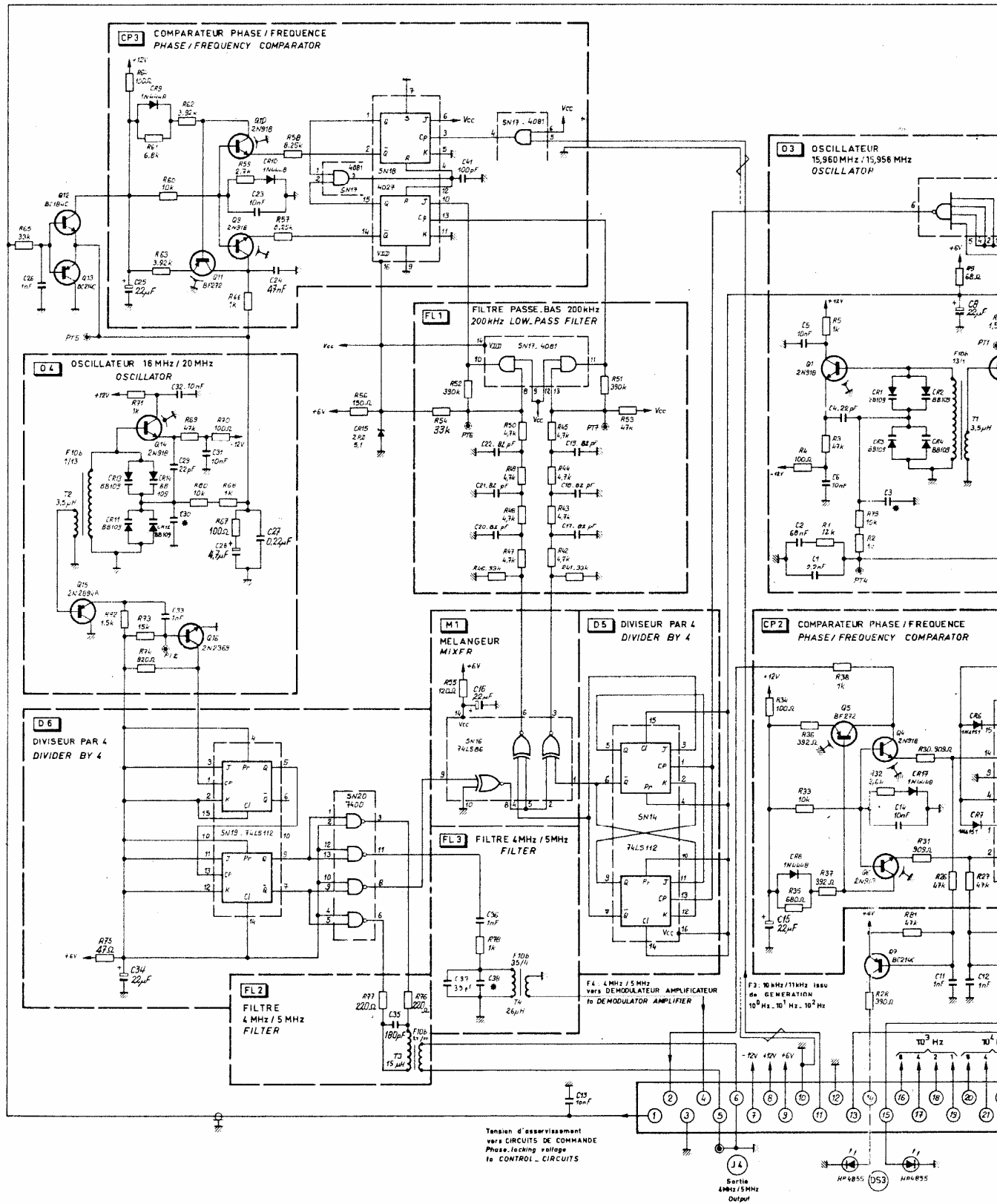

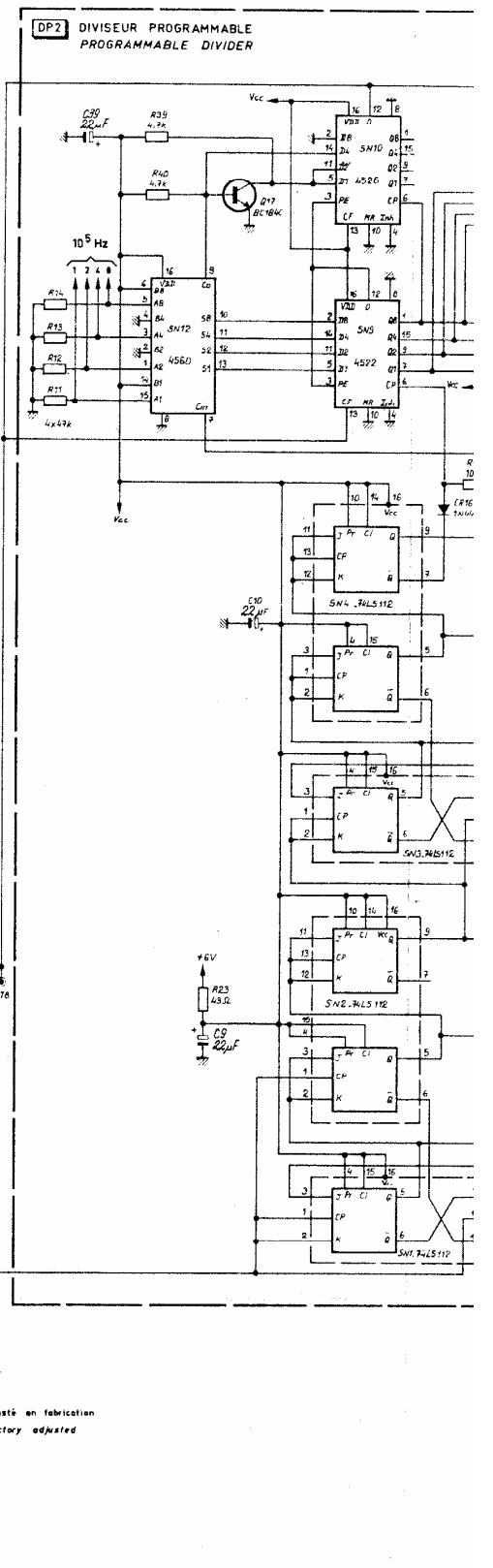
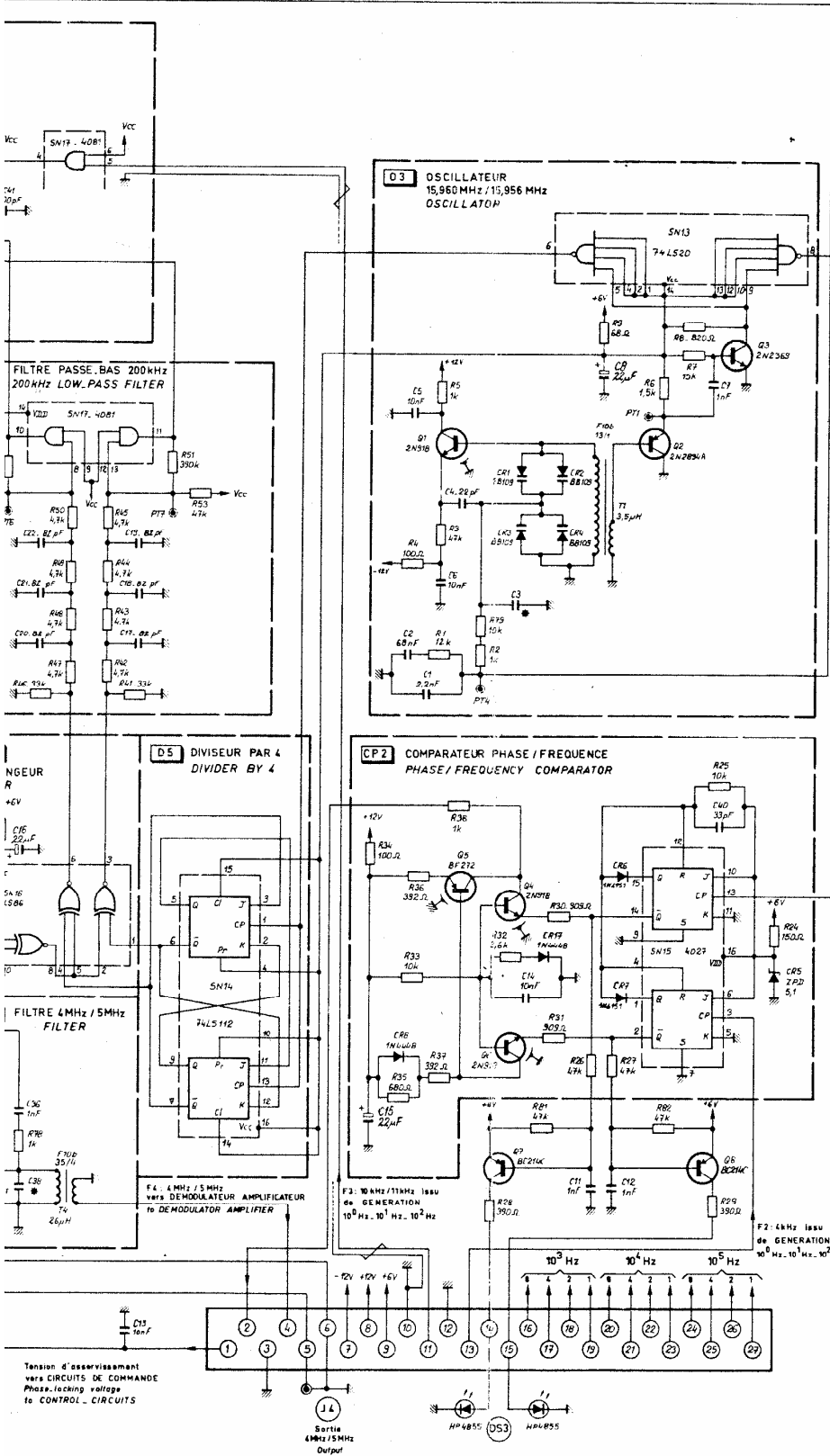

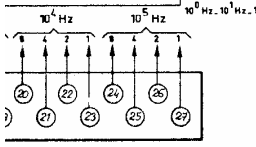
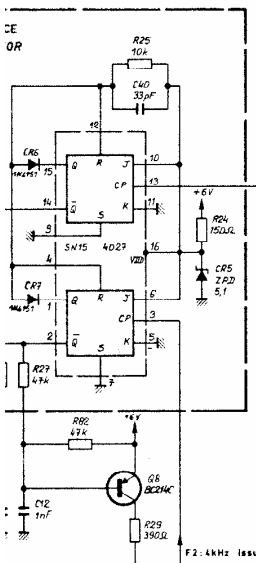
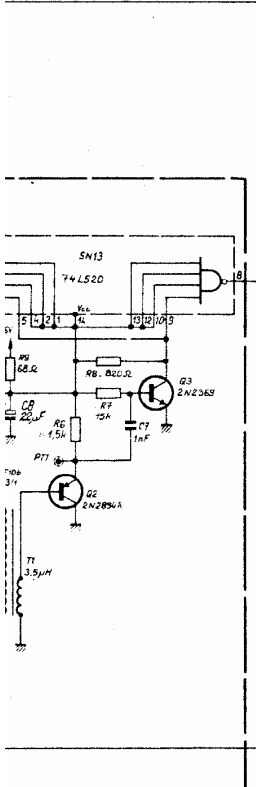

**DP2 DIVISEUR PROGRAMMABLE
PROGRAMMABLE DIVIDER**

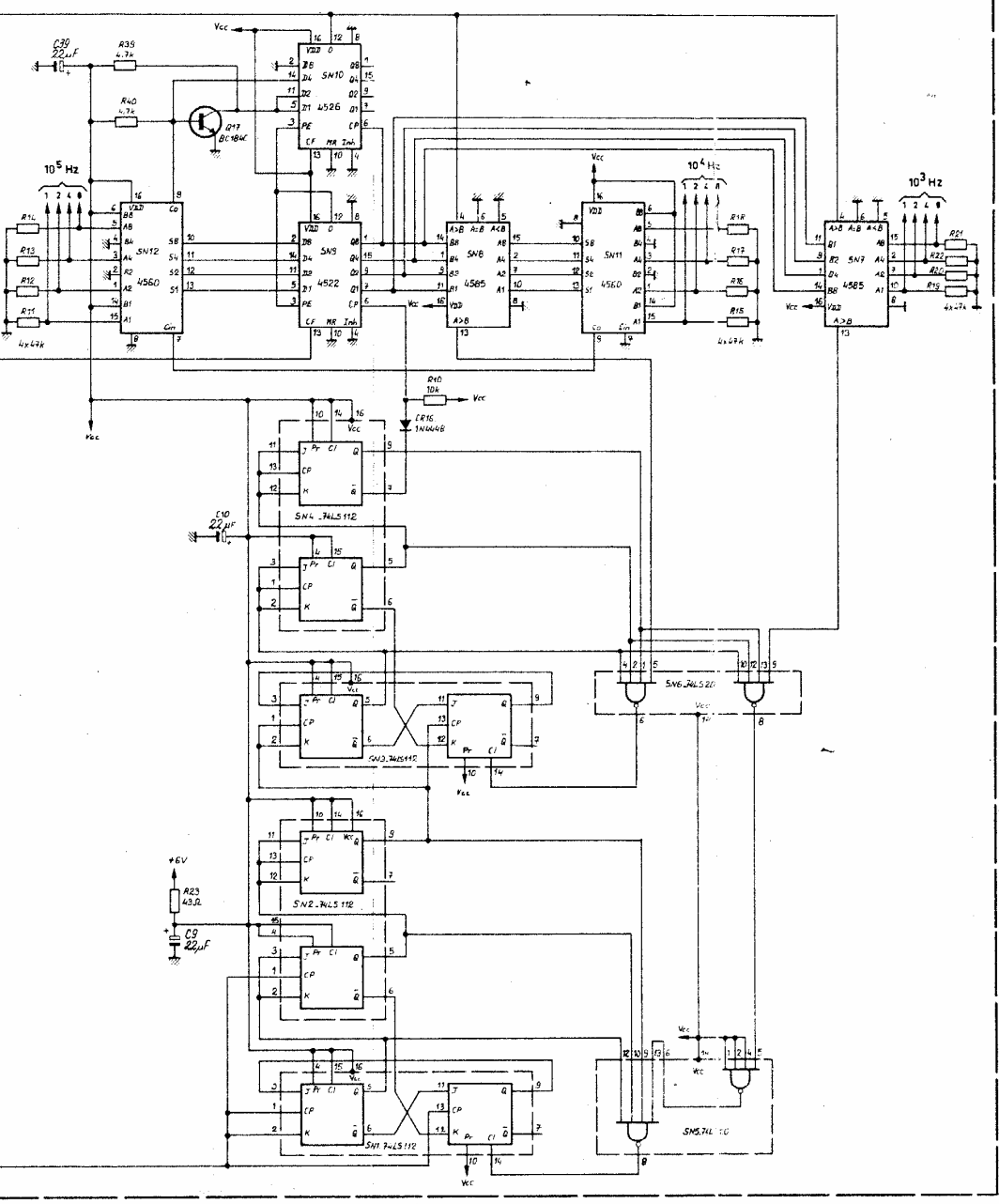

* Ajusté en fabrication
Factory adjusted

Ce document ne peut être communiqué ou reproduit sans autorisation		edrat électronique	DATE: JUILLET 1978
ETUDE	DESSIN	VERIFIE	2230 A
ACORT	H.V.		GENERATION 10 ³ Hz. 10 ⁴ Hz. 10 ⁵ Hz
		PAGE: 1 / 1	
		976906E	

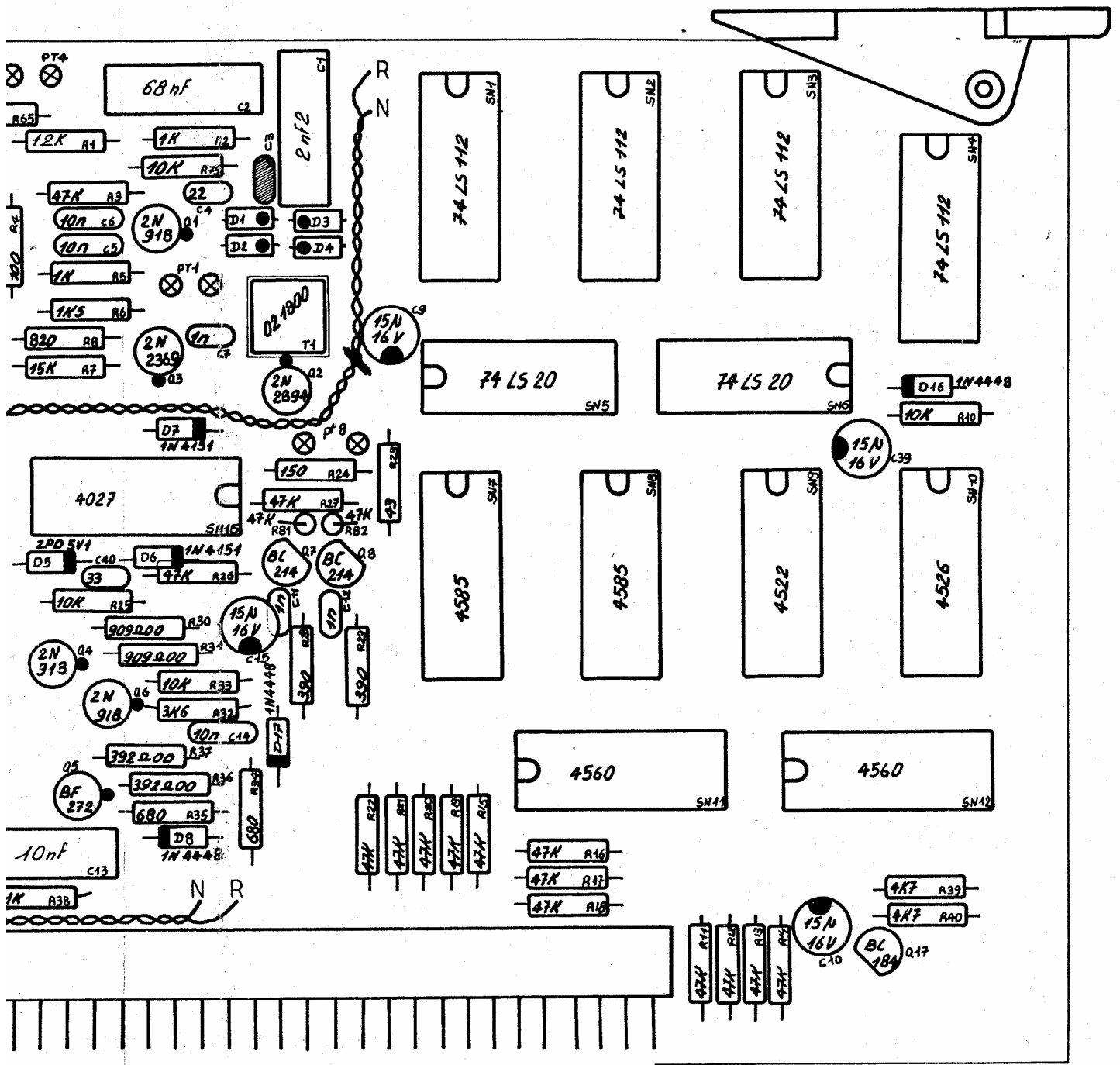

REPERE INDEXE	REF. ADRET PART NUMBER	DESCRIPTION	PART DESCRIPTION	FOURNISSEUR/PLAN SUPPLIER/DRAWING	QTE QTY
B -001	1427011600	TM 27 MCIG	TM 27 MCIG	MALE TRELLEC	1
C -001	3232220000	2200PF 10(10X400V)222236855222	2200PF 10(10X400V)222236855222	COGECO	1
C -002	3233680000	68NF 10(10X250V)222236845368	68NF 10(10X250V)222236845368	COGECO	1
C -003	3100000000	CONDENS CERAMIQUE A AJUSTER	CERAMIC CAPACITORS TO ADJUST	ADRET	1
C -004	3120002200	22PF 2,5 'K' 2222 680 10 229	22PF 2,5 'K' 2222 680 10 229	COGECO	1
C -005	3150031000	10NF 5,08 63V GOX 767 14	10NF 5,08 63V GOX 767 14	LCC	1
C -006	3150031000	10NF 5,08 63V GOX 767 14	10NF 5,08 63V GOX 767 14	LCC	1
C -007	3120021000	1 NF 2,5 2222 630 51 102	1 NF 2,5 2222 630 51 102	COGECO	1
C -008	3700180000	22MF/16V 5,08 ... STAND L TAG	22MF/16V 5,08 ... STAND L TAG	STC	1
C -009	3700180000	22MF/16V 5,08 ... STAND L TAG	22MF/16V 5,08 ... STAND L TAG	STC	1
C -010	3700180000	22MF/16V 5,08 ... STAND L TAG	22MF/16V 5,08 ... STAND L TAG	STC	1
C -011	3120021000	1 NF 2,5 2222 630 51 102	1 NF 2,5 2222 630 51 102	COGECO	1
C -012	3120021000	1 NF 2,5 2222 630 51 102	1 NF 2,5 2222 630 51 102	COGECO	1
C -013	3233100000	10NF 10(10X400V)222236855103	10NF 10(10X400V)222236855103	COGECO	1
C -014	3150031000	10NF 5,08 63V GOX 767 14	10NF 5,08 63V GOX 767 14	LCC	1
C -015	3700180000	22MF/16V 5,08 ... STAND L TAG	22MF/16V 5,08 ... STAND L TAG	STC	1
C -016	3700180000	22MF/16V 5,08 ... STAND L TAG	22MF/16V 5,08 ... STAND L TAG	STC	1
C -017	3120008200	82PF 2,5 2222 680 10 829	82PF 2,5 2222 680 10 829	COGECO	1
C -018	3120008200	82PF 2,5 2222 680 10 829	82PF 2,5 2222 680 10 829	COGECO	1
C -019	3120008200	82PF 2,5 2222 680 10 829	82PF 2,5 2222 680 10 829	COGECO	1
C -020	3120008200	82PF 2,5 2222 680 10 829	82PF 2,5 2222 680 10 829	COGECO	1
C -021	3120008200	82PF 2,5 2222 680 10 829	82PF 2,5 2222 680 10 829	COGECO	1
C -022	3120008200	82PF 2,5 2222 680 10 829	82PF 2,5 2222 680 10 829	COGECO	1
C -023	3150031000	10NF 5,08 63V GOX 767 14	10NF 5,08 63V GOX 767 14	LCC	1
C -024	3233470000	47NF 10(10X250V)222236845473	47NF 10(10X250V)222236845473	COGECO	1
C -025	3700180000	22MF/16V 5,08 ... STAND L TAG	22MF/16V 5,08 ... STAND L TAG	STC	1
C -026	3120021000	1 NF 2,5 2222 630 51 102	1 NF 2,5 2222 630 51 102	COGECO	1
C -027	3224220200	0,22MF 10,2 10X 40V CKM501	0,22MF 10,2 10X 40V CKM501	EUROFARAD	1
C -028	3700080000	4,7MF/10V L9 20% CTS13	4,7MF/10V L9 20% CTS13	SPRAGUE	1
C -029	3120002200	22PF 2,5 'K' 2222 680 10 229	22PF 2,5 'K' 2222 680 10 229	COGECO	1
C -030	3100000000	CONDENS CERAMIQUE A AJUSTER	CERAMIC CAPACITORS TO ADJUST	ADRET	1
C -031	3150031000	10NF 5,08 63V GOX 767 14	10NF 5,08 63V GOX 767 14	LCC	1
C -032	3150031000	10NF 5,08 63V GOX 767 14	10NF 5,08 63V GOX 767 14	LCC	1
C -033	3120021000	1 NF 2,5 2222 630 51 102	1 NF 2,5 2222 630 51 102	COGECO	1
C -034	3700180000	22MF/16V 5,08 ... STAND L TAG	22MF/16V 5,08 ... STAND L TAG	STC	1
C -035	3120011800	180PF 2,5 'N18' 2222 680 58 181	180PF 2,5 'N18' 2222 680 58 181	COGECO	1
C -036	3120021000	1 NF 2,5 2222 630 51 102	1 NF 2,5 2222 630 51 102	COGECO	1
C -037	3120003900	39PF 2,5 2222 680 10 399	39PF 2,5 2222 680 10 399	COGECO	1
C -038	3100000000	CONDENS CERAMIQUE A AJUSTER	CERAMIC CAPACITORS TO ADJUST	ADRET	1
C -039	3700180000	22MF/16V 5,08 ... STAND L TAG	22MF/16V 5,08 ... STAND L TAG	STC	1
C -040	3120003300	33PF 2,5 2222 680 10 339	33PF 2,5 2222 680 10 339	COGECO	1
C -041	3120011000	100PF 2,5 'N10' 2222 680 58 101	100PF 2,5 'N10' 2222 680 58 101	COGECO	1
D -001	0206520000	00 8XBB 409 D1&D4&D11&D14 2230	00 8XBB 409 D1&D4&D11&D14 2230	ADRET 8/SACHET	1
D -005	4600030000	ZPD5,1	ZPD5,1	ITT	1
D -006	4500020000	1N4151	1N4151	FU'ITT'	1
D -007	4500020000	1N4151	1N4151	FU'ITT'	1
D -008	4500310000	1 N 4448	1 N 4448	ITT	1
D -009	4500310000	1 N 4448	1 N 4448	ITT	1
D -010	4500310000	1 N 4448	1 N 4448	ITT	1
D -015	4600030000	ZPD5,1	ZPD5,1	ITT	1
D -016	4500310000	1 N 4448	1 N 4448	ITT	1
D -017	4500310000	1 N 4448	1 N 4448	ITT	1
Q -001	4300040000	2 N 918	2 N 918	SGS	1
Q -002	4300070000	2N2894	2N2894	MOTOROLA	1
Q -003	4300050000	2N2369 A	2N2369 A	MOTOROLA	1
Q -004	4300040000	2 N 918	2 N 918	SGS	1
Q -005	4300610000	BF 506	BF 506	MOTOROLA	1
Q -006	4300040000	2 N 918	2 N 918	SGS	1
Q -007	4300110000	BC560C /416C/415C/559C(BC214C)	BC560C /413C/415C/559C(BC214C)	RTC	1
Q -008	4300110000	BC560C /416C/415C/559C(BC214C)	BC560C /413C/415C/559C(BC214C)	RTC	1
Q -009	4300040000	2 N 918	2 N 918	SGS	1
Q -010	4300040000	2 N 918	2 N 918	SGS	1
Q -011	4300610000	BF 506	BF 506	MOTOROLA	1
Q -012	4300190000	BC550C /414C/413C/549C(BC184C)	BC550C /414C/413C/549C(BC184C)	RTC	1
Q -013	4300110000	BC560C /416C/415C/559C(BC214C)	BC560C /413C/415C/559C(BC214C)	RTC	1
Q -014	4300040000	2 N 918	2 N 918	SGS	1
Q -015	4300070000	2N2894	2N2894	MOTOROLA	1
Q -016	4300050000	2N2369 A	2N2369 A	MOTOROLA	1
Q -017	4300190000	BC550C /414C/413C/549C(BC184C)	BC550C /414C/413C/549C(BC184C)	RTC	1
R -001	2210031200	12K 5% N4	12K 5% N4	SOUCOR	1
R -002	2210021000	1K0 5% N4	1K0 5% N4	SOUCOR	1
R -003	2210034700	47K 5% N4	47K 5% N4	SOUCOR	1
R -004	2210011000	100R 5% N4	100R 5% N4	SOUCOR	1
R -005	2210021000	1K0 5% N4	1K0 5% N4	SOUCOR	1
R -006	2210021500	1K5 5% N4	1K5 5% N4	SOUCOR	1
R -007	2210031500	15K 5% N4	15K 5% N4	SOUCOR	1
R -008	2210018200	820R 5% N4	820R 5% N4	SOUCOR	1
R -009	2210006800	68R 5% N4	68R 5% N4	SOUCOR	1
R -010	2210031000	10K 5% N4	10K 5% N4	SOUCOR	1

REPERE INDEXE	REF. ADRET PART NUMBER	DESCRIPTION	PART DESCRIPTION	FOURNISSEUR/PLAN SUPPLIER/DRAWING	QTE QTY
R -011	2210034700	47K	5X N4 * 47K	5X N4 SOUCOR	1
R -012	2210034700	47K	5X N4 * 47K	5X N4 SOUCOR	1
R -013	2210034700	47K	5X N4 * 47K	5X N4 SOUCOR	1
R -014	2210034700	47K	5X N4 * 47K	5X N4 SOUCOR	1
R -015	2210034700	47K	5X N4 * 47K	5X N4 SOUCOR	1
R -016	2210034700	47K	5X N4 * 47K	5X N4 SOUCOR	1
R -017	2210034700	47K	5X N4 * 47K	5X N4 SOUCOR	1
R -018	2210034700	47K	5X N4 * 47K	5X N4 SOUCOR	1
R -019	2210034700	47K	5X N4 * 47K	5X N4 SOUCOR	1
R -020	2210034700	47K	5X N4 * 47K	5X N4 SOUCOR	1
R -021	2210034700	47K	5X N4 * 47K	5X N4 SOUCOR	1
R -022	2210034700	47K	5X N4 * 47K	5X N4 SOUCOR	1
R -023	221004300	43R	5X N4 * 43R	5X N4 SOUCOR	1
R -024	2210011500	150R	5X N4 * 150R	5X N4 SOUCOR	1
R -025	2210031000	10K	5X N4 * 10K	5X N4 SOUCOR	1
R -026	2210034700	47K	5X N4 * 47K	5X N4 SOUCOR	1
R -027	2210034700	47K	5X N4 * 47K	5X N4 SOUCOR	1
R -028	2210013900	390R	5X N4 * 390R	5X N4 SOUCOR	1
R -029	2210013900	390R	5X N4 * 390R	5X N4 SOUCOR	1
R -030	2500090900	909R * 1X 0,3 W	SMA207 * 909R * 1X 0,3 W	SMA207 DRALORIC	1
R -031	2500090900	909R * 1X 0,3 W	SMA207 * 909R * 1X 0,3 W	SMA207 DRALORIC	1
R -032	2210023600	3K6	5X N4 * 3K6	5X N4 SOUCOR	1
R -033	2210031000	10K	5X N4 * 10K	5X N4 SOUCOR	1
R -034	2210016800	680R	5X N4 * 680R	5X N4 SOUCOR	1
R -035	2210011200	120R	5X N4 * 120R	5X N4 SOUCOR	1
R -035	2210016800	680R	5X N4 * 680R	5X N4 SOUCOR	1
R -036	2500039200	392R * 1X 0,3 W	SMA207 * 392R * 1X 0,3 W	SMA207 DRALORIC	1
R -037	2500039200	392R * 1X 0,3 W	SMA207 * 392R * 1X 0,3 W	SMA207 DRALORIC	1
R -038	2210021000	1K0	5X N4 * 1K0	5X N4 SOUCOR	1
R -039	2210024700	4K7	5X N4 * 4K7	5X N4 SOUCOR	1
R -040	2210024700	4K7	5X N4 * 4K7	5X N4 SOUCOR	1
R -041	2210023300	3K3	5X N4 * 3K3	5X N4 SOUCOR	1
R -042	2210024700	4K7	5X N4 * 4K7	5X N4 SOUCOR	1
R -043	2210024700	4K7	5X N4 * 4K7	5X N4 SOUCOR	1
R -044	2210024700	4K7	5X N4 * 4K7	5X N4 SOUCOR	1
R -045	2210024700	4K7	5X N4 * 4K7	5X N4 SOUCOR	1
R -046	2210023300	3K3	5X N4 * 3K3	5X N4 SOUCOR	1
R -047	2210024700	4K7	5X N4 * 4K7	5X N4 SOUCOR	1
R -048	2210024700	4K7	5X N4 * 4K7	5X N4 SOUCOR	1
R -049	2210024700	4K7	5X N4 * 4K7	5X N4 SOUCOR	1
R -050	2210024700	4K7	5X N4 * 4K7	5X N4 SOUCOR	1
R -051	2210043900	390K	5X N4 * 390K	5X N4 SOUCOR	1
R -052	2210043900	390K	5X N4 * 390K	5X N4 SOUCOR	1
R -053	2210033300	33K	5X N4 * 33K	5X N4 SOUCOR	1
R -054	2210033300	33K	5X N4 * 33K	5X N4 SOUCOR	1
R -056	2210011500	150R	5X N4 * 150R	5X N4 SOUCOR	1
R -057	2500182500	8K25 * 1X 0,3 W	SMA207 * 8K25 * 1X 0,3 W	SMA207 DRALORIC	1
R -058	2500182500	8K25 * 1X 0,3 W	SMA207 * 8K25 * 1X 0,3 W	SMA207 DRALORIC	1
R -059	2210022700	2K7	5X N4 * 2K7	5X N4 SOUCOR	1
R -060	2210031000	10K	5X N4 * 10K	5X N4 SOUCOR	1
R -061	2210026800	6K8	5X N4 * 6K8	5X N4 SOUCOR	1
R -062	2500139200	3K92 * 1X 0,3 W	SMA207 * 3K92 * 1X 0,3 W	SMA207 DRALORIC	1
R -063	2500139200	3K92 * 1X 0,3 W	SMA207 * 3K92 * 1X 0,3 W	SMA207 DRALORIC	1
R -064	2210011000	100R	5X N4 * 100R	5X N4 SOUCOR	1
R -065	2210033300	33K	5X N4 * 33K	5X N4 SOUCOR	1
R -066	2210021000	1K0	5X N4 * 1K0	5X N4 SOUCOR	1
R -067	2210011000	100R	5X N4 * 100R	5X N4 SOUCOR	1
R -068	2210021000	1K0	5X N4 * 1K0	5X N4 SOUCOR	1
R -069	2210034700	47K	5X N4 * 47K	5X N4 SOUCOR	1
R -070	2210011000	100R	5X N4 * 100R	5X N4 SOUCOR	1
R -071	2210021000	1K0	5X N4 * 1K0	5X N4 SOUCOR	1
R -072	2210021500	1K5	5X N4 * 1K5	5X N4 SOUCOR	1
R -073	2210031500	15K	5X N4 * 15K	5X N4 SOUCOR	1
R -074	2210018200	820R	5X N4 * 820R	5X N4 SOUCOR	1
R -075	2210004700	47R	5X N4 * 47R	5X N4 SOUCOR	1
R -076	2210012200	220R	5X N4 * 220R	5X N4 SOUCOR	1
R -077	2210012200	220R	5X N4 * 220R	5X N4 SOUCOR	1
R -078	2210021000	1K0	5X N4 * 1K0	5X N4 SOUCOR	1
R -079	2210031000	10K	5X N4 * 10K	5X N4 SOUCOR	1
R -080	2210031000	10K	5X N4 * 10K	5X N4 SOUCOR	1
R -081	2200034700	47K	5X N4 * 47K	5X N4 SOUCOR	1
R -082	2200034700	47K	5X N4 * 47K	5X N4 SOUCOR	1
SN -001	4157411200	SN 74 LS 112 N	SN 74 LS 112 N	'FU' TEXAS	1
SN -002	4157411200	SN 74 LS 112 N	SN 74 LS 112 N	'FU' TEXAS	1
SN -003	4157411200	SN 74 LS 112 N	SN 74 LS 112 N	'FU' TEXAS	1
SN -004	4157411200	SN 74 LS 112 N	SN 74 LS 112 N	'FU' TEXAS	1
SN -005	4150742000	SN 74 LS 20 N 3	SN 74 LS 20 N 3	TEXAS	1
SN -006	4150742000	SN 74 LS 20 N 3	SN 74 LS 20 N 3	TEXAS	1
SN -007	4160458500	C-MOS 4585	C-MOS 4585	'FU' RTC	1

REPERE INDEXE	REF. ADRET PART NUMBER	DESCRIPTION	PART DESCRIPTION	FOURNISSEUR/PLAN SUPPLIER/DRAWING	QTE QTY
SN -008	4160458500	C-MOS 4585	* C-MOS 4585	'FU' RTC	1
SN -009	4160452200	C-MOS 4522	* C-MOS 4522	RTC	1
SN -010	4160452600	C-MOS 4526	* C-MOS 4526	RTC	1
SN -011	4160456000	C-MOS 4560	* C-MOS 4560	MC 14560 BCP MOTOROLA	1
SN -012	4160456000	C-MOS 4560	* C-MOS 4560	MC 14560 BCP MOTOROLA	1
SN -013	4150742000	SN 74 LS 20 N 3	* SN 74 LS 20 N 3	TEXAS	1
SN -014	4157411200	SN 74 LS 112 N	* SN 74 LS 112 N	'FU' TEXAS	1
SN -015	4160402700	C-MOS 4027	* C-MOS 4027	RTC	1
SN -016	4150748600	SN 74 LS 86 N 3	* SN 74 LS 86 N 3	TEXAS	1
SN -017	4160408100	C-MOS 4081	* C-MOS 4081	RTC	1
SN -018	4160402700	C-MOS 4027	* C-MOS 4027	RTC	1
SN -019	4157411200	SN 74 LS 112 N	* SN 74 LS 112 N	'FU' TEXAS	1
SN -020	4110740000	SN 7400 N	* SN 7400 N	TEXAS	1
T -001	0218000000	01 F108 13X1	* 01 F108 13X1 TURNS	2230A Z94 F108.....14	1
T -002	0218000000	01 F108 13X1	* 01 F108 13X1 TURNS	2230A Z94 F108.....14	1
T -003	0216650000	00 F108 18X6 SPIRES	* 00 F108 18X6 TURNS	4101 Z94 F108.....24	1
T -004	0218020000	00 F108 35X4	* 00 F108 35X4 TURNS	2200A Z94 F108.....39	1
Z0	0206750000	00 ETIQUETTE 6906	* 00 LABEL 6906	2230A 942375.....	1
Z1	1100010000	FIL NOIR	* BLACK THREAD	KY30-04 FILECA	0
Z1	1100030000	FIL ROUGE	* RED THREAD	KY30-04 FILECA	0
Z1	1100430000	COAX KX 21 A	* COAX KX 21 A	FILECA	0
Z1	1100520000	FIL NU ETAME 4/10	* TINNED BARE THREAD 4/10	ELECTROFIL	0
Z1	1269060500	CI 2'GENERATION	* PC 2'GENERATION	2230A H996906	1
Z1	1300600000	SOUPLISSO 1X1,2 COUL. NATUREL	* SPAGHETTI 1X1.2 GRAY COLORED	HABIA	0
Z1	1400109900	POINT TEST	* TEST POINT	C940850	13
Z1	1900200000	EXTRACTEUR DE CARTE 'ELEVATEUR'	* BOARD EXTRACTOR 'LIFTER'	TRELEC	2
Z4	4900250000	ENTRETOISE T018-019D	* SPACER T018-019D	JERMYN	9
Z5	5400050000	CALE ISOLANTE NEOSID POUR CI	* NEOSID INSULATING QUOIN FOR PC	-940008	4
Z6	6400280000	PLOT A FOURCHE SOUDE . BFMQ13C	* SOLDERED FORK CONTACT BFMQ13C	COMATEL	2
Z6	6400530000	OEILLET LAITON .. N° 2070	* FIXING EYELET BRASS .. N° 2070	MCOM	2
Z8	8000290000	BLINDAGE POUR NEOSID	* SHIELDING FOR NEOSID	8940048	2

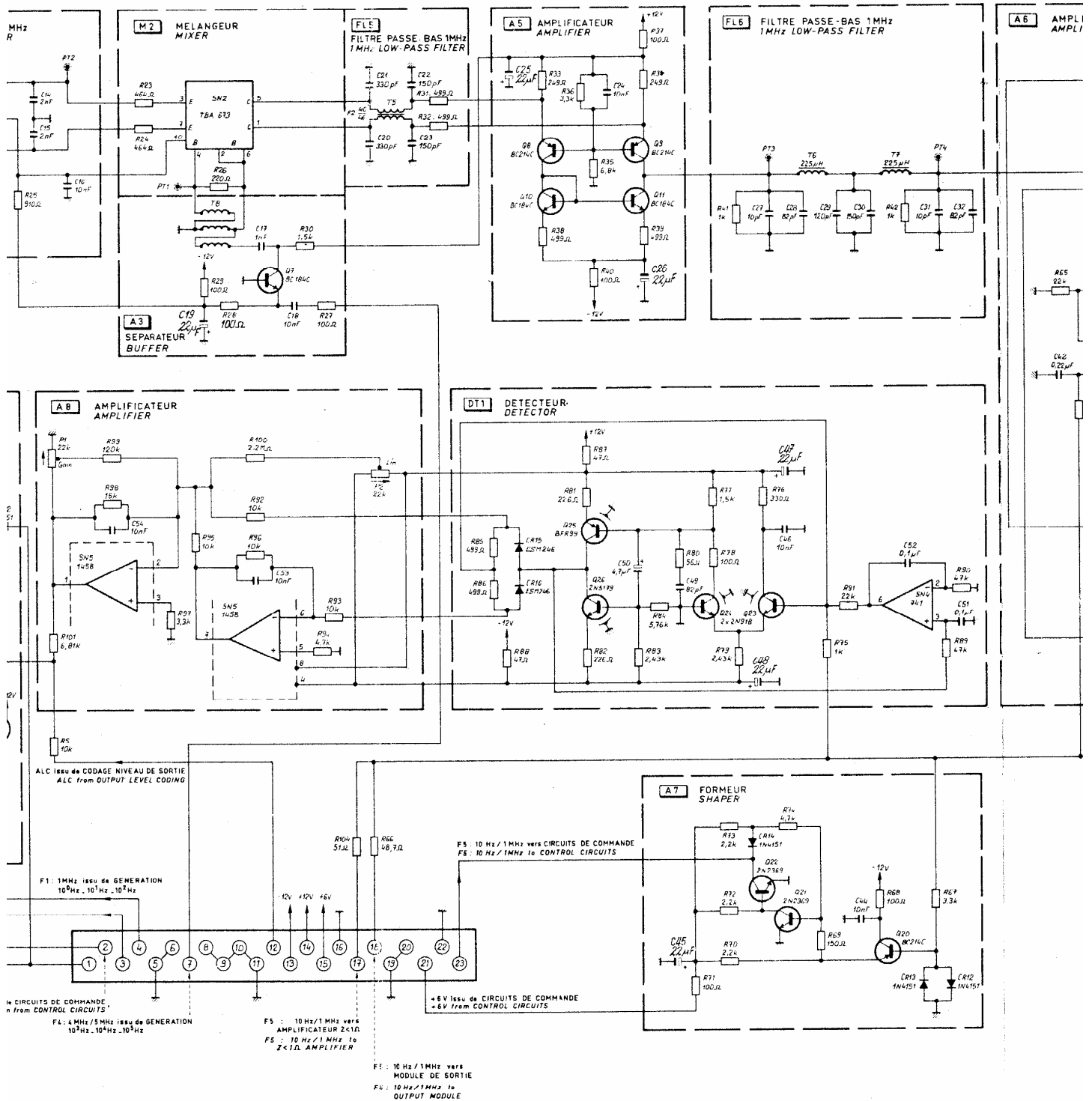

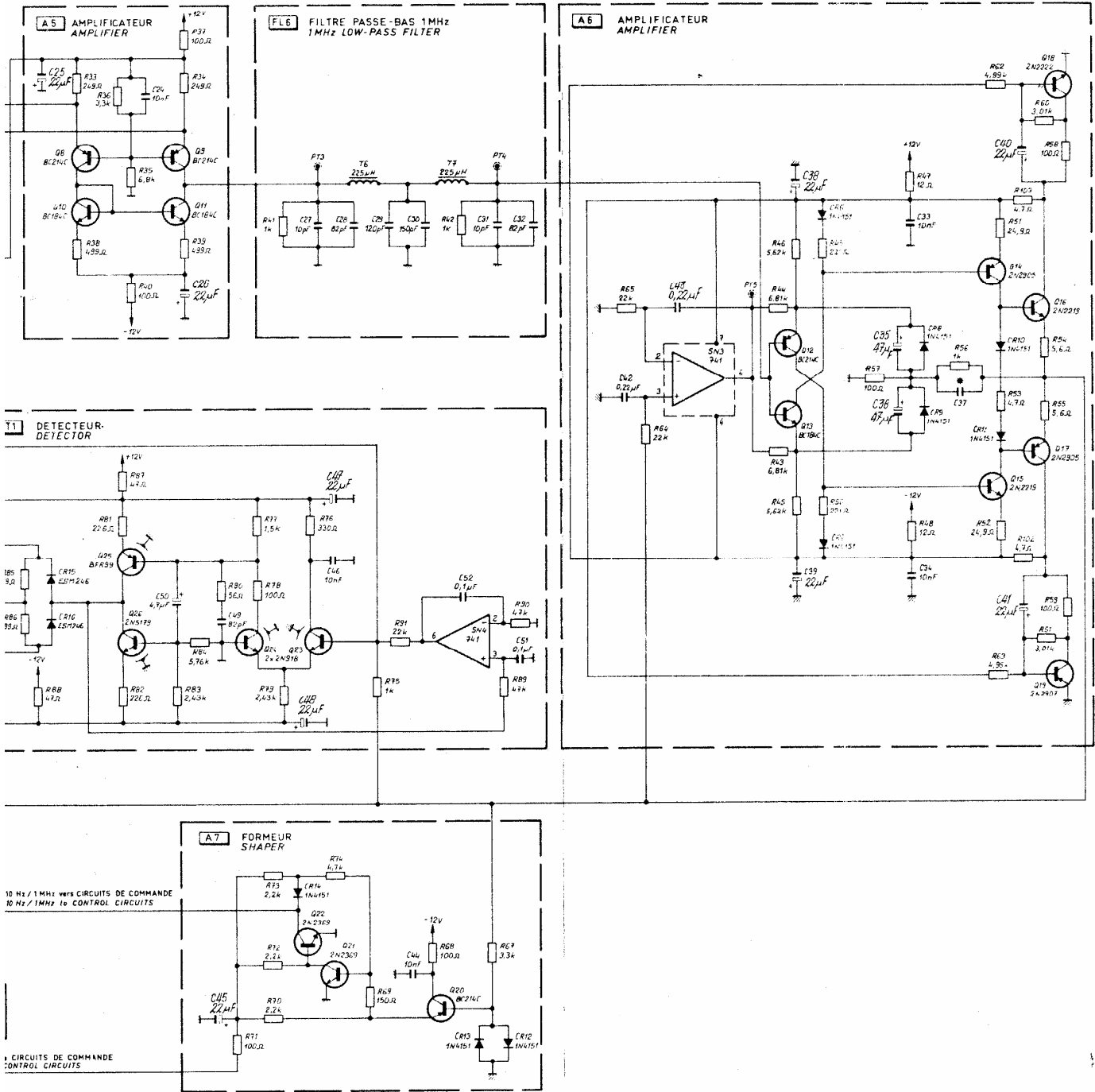

REPERE INDEXE	REF. PART	ADRET NUMBER	DESCRIPTION	PART DESCRIPTION	FOURNISSEUR/PLAN SUPPLIER/DRAWING	QTE QTY	
B -001	1423000400	TM 23	MCIG	MALE CARTE	TM 23 MCIG	MALE TREC	1
C -001	3700180000	22MMF/16V 5,08	STAND L TAG	22MMF/16V 5,08	STAND L TAG	STC	1
C -002	3234100100	0,1MMF 7,5 20% 100V	MKS4	0,1MMF 7,5 20% 100V	MKS4	WIMA	1
C -003	3150031000	10NF 5,08 63V	GOX 767 14	10NF 5,08 63V	GOX 767 14	LCC	1
C -004	3150031000	10NF 5,08 63V	GOX 767 14	10NF 5,08 63V	GOX 767 14	LCC	1
C -005	3120021000	1 NF 2,5	2222 630 51 102	1 NF 2,5	2222 630 51 102	COGECO	1
C -006	3120013300	330PF 2,5 N33	2222 680 58 331	330PF 2,5 N33	2222 680 58 331	COGECO	1
C -007	3120013300	330PF 2,5 N33	2222 680 58 331	330PF 2,5 N33	2222 680 58 331	COGECO	1
C -008	3150031000	10NF 5,08 63V	GOX 767 14	10NF 5,08 63V	GOX 767 14	LCC	1
C -009	3150031000	10NF 5,08 63V	GOX 767 14	10NF 5,08 63V	GOX 767 14	LCC	1
C -010	3150031000	10NF 5,08 63V	GOX 767 14	10NF 5,08 63V	GOX 767 14	LCC	1
C -011	3700180000	22MMF/16V 5,08	STAND L TAG	22MMF/16V 5,08	STAND L TAG	STC	1
C -012	3300249000	249PF 7,6 2% 250V	59SP	249PF 7,6 2% 250V	59SP	GAM	1
C -013	3120001500	15PF 2,5 H	2222 680 10 159	15PF 2,5 H	2222 680 10 159	COGECO	1
C -014	3301200100	2000PF 7,62 5% 250V	59 SP	2000PF 7,62 5% 250V	59 SP	GAM	1
C -015	3301200100	2000PF 7,62 5% 250V	59 SP	2000PF 7,62 5% 250V	59 SP	GAM	1
C -016	3150031000	10NF 5,08 63V	GOX 767 14	10NF 5,08 63V	GOX 767 14	LCC	1
C -017	3120021000	1 NF 2,5	2222 630 51 102	1 NF 2,5	2222 630 51 102	COGECO	1
C -018	3150031000	10NF 5,08 63V	GOX 767 14	10NF 5,08 63V	GOX 767 14	LCC	1
C -019	3700180000	22MMF/16V 5,08	STAND L TAG	22MMF/16V 5,08	STAND L TAG	STC	1
C -020	3120013300	330PF 2,5 N33	2222 680 58 331	330PF 2,5 N33	2222 680 58 331	COGECO	1
C -021	3120013300	330PF 2,5 N33	2222 680 58 331	330PF 2,5 N33	2222 680 58 331	COGECO	1
C -022	3120011500	150PF 2,5 N15	2222 680 58 151	150PF 2,5 N15	2222 680 58 151	COGECO	1
C -023	3120011500	150PF 2,5 N15	2222 680 58 151	150PF 2,5 N15	2222 680 58 151	COGECO	1
C -024	3150031000	10NF 5,08 63V	GOX 767 14	10NF 5,08 63V	GOX 767 14	LCC	1
C -025	3700180000	22MMF/16V 5,08	STAND L TAG	22MMF/16V 5,08	STAND L TAG	STC	1
C -026	3700180000	22MMF/16V 5,08	STAND L TAG	22MMF/16V 5,08	STAND L TAG	STC	1
C -027	3120001000	10PF 2,5 F	2222 680 10 109	10PF 2,5 F	2222 680 10 109	COGECO	1
C -028	3120008200	82PF 2,5	2222 680 10 829	82PF 2,5	2222 680 10 829	COGECO	1
C -029	3120011200	120PF 2,5 N12	2222 680 58 121	120PF 2,5 N12	2222 680 58 121	COGECO	1
C -030	3120011500	150PF 2,5 N15	2222 680 58 151	150PF 2,5 N15	2222 680 58 151	COGECO	1
C -031	3120001000	10PF 2,5 F	2222 680 10 109	10PF 2,5 F	2222 680 10 109	COGECO	1
C -032	3120008200	82PF 2,5	2222 680 10 829	82PF 2,5	2222 680 10 829	COGECO	1
C -033	3150031000	10NF 5,08 63V	GOX 767 14	10NF 5,08 63V	GOX 767 14	LCC	1
C -034	3150031000	10NF 5,08 63V	GOX 767 14	10NF 5,08 63V	GOX 767 14	LCC	1
C -035	3700250000	47MMF/6,3V 5,08	STAND L TAG	47MMF/6,3V 5,08	STAND L TAG	STC	1
C -036	3700250000	47MMF/6,3V 5,08	STAND L TAG	47MMF/6,3V 5,08	STAND L TAG	STC	1
C -037	3100000000	CONDENS CERAMIQUE	A AJUSTER	CERAMIC CAPACITORS	TO ADJUST	ADRET	1
C -038	3700180000	22MMF/16V 5,08	STAND L TAG	22MMF/16V 5,08	STAND L TAG	STC	1
C -039	3700180000	22MMF/16V 5,08	STAND L TAG	22MMF/16V 5,08	STAND L TAG	STC	1
C -040	3700180000	22MMF/16V 5,08	STAND L TAG	22MMF/16V 5,08	STAND L TAG	STC	1
C -041	3700180000	22MMF/16V 5,08	STAND L TAG	22MMF/16V 5,08	STAND L TAG	STC	1
C -042	3224220200	0,22MMF 10,2 10% 40V	CKM501	0,22MMF 10,2 10% 40V	CKM501	EUROFARAD	1
C -043	3224220200	0,22MMF 10,2 10% 40V	CKM501	0,22MMF 10,2 10% 40V	CKM501	EUROFARAD	1
C -044	3150031000	10NF 5,08 63V	GOX 767 14	10NF 5,08 63V	GOX 767 14	LCC	1
C -045	3700180000	22MMF/16V 5,08	STAND L TAG	22MMF/16V 5,08	STAND L TAG	STC	1
C -046	3150031000	10NF 5,08 63V	GOX 767 14	10NF 5,08 63V	GOX 767 14	LCC	1
C -047	3700180000	22MMF/16V 5,08	STAND L TAG	22MMF/16V 5,08	STAND L TAG	STC	1
C -048	3700180000	22MMF/16V 5,08	STAND L TAG	22MMF/16V 5,08	STAND L TAG	STC	1
C -049	3120008200	82PF 2,5	2222 680 10 829	82PF 2,5	2222 680 10 829	COGECO	1
C -050	3700100000	4,7MMF/35V 5,08	STAND L TAG	4,7MMF/35V 5,08	STAND L TAG	STC	1
C -051	3234100100	0,1MMF 7,5 20% 100V	MKS4	0,1MMF 7,5 20% 100V	MKS4	WIMA	1
C -052	3234100100	0,1MMF 7,5 20% 100V	MKS4	0,1MMF 7,5 20% 100V	MKS4	WIMA	1
C -053	3150031000	10NF 5,08 63V	GOX 767 14	10NF 5,08 63V	GOX 767 14	LCC	1
C -054	3150031000	10NF 5,08 63V	GOX 767 14	10NF 5,08 63V	GOX 767 14	LCC	1
D -001	4500020000	IN4151		IN4151		FU'ITT	1
D -002	4500020000	IN4151		IN4151		FU'ITT	1
D -003	4500020000	IN4151		IN4151		FU'ITT	1
D -004	4500020000	IN4151		IN4151		FU'ITT	1
D -005	4500020000	IN4151		IN4151		FU'ITT	1
D -006	4500020000	IN4151		IN4151		FU'ITT	1
D -007	4500020000	IN4151		IN4151		FU'ITT	1
D -008	4500020000	IN4151		IN4151		FU'ITT	1
D -009	4500020000	IN4151		IN4151		FU'ITT	1
D -010	4500020000	IN4151		IN4151		FU'ITT	1
D -011	4500020000	IN4151		IN4151		FU'ITT	1
D -012	4500020000	IN4151		IN4151		FU'ITT	1
D -013	4500020000	IN4151		IN4151		FU'ITT	1
D -014	4500020000	IN4151		IN4151		FU'ITT	1
D -015	4500540000	IN6263 D035	(EX ESM247&246)	IN6263	(SUBSTIT. ESM247&246)	RTC	1
D -016	4500540000	IN6263 D035	(EX ESM247&246)	IN6263	(SUBSTIT. ESM247&246)	RTC	1
P -001	2133220000	22K 3/4" 15T CERMET	43 P	22K 3/4" 15T CERMET	43 P	SPECTROL	1
P -002	2133220000	22K 3/4" 15T CERMET	43 P	22K 3/4" 15T CERMET	43 P	SPECTROL	1
Q -001	4300190000	BC550C /414C/413C/549C	(BC184C)	BC550C /414C/413C/549C	(BC184C)	RTC	1
Q -002	4300110000	BC560C /416C/415C/559C	(BC214C)	BC560C /413C/415C/559C	(BC214C)	RTC	1
Q -003	4300190000	BC550C /414C/413C/549C	(BC184C)	BC550C /414C/413C/549C	(BC184C)	RTC	1
Q -004	4300190000	BC550C /414C/413C/549C	(BC184C)	BC550C /414C/413C/549C	(BC184C)	RTC	1
Q -005	4300050000	2N2369 A		2N2369 A		MOTOROLA	1
Q -006	4300050000	2N2369 A		2N2369 A		MOTOROLA	1

REPERE INDEXE	REF. ADRET PART NUMBER	DESCRIPTION	PART DESCRIPTION	FOURNISSEUR/PLAN SUPPLIER/DRAWING	QTE QTY
Q	-007	4300190000 BC550C /414C/413C/549C(BC184C)	* BC550C /414C/413C/549C(BC184C)	RTC	1
Q	-008	4300110000 BC560C /416C/415C/559C(BC214C)	* BC560C /413C/415C/559C(BC214C)	RTC	1
Q	-009	4300110000 BC560C /416C/415C/559C(BC214C)	* BC560C /413C/415C/559C(BC214C)	RTC	1
Q	-010	4300190000 BC550C /414C/413C/549C(BC184C)	* BC550C /414C/413C/549C(BC184C)	RTC	1
Q	-011	4300190000 BC550C /414C/413C/549C(BC184C)	* BC550C /414C/413C/549C(BC184C)	RTC	1
Q	-012	4300110000 BC560C /416C/415C/559C(BC214C)	* BC560C /413C/415C/559C(BC214C)	RTC	1
Q	-013	4300190000 BC550C /414C/413C/549C(BC184C)	* BC550C /414C/413C/549C(BC184C)	RTC	1
Q	-014	4800080000 2N2905	* 2N2905	RTC	1
Q	-015	4800060000 2N2219	* 2N2219	RTC	1
Q	-016	4800060000 2N2219	* 2N2219	RTC	1
Q	-017	4800080000 2N2905	* 2N2905	RTC	1
Q	-018	4300580000 BC 337-25 TO 92 (2N2222)	* BC 337-25 TO 92 (2N2222)	ITT	1
Q	-019	4300570000 BC 327-25 TO 92 (2N2907)	* BC 327-25 TO 92 (2N2907)	ITT	1
Q	-020	4300110000 BC560C /416C/415C/559C(BC214C)	* BC560C /413C/415C/559C(BC214C)	RTC	1
Q	-021	4300050000 2N2369 A	* 2N2369 A	MOTOROLA	1
Q	-022	4300050000 2N2369 A	* 2N2369 A	MOTOROLA	1
Q	-023	4300040000 2 N 918	* 2 N 918	SGS	1
Q	-024	4300040000 2 N 918	* 2 N 918	SGS	1
Q	-025	4300130000 BFR 99	* BFR 99	MOTOROLA	1
Q	-026	4300720000 BFY 90	* BFY 90	RTC	1
R	-001	2210021000 1K0	5% N4 1K0	SOUCOR	1
R	-002	2210034700 47K	5% N4 47K	SOUCOR	1
R	-003	2210022700 2K7	5% N4 2K7	SOUCOR	1
R	-004	2210031000 10K	5% N4 10K	SOUCOR	1
R	-005	2500210000 10K0 * 1% 0,3 U SMA207	10K0 * 1% 0,3 U SMA207	DRALORIC	1
R	-006	2210031000 10K	5% N4 10K	SOUCOR	1
R	-007	2210031200 12K	5% N4 12K	SOUCOR	1
R	-008	2210022200 2K2	5% N4 2K2	SOUCOR	1
R	-009	2210031000 10K	5% N4 10K	SOUCOR	1
R	-010	2210041000 100K	5% N4 100K	SOUCOR	1
R	-011	2210022200 2K2	5% N4 2K2	SOUCOR	1
R	-012	2210022700 2K7	5% N4 2K7	SOUCOR	1
R	-013	2210023900 3K9	5% N4 3K9	SOUCOR	1
R	-014	2210011000 100R	5% N4 100R	SOUCOR	1
R	-015	2210011000 100R	5% N4 100R	SOUCOR	1
R	-016	2210014700 470R	5% N4 470R	SOUCOR	1
R	-017	2210022700 2K7	5% N4 2K7	SOUCOR	1
R	-018	2210022700 2K7	5% N4 2K7	SOUCOR	1
R	-019	2210022200 2K2	5% N4 2K2	SOUCOR	1
R	-020	2210031200 12K	5% N4 12K	SOUCOR	1
R	-021	2210011000 100R	5% N4 100R	SOUCOR	1
R	-022	2210024700 4K7	5% N4 4K7	SOUCOR	1
R	-023	2500046400 464R * 1% 0,3 U SMA207	464R * 1% 0,3 U SMA207	DRALORIC	1
R	-024	2500046400 464R * 1% 0,3 U SMA207	464R * 1% 0,3 U SMA207	DRALORIC	1
R	-025	2210019100 910R	5% N4 910R	SOUCOR	1
R	-026	2210012200 220R	5% N4 220R	SOUCOR	1
R	-027	2210011000 100R	5% N4 100R	SOUCOR	1
R	-028	2210022200 2K2	5% N4 2K2	SOUCOR	1
R	-029	2210011000 100R	5% N4 100R	SOUCOR	1
R	-030	2210021500 1K5	5% N4 1K5	SOUCOR	1
R	-031	2500049900 499R * 1% 0,3 U SMA207	499R * 1% 0,3 U SMA207	DRALORIC	1
R	-032	2500049900 499R * 1% 0,3 U SMA207	499R * 1% 0,3 U SMA207	DRALORIC	1
R	-033	2500024900 249R * 1% 0,3 U SMA207	249R * 1% 0,3 U SMA207	DRALORIC	1
R	-034	2500024900 249R * 1% 0,3 U SMA207	249R * 1% 0,3 U SMA207	DRALORIC	1
R	-035	2210026800 6K8	5% N4 6K8	SOUCOR	1
R	-036	2210023300 3K3	5% N4 3K3	SOUCOR	1
R	-037	2210011000 100R	5% N4 100R	SOUCOR	1
R	-038	2500049900 499R * 1% 0,3 U SMA207	499R * 1% 0,3 U SMA207	DRALORIC	1
R	-039	2500049900 499R * 1% 0,3 U SMA207	499R * 1% 0,3 U SMA207	DRALORIC	1
R	-040	2210011000 100R	5% N4 100R	SOUCOR	1
R	-041	2500110000 1K00 * 1% 0,3 U SMA207	1K00 * 1% 0,3 U SMA207	DRALORIC	1
R	-042	2500110000 1K00 * 1% 0,3 U SMA207	1K00 * 1% 0,3 U SMA207	DRALORIC	1
R	-043	2500168100 6K81 * 1% 0,3 U SMA207	6K81 * 1% 0,3 U SMA207	DRALORIC	1
R	-044	2500168100 6K81 * 1% 0,3 U SMA207	6K81 * 1% 0,3 U SMA207	DRALORIC	1
R	-045	2500156200 5K62 * 1% 0,3 U SMA207	5K62 * 1% 0,3 U SMA207	DRALORIC	1
R	-046	2500156200 5K62 * 1% 0,3 U SMA207	5K62 * 1% 0,3 U SMA207	DRALORIC	1
R	-047	2210001200 12R	5% N4 12R	SOUCOR	1
R	-048	2210001200 12R	5% N4 12R	SOUCOR	1
R	-049	2500022100 221R * 1% 0,3 U SMA207	221R * 1% 0,3 U SMA207	DRALORIC	1
R	-050	2500022100 221R * 1% 0,3 U SMA207	221R * 1% 0,3 U SMA207	DRALORIC	1
R	-051	2500924900 24R9 * 1% 0,3 U SMA207	24R9 * 1% 0,3 U SMA207	DRALORIC	1
R	-052	2500924900 24R9 * 1% 0,3 U SMA207	24R9 * 1% 0,3 U SMA207	DRALORIC	1
R	-053	2300094700 4R7 SFR 25 1/4W 5% RC2T	4R7 SFR 25 1/4W 5% RC2T	RTC	1
R	-054	2300095600 5R6 SFR 25 1/4W 5% RC2T	5R6 SFR 25 1/4W 5% RC2T	RTC	1
R	-055	2300095600 5R6 SFR 25 1/4W 5% RC2T	5R6 SFR 25 1/4W 5% RC2T	RTC	1
R	-056	2500110000 1K00 * 1% 0,3 U SMA207	1K00 * 1% 0,3 U SMA207	DRALORIC	1
R	-057	2500010000 100R * 1% 0,3 U SMA207	100R * 1% 0,3 U SMA207	DRALORIC	1
R	-058	2210011000 100R	5% N4 100R	SOUCOR	1
R	-059	2210011000 100R	5% N4 100R	SOUCOR	1

*0269070000 13 CARTE AMPLIFICATEUR . 2230A * 13 AMPLIFIER BOARD 2230A G932353.A976907 *

REPERE INDEXE	REF. ADRET PART NUMBER	DESCRIPTION	PART DESCRIPTION	FOURNISSEUR/PLAN SUPPLIER/DRAWING	QTE QTY
R -060	2500130100	3K01 * 1% 0,3 W	SMA207 * 3K01 * 1% 0,3 W	SMA207 DRALORIC	1
R -061	2500130100	3K01 * 1% 0,3 W	SMA207 * 3K01 * 1% 0,3 W	SMA207 DRALORIC	1
R -062	2500149900	4K99 * 1% 0,3 W	SMA207 * 4K99 * 1% 0,3 W	SMA207 DRALORIC	1
R -063	2500149900	4K99 * 1% 0,3 W	SMA207 * 4K99 * 1% 0,3 W	SMA207 DRALORIC	1
R -064	2210032200	22K	5% N4 * 22K	5% N4 SOUCOR	1
R -065	2210032200	22K	5% N4 * 22K	5% N4 SOUCOR	1
R -066	2500948700	48R7 * 1% 0,3 W	SMA207 * 48R7 * 1% 0,3 W	SMA207 DRALORIC	1
R -067	2210023300	3K3	5% N4 * 3K3	5% N4 SOUCOR	1
R -068	2210011000	100R	5% N4 * 100R	5% N4 SOUCOR	1
R -069	2210011500	150R	5% N4 * 150R	5% N4 SOUCOR	1
R -070	2210022200	2K2	5% N4 * 2K2	5% N4 SOUCOR	1
R -071	2210011000	100R	5% N4 * 100R	5% N4 SOUCOR	1
R -072	2210022200	2K2	5% N4 * 2K2	5% N4 SOUCOR	1
R -073	2210022200	2K2	5% N4 * 2K2	5% N4 SOUCOR	1
R -074	2210024700	4K7	5% N4 * 4K7	5% N4 SOUCOR	1
R -075	2500110000	1K00 * 1% 0,3 W	SMA207 * 1K00 * 1% 0,3 W	SMA207 DRALORIC	1
R -076	2210013300	330R	5% N4 * 330R	5% N4 SOUCOR	1
R -077	2500115000	1K50 * 1% 0,3 W	SMA207 * 1K50 * 1% 0,3 W	SMA207 DRALORIC	1
R -078	2900011000	100R	5% NK3 * 100R	5% NK3 SOUCOR	1
R -079	2500124300	2K43 * 1% 0,3 W	SMA207 * 2K43 * 1% 0,3 W	SMA207 DRALORIC	1
R -080	2210005600	56R	5% N4 * 56R	5% N4 SOUCOR	1
R -081	2500022600	226R * 1% 0,3 W	SMA207 * 226R * 1% 0,3 W	SMA207 DRALORIC	1
R -082	2500022600	226R * 1% 0,3 W	SMA207 * 226R * 1% 0,3 W	SMA207 DRALORIC	1
R -083	2500124300	2K43 * 1% 0,3 W	SMA207 * 2K43 * 1% 0,3 W	SMA207 DRALORIC	1
R -084	2500157600	5K76 * 1% 0,3 W	SMA207 * 5K76 * 1% 0,3 W	SMA207 DRALORIC	1
R -085	2500049900	499R * 1% 0,3 W	SMA207 * 499R * 1% 0,3 W	SMA207 DRALORIC	1
R -086	2500049900	499R * 1% 0,3 W	SMA207 * 499R * 1% 0,3 W	SMA207 DRALORIC	1
R -087	2210004700	47R	5% N4 * 47R	5% N4 SOUCOR	1
R -088	2210004700	47R	5% N4 * 47R	5% N4 SOUCOR	1
R -089	2210034700	47K	5% N4 * 47K	5% N4 SOUCOR	1
R -090	2210034700	47K	5% N4 * 47K	5% N4 SOUCOR	1
R -091	2210032200	22K	5% N4 * 22K	5% N4 SOUCOR	1
R -092	2500210000	10K0 * 1% 0,3 W	SMA207 * 10K0 * 1% 0,3 W	SMA207 DRALORIC	1
R -093	2500210000	10K0 * 1% 0,3 W	SMA207 * 10K0 * 1% 0,3 W	SMA207 DRALORIC	1
R -094	2210024700	4K7	5% N4 * 4K7	5% N4 SOUCOR	1
R -095	2210031000	10K	5% N4 * 10K	5% N4 SOUCOR	1
R -096	2500210000	10K0 * 1% 0,3 W	SMA207 * 10K0 * 1% 0,3 W	SMA207 DRALORIC	1
R -097	2210023300	3K3	5% N4 * 3K3	5% N4 SOUCOR	1
R -098	2500215000	15K0 * 1% 0,3 W	SMA207 * 15K0 * 1% 0,3 W	SMA207 DRALORIC	1
R -099	2210041200	120K	5% N4 * 120K	5% N4 SOUCOR	1
R -100	2200052200	2M2 5% CB	2M2 5% CB	CB ALLEN BRADLEY	1
R -101	2500168100	6K81 * 1% 0,3 W	SMA207 * 6K81 * 1% 0,3 W	SMA207 DRALORIC	1
R -102	2300094700	4R7 SFR 25 1/4W 5% RC2T	4R7 SFR 25 1/4W 5% RC2T	RTC	1
R -103	2300094700	4R7 SFR 25 1/4W 5% RC2T	4R7 SFR 25 1/4W 5% RC2T	RTC	1
R -104	2210005100	51R	5% N4 * 51R	5% N4 SOUCOR	1
SN -001	4200090000	LM 741 CN B+ . DIP 8 PATTES ..	LM 741 CN B+ . DIP 8 PINS	NS	1
SN -002	4200110000	TBA 673 MODULATEUR 4 QUADRANS.	TBA 673 MODULATOR 4 FACES	RTC	1
SN -003	4200090000	LM 741 CN B+ . DIP 8 PATTES ..	LM 741 CN B+ . DIP 8 PINS	NS	1
SN -004	4200090000	LM 741 CN B+ . DIP 8 PATTES ..	LM 741 CN B+ . DIP 8 PINS	NS	1
SN -005	4200180000	LM 1458 N B+ DIP 8 PATTES	LM 1458 N B+ DIP 8 PINS	NS	1
T -001	0218030000	00 F2 30X38+38	2200A	00 F2 30X38+38 TURNS	2200A Z94 F2.....106
T -002	0218040000	00 F2 16X2 SPIRES	2200A	00 F2 16X2 TURNS	2200A Z94 F2.....18
T -003	0216280000	01 F2 63 SPIRES	2200A	01 F2 63 TURNS	2200A Z94 F2.....63
T -004	0218050000	00 F2 2X4+4	2200A	00 F2 2X4+4 TURNS	2200A Z94 F2.....10
T -005	0218060000	00 F2 46X46 SPIRES	2200A	00 F2 46X46 TURNS	2200A Z94 F2.....92
T -006	0217170000	00 F2 95 SPIRES	2200A	00 F2 95 TURNS	2200A Z94 F2.....95
T -007	0217170000	00 F2 95 SPIRES	2200A	00 F2 95 TURNS	2200A Z94 F2.....95
T -008	0217280000	01 TORE FT5 T6	2230A	01 TORE FT5 T6	ADRET.....
Z0 -004	0206760000	00 ETIQUETTE 6907	2230A	00 LABEL 6907	2230A 942375.....
Z1	1269070400	CI DEMODULATEUR AMPLI ..	2230A	PC AMPLI DEMODULATOR ...	2230A L996907.....TM
Z1	1400109900	POINT TEST		TEST POINT	C940850
Z1	1900200000	EXTRACTEUR DE CARTE 'ELEVATEUR'		BOARD EXTRACTOR 'LIFTER'	TRELEC
Z4	4900070000	ENTRETOISE T05	T05-001	SPACER T05	T05-001 JERMYN
Z4	4900080000	ENTRETOISE DE CI	MON 10L	PC SPACER	MON 10L JERMYN
Z4	4900250000	ENTRETOISE T018-019D		SPACER T018-019D	JERMYN
Z5	5400050000	CALE ISOLANTE NEOSID POUR CI ..		NEOSID INSULATING QUOIN FOR PC	940008
Z5	5500170000	TORE 4B1 3,7X1,2X3,5		TORE 4B1 3.7X1.2X3.5	RTC
Z6	6400530000	OEUillet LAITON	N° 2070	FIXING EYELET BRASS ..	N° 2070 MFORM

CONVERTISSEUR NUMERIQUE / ANALOGIQUE
DIGITAL / ANALOG CONVERTER

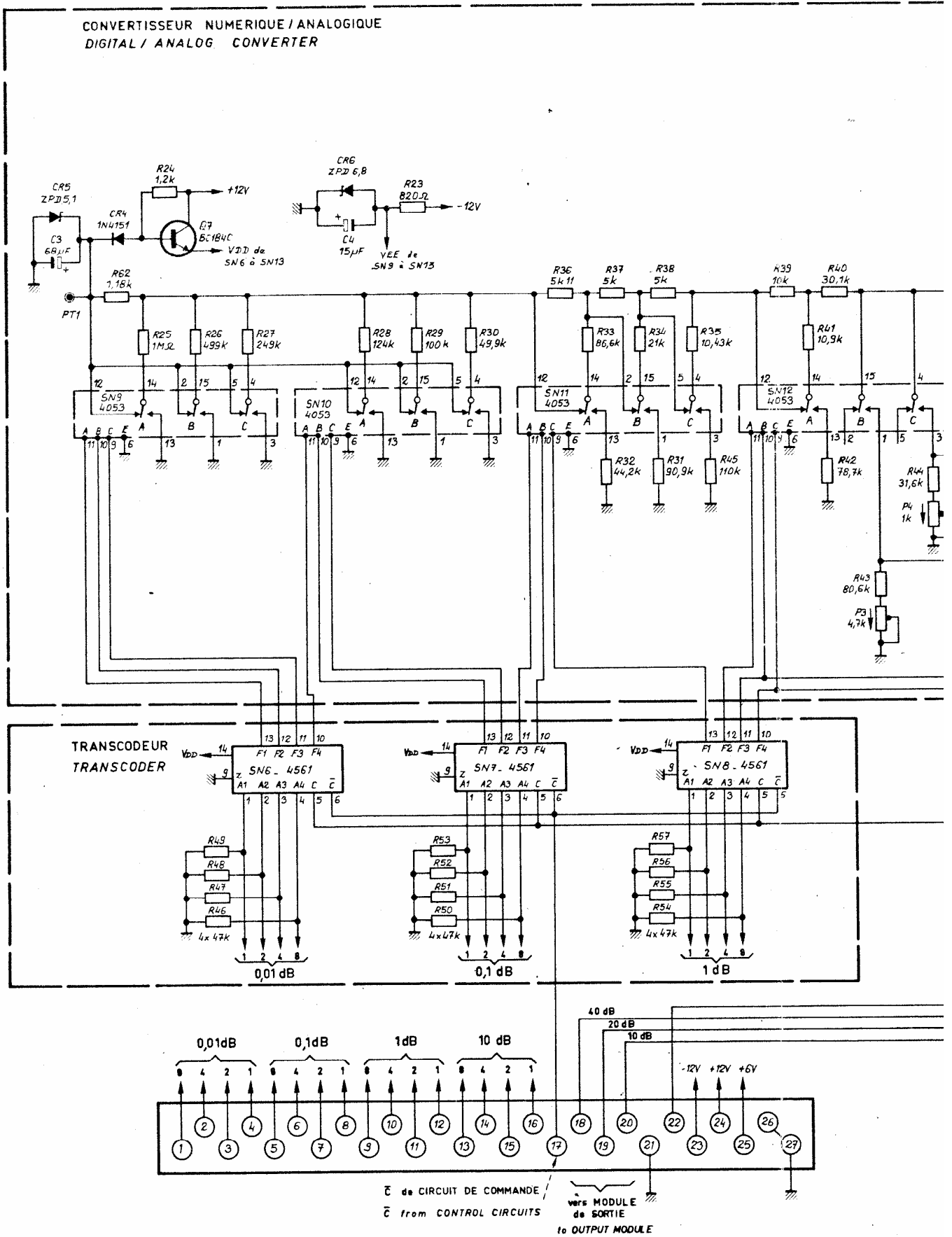

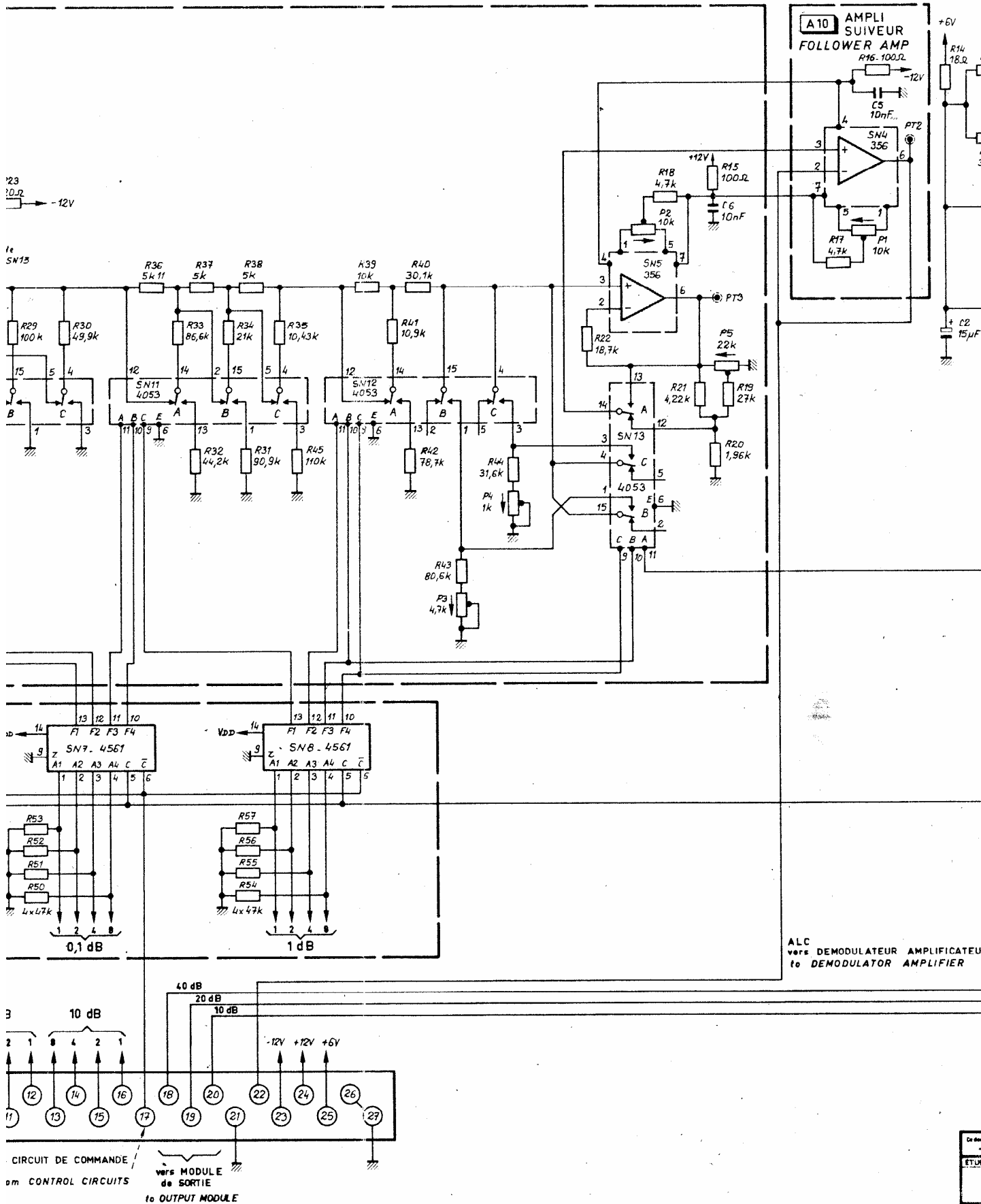

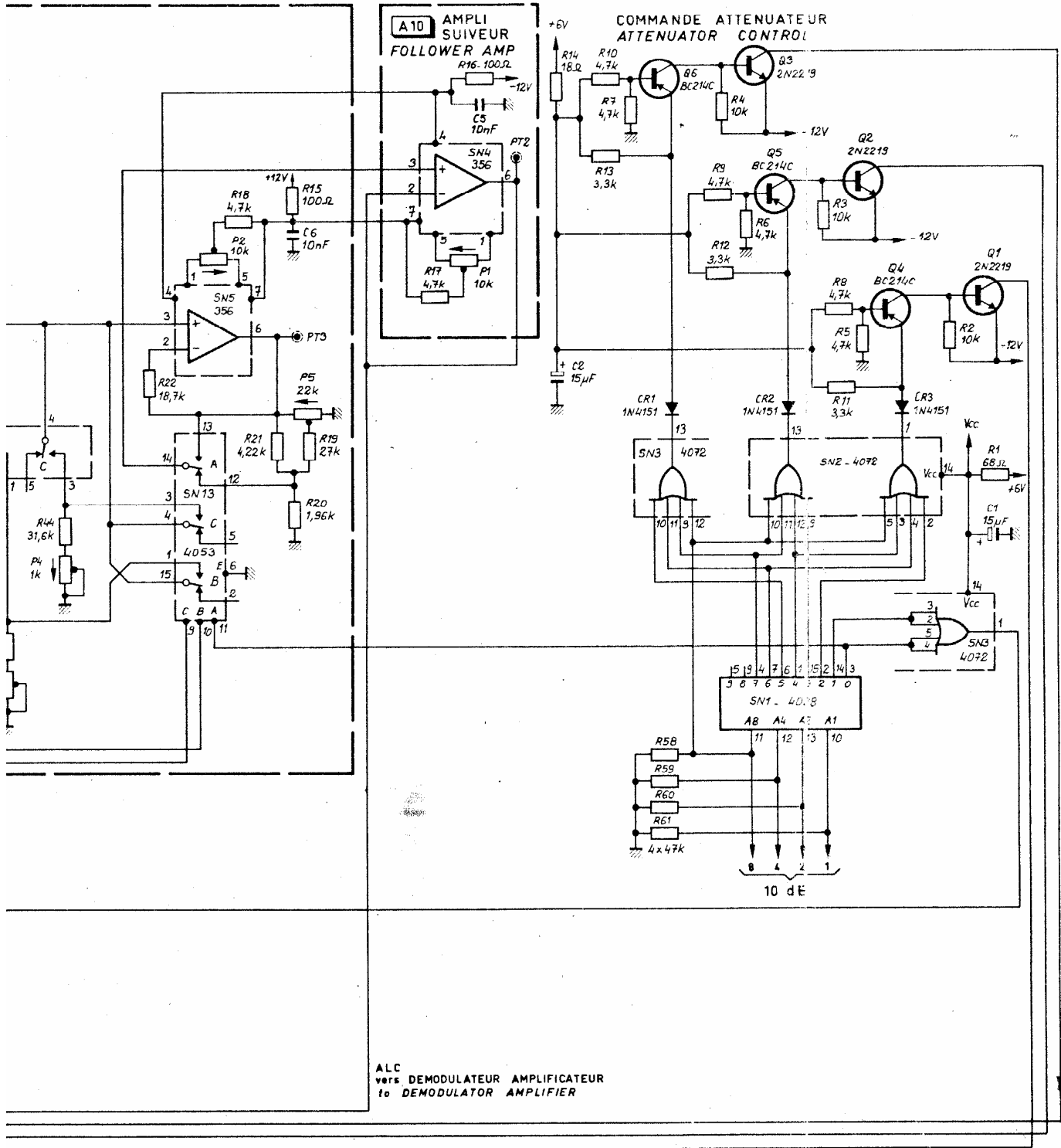
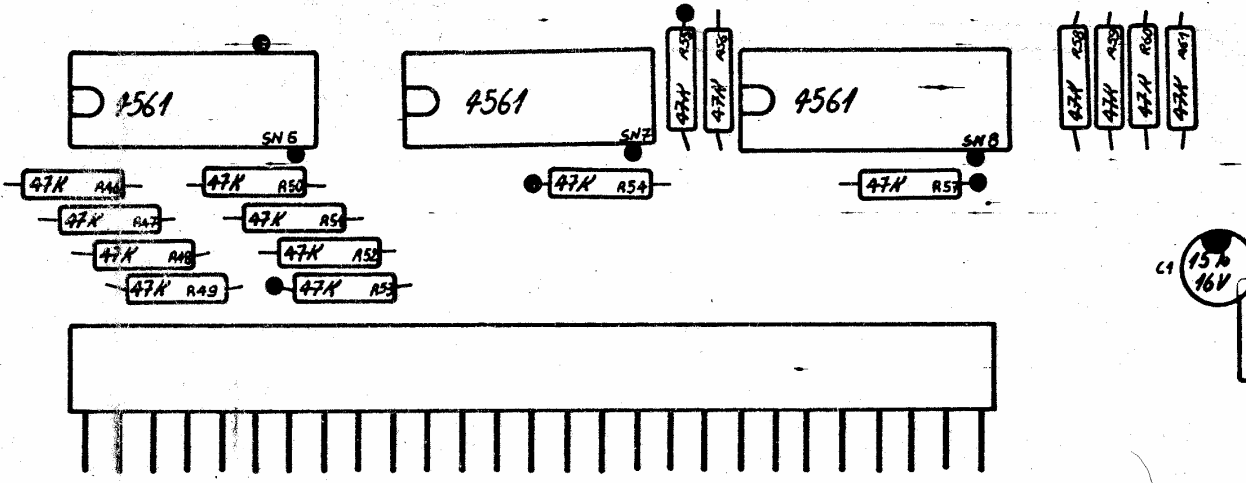
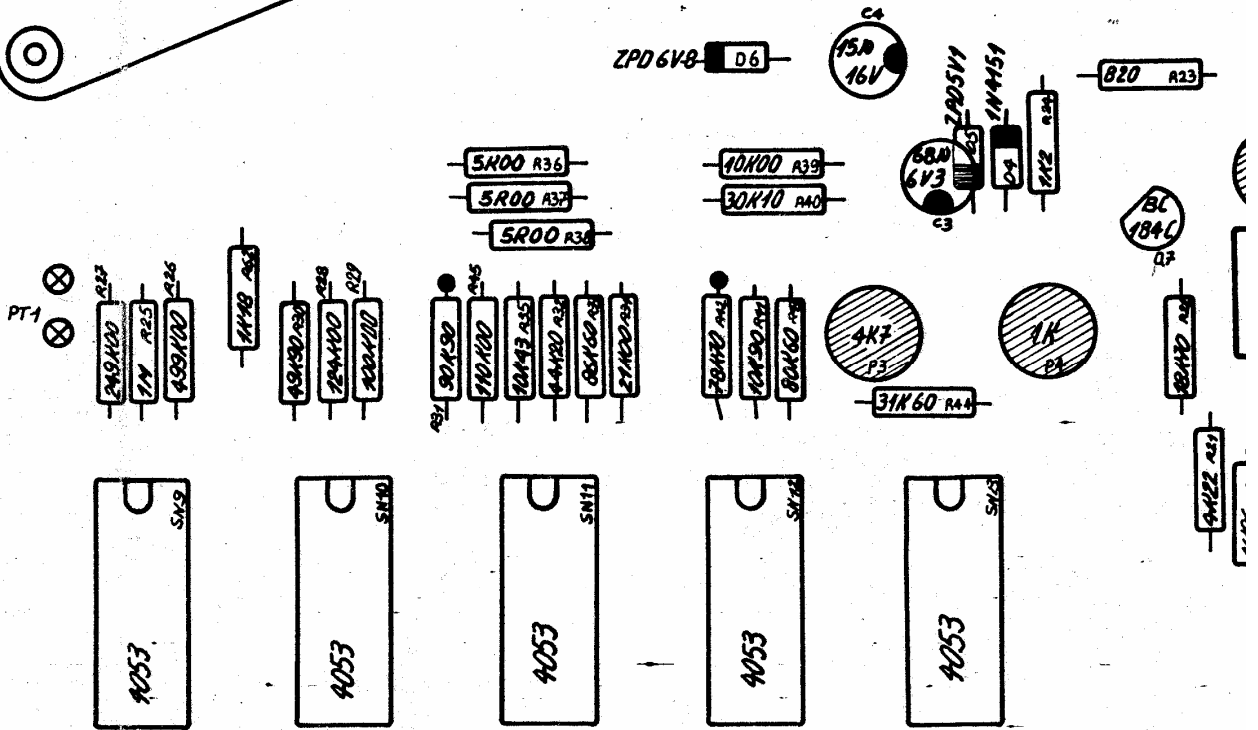
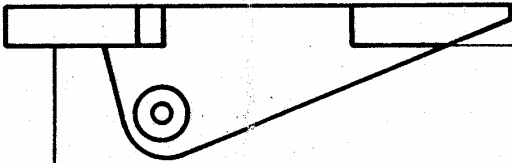

PLATE V.5
 PLANCHE V.5

Ce document ne peut être communiqué à l'extérieur sans autorisation		radiotéléphonique	DATE: JUILLET 1978
ETUDE	DESSIN	VERIFIE	PAGE: 1 / 1
ACORT	H.V.	2230 A CODAGE NIVEAU DE SORTIE OUTPUT LEVEL CODING	976908A



REPERE INDEXE	REF. ADRET PART NUMBER	DESCRIPTION	PART DESCRIPTION	FOURNISSEUR/PLAN SUPPLIER/DRAWING	QTE QTY
B -001	1427011600	TM 27 MCIG	MALE*CARTE#	TM 27 MCIG MALE TREC	1
C -001	3700180000	22MMF/16V 5,08	STAND L TAG	22MMF/16V 5,08 STAND L TAG	1
C -002	3700180000	22MMF/16V 5,08	STAND L TAG	22MMF/16V 5,08 STAND L TAG	1
C -003	3700250000	47MMF/6,3V 5,08	STAND L TAG	47MMF/6,3V 5,08 STAND L TAG	1
C -004	3700180000	22MMF/16V 5,08	STAND L TAG	22MMF/16V 5,08 STAND L TAG	1
C -005	3150031000	10NF 5,08 63V	GOX 767 14	10NF 5,08 63V GOX 767 14	1
C -006	3150031000	10NF 5,08 63V	GOX 767 14	10NF 5,08 63V GOX 767 14	1
D -001	4500020000	1N4151		1N4151 FU'ITT	1
D -002	4500020000	1N4151		1N4151 FU'ITT	1
D -003	4500020000	1N4151		1N4151 FU'ITT	1
D -004	4500020000	1N4151		1N4151 FU'ITT	1
D -005	4600030000	ZPD5,1		ZPD5,1 ITT	1
D -006	4600080000	ZPD6,8		ZPD6,8 ITT	1
P -001	2153100000	10K T05 CERMET	T 7 YA	10K T05 CERMET T 7 YA	1
P -002	2153100000	10K T05 CERMET	T 7 YA	10K T05 CERMET T 7 YA	1
P -003	2152470000	4K7 T05 CERMET	T 7 YA	4K7 T05 CERMET T 7 YA	1
P -004	2152100000	1 K T05 CERMET	T 7 YA	1 K T05 CERMET T 7 YA	1
P -005	2153220000	22K T05 CERMET	T 7 YA	22K T05 CERMET T 7 YA	1
Q -001	4800060000	2N2219		2N2219 RTC	1
Q -002	4800060000	2N2219		2N2219 RTC	1
Q -003	4800060000	2N2219		2N2219 RTC	1
Q -004	4300110000	BC560C /416C/415C/559C(BC214C)		BC560C /413C/415C/559C(BC214C) RTC	1
Q -005	4300110000	BC560C /416C/415C/559C(BC214C)		BC560C /413C/415C/559C(BC214C) RTC	1
Q -006	4300110000	BC560C /416C/415C/559C(BC214C)		BC560C /413C/415C/559C(BC214C) RTC	1
Q -007	4300190000	BC550C /414C/413C/549C(BC184C)		BC550C /414C/413C/549C(BC184C) RTC	1
R -001	2210006800	68R	5% N4	68R 5% N4 SOUCOR	1
R -002	2210031000	10K	5% N4	10K 5% N4 SOUCOR	1
R -003	2210031000	10K	5% N4	10K 5% N4 SOUCOR	1
R -004	2210031000	10K	5% N4	10K 5% N4 SOUCOR	1
R -005	2210024700	4K7	5% N4	4K7 5% N4 SOUCOR	1
R -006	2210024700	4K7	5% N4	4K7 5% N4 SOUCOR	1
R -007	2210024700	4K7	5% N4	4K7 5% N4 SOUCOR	1
R -008	2210024700	4K7	5% N4	4K7 5% N4 SOUCOR	1
R -009	2210024700	4K7	5% N4	4K7 5% N4 SOUCOR	1
R -010	2210024700	4K7	5% N4	4K7 5% N4 SOUCOR	1
R -011	2210023300	3K3	5% N4	3K3 5% N4 SOUCOR	1
R -012	2210023300	3K3	5% N4	3K3 5% N4 SOUCOR	1
R -013	2210023300	3K3	5% N4	3K3 5% N4 SOUCOR	1
R -014	2210001800	18R	5% N4	18R 5% N4 SOUCOR	1
R -015	2210011000	100R	5% N4	100R 5% N4 SOUCOR	1
R -016	2210011000	100R	5% N4	100R 5% N4 SOUCOR	1
R -017	2210024700	4K7	5% N4	4K7 5% N4 SOUCOR	1
R -018	2210024700	4K7	5% N4	4K7 5% N4 SOUCOR	1
R -019	2210032700	27K	5% N4	27K 5% N4 SOUCOR	1
R -020	2500119600	1K96	1% 0,3 W	SMA207 1K96 1% 0,3 W	1
R -021	2500142200	4K22	1% 0,3 W	SMA207 4K22 1% 0,3 W	1
R -022	2500218700	18K7	1% 0,3 W	SMA207 18K7 1% 0,3 W	1
R -023	2210018200	820R	5% N4	820R 5% N4 SOUCOR	1
R -024	2210021200	1K2	5% N4	1K2 5% N4 SOUCOR	1
R -025	2210051000	1M	5% N4	1M 5% N4 SOUCOR	1
R -026	2500349900	499K	1% 0,3 W	SMA207 499K 1% 0,3 W	1
R -027	2500324900	249K	1% 0,3 W	SMA207 249K 1% 0,3 W	1
R -028	2500312400	124K	1% 0,3 W	SMA207 124K 1% 0,3 W	1
R -029	2500310000	100K	1% 0,3 W	SMA207 100K 1% 0,3 W	1
R -030	2500249900	49K9	1% 0,3 W	SMA207 49K9 1% 0,3 W	1
R -031	2500290900	90K9	1% 0,3 W	SMA207 90K9 1% 0,3 W	1
R -032	2500244200	44K2	1% 0,3 W	SMA207 44K2 1% 0,3 W	1
R -033	2500286600	86K6	1% 0,3 W	SMA207 86K6 1% 0,3 W	1
R -034	2500221000	21K0	1% 0,3 W	SMA207 21K0 1% 0,3 W	1
R -035	2601104300	10K43	0,25% 50PPM	H10 10K43 0,25% 50PPM	1
R -036	2500151100	5K11	1% 0,3 W	SMA207 5K11 1% 0,3 W	1
R -037	2600500000	5K00	0,25% 50PPM	H10 5K00 0,25% 50PPM	1
R -038	2600500000	5K00	0,25% 50PPM	H10 5K00 0,25% 50PPM	1
R -039	2601100000	10K00	0,25% 50PPM	H10 10K00 0,25% 50PPM	1
R -040	2601301000	30K10	0,25% 50PPM	H10 30K10 0,25% 50PPM	1
R -041	2601109000	10K90	0,25% 50PPM	H10 10K90 0,25% 50PPM	1
R -042	2500278700	78K7	1% 0,3 W	SMA207 78K7 1% 0,3 W	1
R -043	2500280600	80K6	1% 0,3 W	SMA207 80K6 1% 0,3 W	1
R -044	2500231600	31K6	1% 0,3 W	SMA207 31K6 1% 0,3 W	1
R -045	2500311000	110K	1% 0,3 W	SMA207 110K 1% 0,3 W	1
R -046	2210034700	47K	5% N4	47K 5% N4 SOUCOR	1
R -047	2210034700	47K	5% N4	47K 5% N4 SOUCOR	1
R -048	2210034700	47K	5% N4	47K 5% N4 SOUCOR	1
R -049	2210034700	47K	5% N4	47K 5% N4 SOUCOR	1
R -050	2210034700	47K	5% N4	47K 5% N4 SOUCOR	1
R -051	2210034700	47K	5% N4	47K 5% N4 SOUCOR	1
R -052	2210034700	47K	5% N4	47K 5% N4 SOUCOR	1
R -053	2210034700	47K	5% N4	47K 5% N4 SOUCOR	1
R -054	2210034700	47K	5% N4	47K 5% N4 SOUCOR	1

REPERE INDEXE	REF. ADRET PART NUMBER	DESCRIPTION	PART DESCRIPTION	FOURNISSEUR/PLAN SUPPLIER/DRAWING	QTE QTY
R -055	2210034700	47K	5% N4 * 47K	5% N4 SOUCOR	1
R -056	2210034700	47K	5% N4 * 47K	5% N4 SOUCOR	1
R -057	2210034700	47K	5% N4 * 47K	5% N4 SOUCOR	1
R -058	2210034700	47K	5% N4 * 47K	5% N4 SOUCOR	1
R -059	2210034700	47K	5% N4 * 47K	5% N4 SOUCOR	1
R -060	2210034700	47K	5% N4 * 47K	5% N4 SOUCOR	1
R -061	2210034700	47K	5% N4 * 47K	5% N4 SOUCOR	1
R -062	2600118000	1K18 0,25% 50PPM	H10 * 1K18 0,25% 50PPM	H10 HOLCO	1
SN -001	4160402800	C-MOS 4028	* C-MOS 4028	RTC	1
SN -002	4160407200	C-MOS 4072	* C-MOS 4072	RTC	1
SN -003	4160407200	C-MOS 4072	* C-MOS 4072	RTC	1
SN -004	4200320000	LF 356 N B+	* LF 356 N B+	NS	1
SN -005	4200320000	LF 356 N B+	* LF 356 N B+	NS	1
SN -006	4160456100	C-MOS 4561 MC 14561 BCP	* C-MOS 4561 MC 14561 BCP	MOTOROLA	1
SN -007	4160456100	C-MOS 4561 MC 14561 BCP	* C-MOS 4561 MC 14561 BCP	MOTOROLA	1
SN -008	4160456100	C-MOS 4561 MC 14561 BCP	* C-MOS 4561 MC 14561 BCP	MOTOROLA	1
SN -009	4160405300	C-MOS 4053	* C-MOS 4053	RTC	1
SN -010	4160405300	C-MOS 4053	* C-MOS 4053	RTC	1
SN -011	4160405300	C-MOS 4053	* C-MOS 4053	RTC	1
SN -012	4160405300	C-MOS 4053	* C-MOS 4053	RTC	1
SN -013	4160405300	C-MOS 4053	* C-MOS 4053	RTC	1
Z0	0206770000	00 ETIQUETTE 6908	2230A * 00 LABEL 6908	2230A 942375.....	1
Z1	1269080600	CI COMMANDE NIVEAU	2230A * PC LEVEL CONTROL	2230A G996908	1
Z1	1400109900	POINT TEST	* TEST POINT	C940850	5
Z1	1900200000	EXTRACTEUR DE CARTE ELEVATEUR	* BOARD EXTRACTOR LIFTER	TRELEC	2
Z4	4900070000	ENTRETOISE T05	T05-001 * SPACER T05	T05-001 JERMYN	3
Z4	4900310000	16 SUPPORT C.I. DIL	J23-5016 * 16 CONNECTOR P.C. DIL	J23-5016 JERMYN	5
Z6	6400530000	OUILLET LAITON	N° 2070 * FIXING EYELET BRASS	N° 2070 MFOH	2

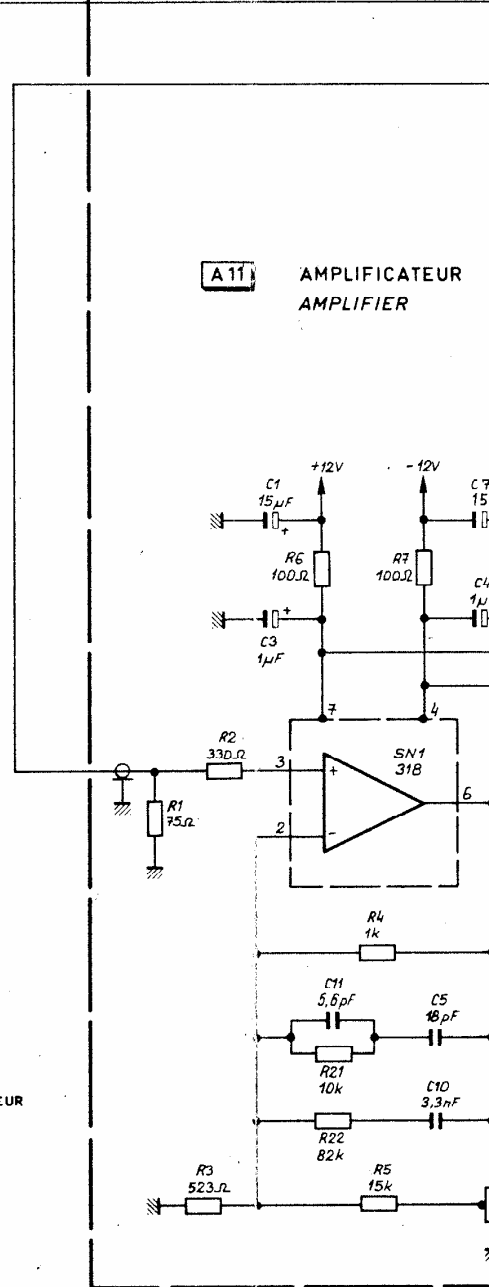
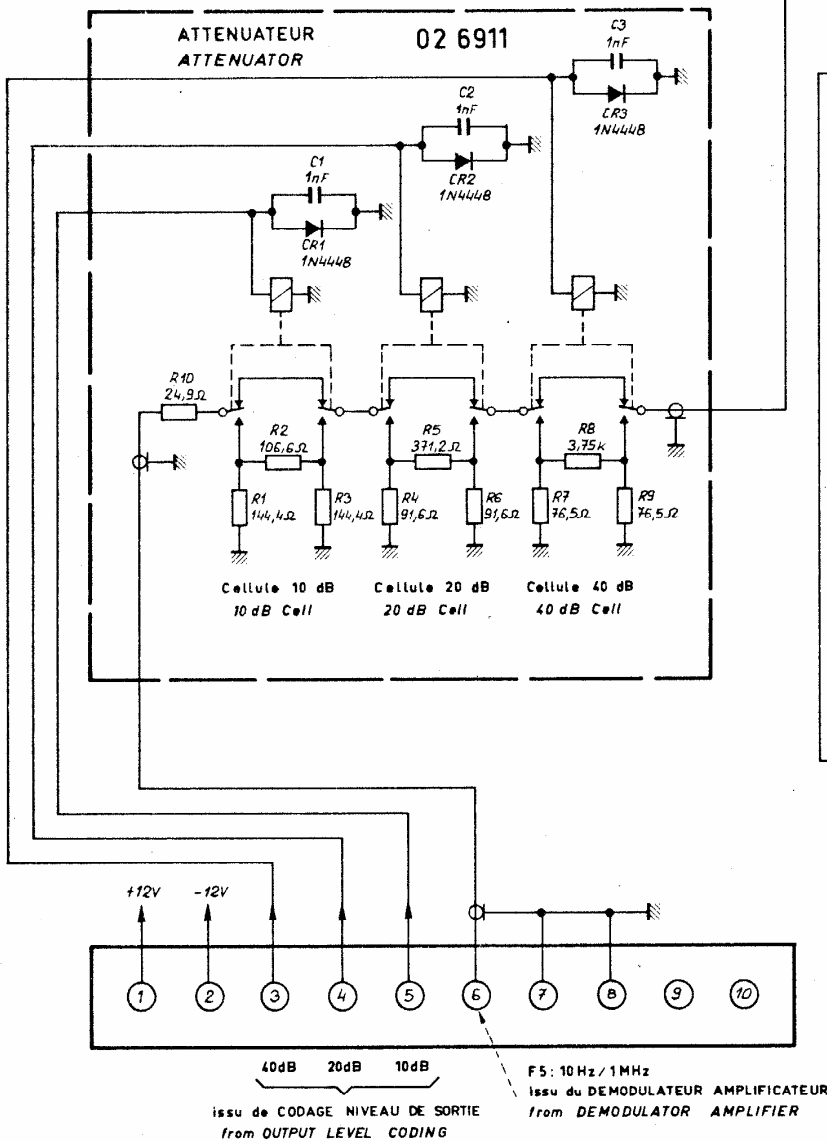

02 6912

A 11 AMPLIFICATEUR
AMPLIFIER

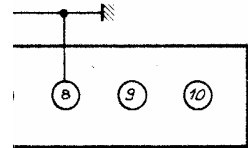
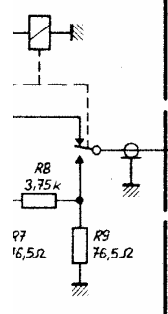
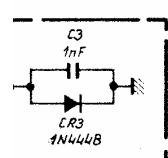

10 Hz / 1 MHz
du DEMODULATEUR AMPLIFICATEUR
d DEMODULATOR AMPLIFIER

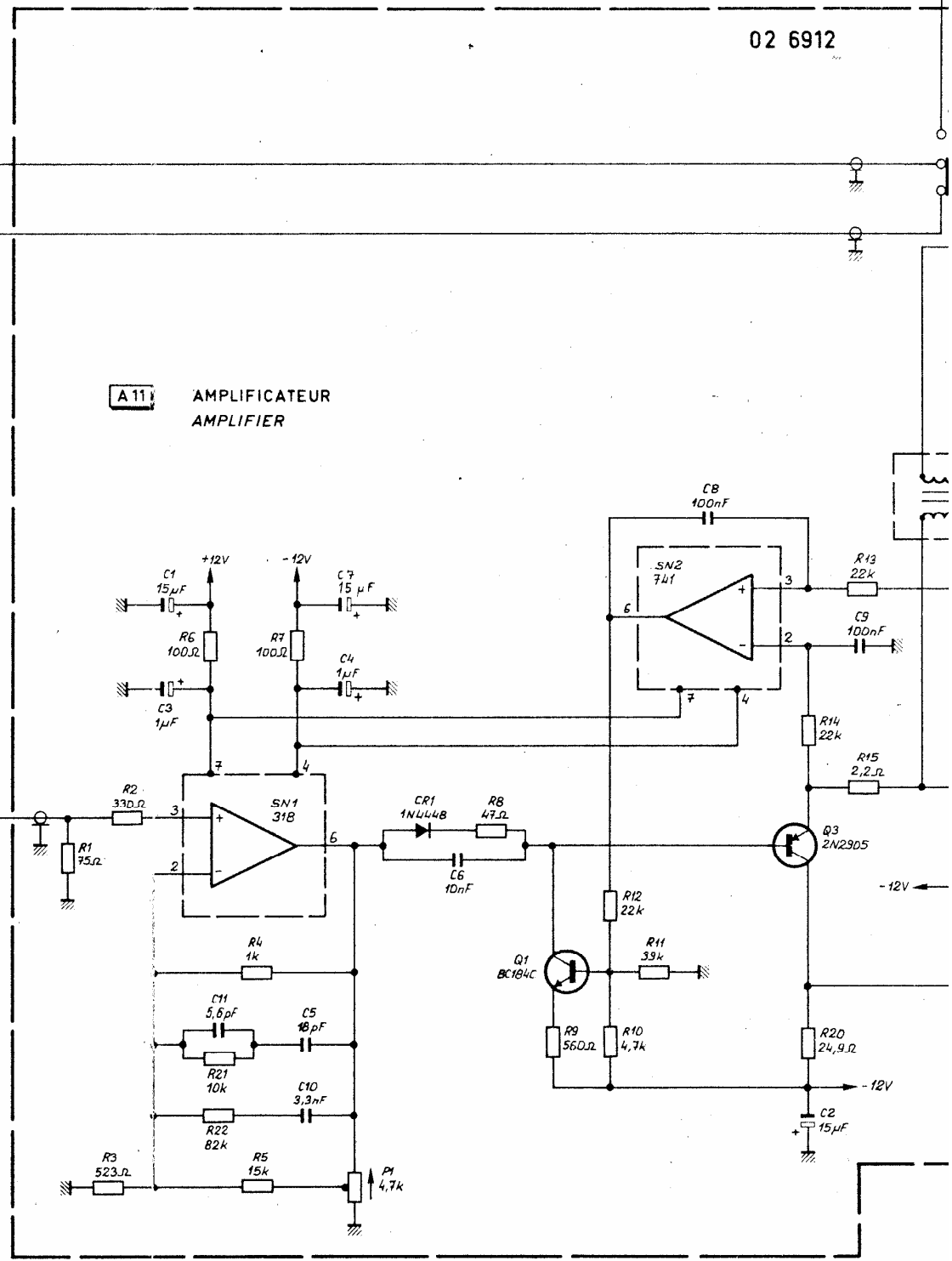

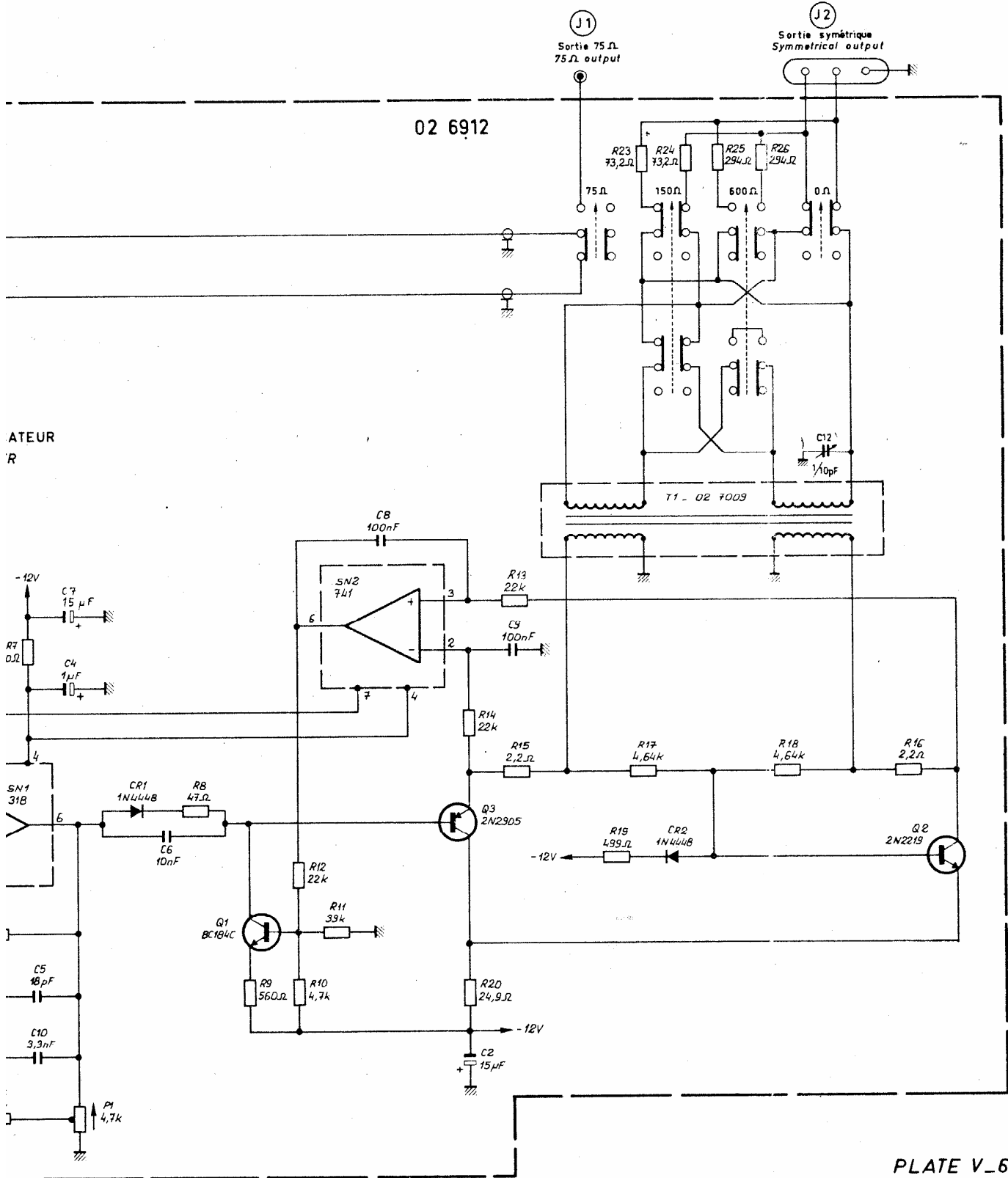
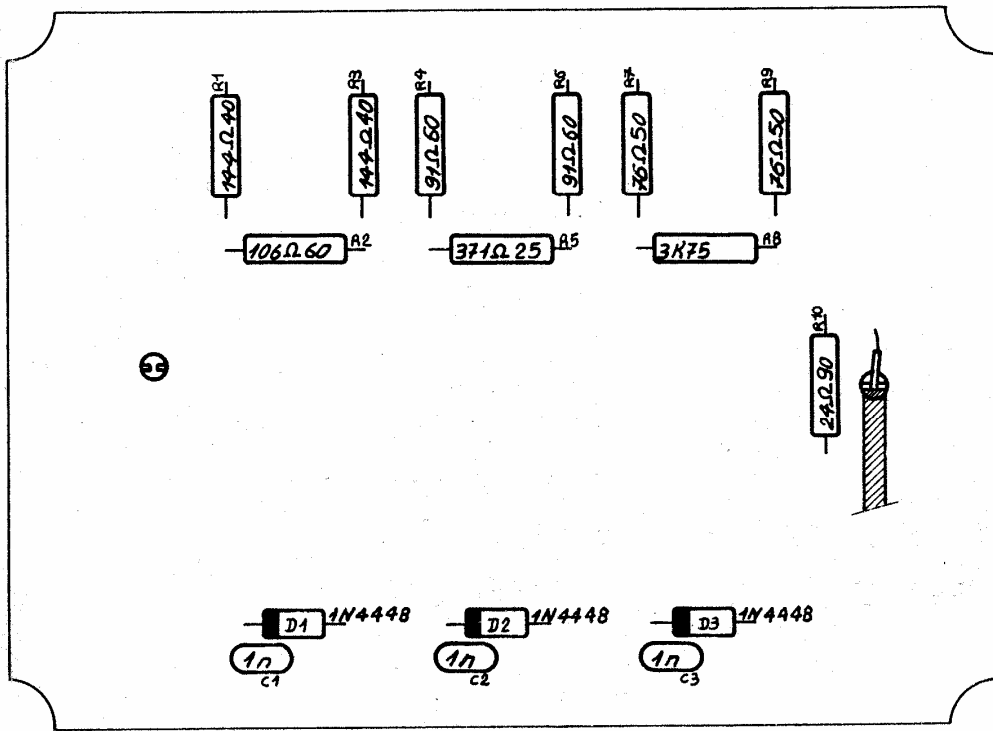
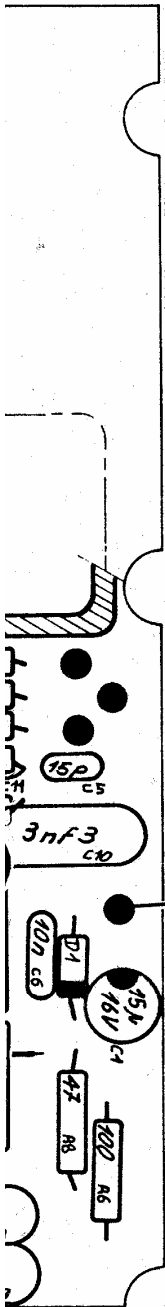

PLATE V_6
 PLANCHE V_6

Ce document ne peut être communiqué ni reproduit sans autorisation.			schret électronique		DATE : JUILLET 1978
ÉTUDE	DESSIN	VÉRIFIE	223 A		PAGE : 1 / 1
ACORT	H.V.		MODULE DE SORTIE		976910C
			OUTPUT MODULE		



 *026910000 11 BAQUET DE SORTIE 2230A * 11 OUTPUT MODULE 2230A J920871.C976910 *

REPERE INDEXE	REF. ADRET PART NUMBER	DESCRIPTION	PART DESCRIPTION	FOURNISSEUR/PLAN SUPPLIER/DRAWING	QTE QTY
	001 0269110000	03 ATTENUATEUR	2230A * 03 ATTENUATOR	2230A C932524.....	1
	001 0269120000	11 AMPLI SYMETRIQUE	2230A * 11 SYMMETRICAL AMPLI ...	2230A H932351 1&2/2..	1
	-012 3600050000	2/10 PF ... REF C010 808	23109 * 2/10 PF ... REF C010 808	23109 RTC (C010)	1
C	-001 2152470000	4K7 T05 CERMET T 7 YA	* 4K7 T05 CERMET T 7 YA	SFERNICE	1
P	0270090000	02 TRANSFO DE SORTIE ...	2230A * 02 OUTPUT TRANSFO	2230A A920936.....	1
Z0	1100030000	FIL ROUGE	KY30-04 * RED THREAD	KY30-04 FILECA	0
Z1	1100070000	FIL BLEU	KY30-04 * BLUE THREAD	KY30-04 FILECA	0
Z1	1100440000	CABLE BLINDE GRIS	FMA2R * GREY ARMORED CABLE	FMA2R FILECA	0
Z1	1100530000	FIL.NU.ETAME.6/10	* TINNED BARE THREAD 6/10	ELECTROFIL	0
Z1	1100550000	FIL.NU.ETAME.10/10	* TINNED BARE THREAD10/10	ELECTROFIL	0
Z1	1300450000	GAINÉ F4,8 FP301 3/16 SFM 48	* SHEATH F4.8 FP301 3/16 SFM 48	HELLERMANN	0
Z1	1300610000	PASSE.FIL	REF 751 * FEED-THROUGH SLEEVE ...REF 751	MFOM	1
Z1	1400215800	BNC EMBASE ECROU FEMEL R141559	* BNC BASE THUMB FEMALE .R141559	RADIALL	1
Z1	1400217200	PRISE SIEMENS C42334 A176 A11	* SIEMENS PLUG C42334 A176 A11	SIEMENS	1
Z1	1410007600	TB 10 M	MALE * TB 10 M	MALE TREC	1
Z1	1520412300	04 TOUCHES ORE 10 BAQSYM 2230A	* 04 TOUCHES ORE 10 BAQSYM 2230A	D932472	1
Z1	1600090000	RELAYS 2 INV. G2V-234P-NT.12DC	* RELAYS 2 REV. G2V-234P-NT.12DC	OMRON	3
Z1	1900010000	GUIDE CARTE ANTIU.FIXAT. PIONS	* BOARD GUIDE FIXATION PIONS	TREC	1
Z3	3100430000	1000PF TRAVERSEE 8020D4000400V	* 1000PF PINCH 8020D4000400V	BD	2
Z5	5500110000	TUBE B30 GT 4.1X2X12.5	* TUBE B30 GT 4.1X2X12.5	COFELEC	1
Z6	6100030800	TCB M3X 8 U DIN7985-4,8 INOX	* TCB M3X 8 U DIN7985-4,8 INOX	BD	2
Z6	6107241900	N'4X19 ACI A TOLE F/80' CRUCIF	* N'4X19 ACI A TOLE F/80' CRUCIF	SAGIC	2
Z6	6130110400	LAD 2,5X 4 CYLINDRIQUE FENDUE	* LAD 2,5 X 4 CYLINDRIQUE FENDUE	SAGIC	16
Z6	6130110500	LAD 2,5X 5 CYLINDRIQUE FENDUE	* LAD 2.5 X 5 CYLINDER SLOT	SAGIC	6
Z6	6130111000	LAD 2,5X10 CYLINDRIQUE FENDUE	* LAD 2.5 X 10 CYLINDER SLOT ...	SAGIC	2
Z6	6200010000	ECROU H M2,5 U NFE27-411-5 INOX	* NUT H M2.5 U NFE27-411-5 INOX	BD	3
Z6	6200030000	ECROU H M3 U NF E27-411-5 INOX	* NUT H M3 U NF E27-411-5 INOX	BD	2
Z6	6220010000	LAI 2,5 HEXAGONAL USUEL 'H'	* BRASS 2.5 USUAL HEXAGON 'H'	SAGIC	2
Z6	6301010000	DI 2,5 EVENTAIL NFE27-618 INOX	* DI 2.5 FAN NFE27-618 INOX	BD	2
Z6	6305030000	ACI 3 CONTACT REF 55-03-01	* STEEL 3 CONTACT REF 55-03-01	NOMEL	2
Z6	6400350000	COSSE A SOUDER	2003E * SOLDERING TERMINAL	2003E MFOM	1
Z6	6400670000	RIVET POP 3,2 L 4 ALU ABS 41	* POP RIVET 3.2 L 4 ALU ABS 41	MFOM	2
Z8	8006710600	FOND AMPLI-ATTENUATEUR .. 2230A	* AMPLI-ATT. BACKGROUND .. 2230A	E932163.....	1
Z8	8006710800	PLATINE AVANT AMPLI-ATTE 2230A	* AMPLI-ATT.FRONT MOUNTING 2230A	D942100	1
Z8	8006710900	COUVERCLE AMPLI-ATTENUAT 2230A	* AMPLI-ATTENUATOR COVER . 2230A	C932162	1
Z8	8006733000	RONDILLE BNC 12X10X2 2230A	* WASHER BNC 12X10X2	2230A A942291	2
Z8	8006763200	TOUCHE GRISE D6H11 OREOR 2230A	* GREY TOUCH D6H11 OREOR 2230A	A942431	4
Z8	8106710300	01 BAQ AMPLI ATTENUATEUR 2230A	* 01 ATTEN. AMPLI MODULE . 2230A	D920776	1

*0269110000 03 ATTENUATEUR 2230A * 03 ATTENUATOR 2230A C932524.....*

REPERE INDEXE	REF. ADRET PART NUMBER	DESCRIPTION	PART DESCRIPTION	FOURNISSEUR/PLAN SUPPLIER/DRAWING	QTE QTY
C -001	3120021000	1 NF 2,5 2222 630 51 102	* 1 NF 2,5 2222 630 51 102	COGECO	1
C -002	3120021000	1 NF 2,5 2222 630 51 102	* 1 NF 2,5 2222 630 51 102	COGECO	1
C -003	3120021000	1 NF 2,5 2222 630 51 102	* 1 NF 2,5 2222 630 51 102	COGECO	1
D -001	4500310000	1 N 4448	* 1 N 4448	ITT	1
D -002	4500310000	1 N 4448	* 1 N 4448	ITT	1
D -003	4500310000	1 N 4448	* 1 N 4448	ITT	1
R -001	2609144400	144R4 0,25% 50PPM REF H10	* 144R4 0,25% 50PPM REF H10	HOLCO	1
R -002	2609106600	106R6 0,25% 50PPM REF H10	* 106R6 0,25% 50PPM REF H10	HOLCO	1
R -003	2609144400	144R4 0,25% 50PPM REF H10	* 144R4 0,25% 50PPM REF H10	HOLCO	1
R -004	2608916000	91R6 0,25% 50PPM REF H10	* 91R6 0,25% 50PPM REF H10	HOLCO	1
R -005	2683712500	371.25 0,1% 25PPM AUL	* 371.25 0,1% 25PPM AUL	GEKA	1
R -006	2608916000	91R6 0,25% 50PPM REF H10	* 91R6 0,25% 50PPM REF H10	HOLCO	1
R -007	2608765000	76R5 0,25% 50PPM REF H10	* 76R5 0,25% 50PPM REF H10	HOLCO	1
R -008	2693750000	3K75 0,1% 25PPM AUL	* 3K75 0,1% 25PPM AUL	GEKA	1
R -009	2608765000	76R5 0,25% 50PPM REF H10	* 76R5 0,25% 50PPM REF H10	HOLCO	1
R -010	2500924900	24R9 * 1% 0,3 U SMA207	* 24R9 * 1% 0,3 U SMA207	DRALORIC	1
Z1	1100020000	FIL MARRON KY30-04	* BROWN THREAD KY30-04	FILECA	0
Z1	1100060000	FIL VERT KY30-04	* GREEN THREAD KY30-04	FILECA	0
Z1	1100090000	FIL GRIS KY30-04	* GREY THREAD KY30-04	FILECA	0
Z1	1100430000	COAX KX 21 A KY30-04	* COAX KX 21 A KY30-04	FILECA	0
Z1	1269110200	CI ATTENUATEUR 2230A	* PC ATTENUATOR 2230A	F996911.....SF	1
Z6	6400280000	PLOT A FOURCHE SOUDE . BFMQ13C	* SOLDERED FORK CONTACT BFMQ13C	COMATEL	2

*0269120000 11 AMPLI SYMETRIQUE 2230A * 11 SYMMETRICAL AMPLI ... 2230A H932351 1&2/2.. *

REPERE INDEXE	REF. ADRET PART NUMBER	DESCRIPTION	PART DESCRIPTION	FOURNISSEUR/PLAN SUPPLIER/DRAWING	QTE QTY
C -001	3700180000	22MMF/16V 5,08 ... STAND L TAG	* 22MMF/16V 5,08 ... STAND L TAG	STC	1
C -002	3700180000	22MMF/16V 5,08 ... STAND L TAG	* 22MMF/16V 5,08 ... STAND L TAG	STC	1
C -003	3700020000	1MMF/35V 5,08 ... STAND L TAG	* 1MMF/35V 5,08 ... STAND L TAG	STC	1
C -004	3700020000	1MMF/35V 5,08 ... STAND L TAG	* 1MMF/35V 5,08 ... STAND L TAG	STC	1
C -005	3120001800	18PF 2,5 'J' 2222 680 10 189	* 18PF 2,5 'J' 2222 680 10 189	COGECO	1
C -006	3150031000	10NF 5,08 63V GOX 767 14	* 10NF 5,08 63V GOX 767 14	LCC	1
C -007	3700180000	22MMF/16V 5,08 ... STAND L TAG	* 22MMF/16V 5,08 ... STAND L TAG	STC	1
C -008	3234100000	0,1MMF 10(10X250V)222236845104	* 0,1MMF 10(10X250V)222236845104	COGECO	1
C -009	3234100000	0,1MMF 10(10X250V)222236845104	* 0,1MMF 10(10X250V)222236845104	COGECO	1
C -010	3232330000	3300PF 10(10X400V)222236855332	* 3300PF 10(10X400V)222236855332	COGECO	1
C -011	3120095600	5,6PF 2,5'C' 2222 680 09 568	* 5,6PF 2,5'C' 2222 680 09 568	COGECO	1
D -001	4500310000	1 N 4448	* 1 N 4448	ITT	1
D -002	4500310000	1 N 4448	* 1 N 4448	ITT	1
Q -001	4300190000	BC550C /414C/413C/549C(BC184C)	* BC550C /414C/413C/549C(BC184C)	RTC	1
Q -002	4800060000	2N2219	* 2N2219	RTC	1
Q -003	4800080000	2N2905	* 2N2905	RTC	1
R -001	2500975000	75R0 * 1X 0,3 W SMA207	* 75R0 * 1X 0,3 W SMA207	DRALORIC	1
R -002	2210013300	330R 5X N4	* 330R 5X N4	SOVCOR	1
R -003	2500052300	523R * 1X 0,3 W SMA207	* 523R * 1X 0,3 W SMA207	DRALORIC	1
R -004	2500110000	1K00 * 1X 0,3 W SMA207	* 1K00 * 1X 0,3 W SMA207	DRALORIC	1
R -005	2210031500	15K 5X N4	* 15K 5X N4	SOVCOR	1
R -006	2210011000	100R 5X N4	* 100R 5X N4	SOVCOR	1
R -007	2210011000	100R 5X N4	* 100R 5X N4	SOVCOR	1
R -008	2210004700	47R 5X N4	* 47R 5X N4	SOVCOR	1
R -009	2210015600	560R 5X N4	* 560R 5X N4	SOVCOR	1
R -010	2210024700	4K7 5X N4	* 4K7 5X N4	SOVCOR	1
R -011	2210033900	39K 5X N4	* 39K 5X N4	SOVCOR	1
R -012	2210032200	22K 5X N4	* 22K 5X N4	SOVCOR	1
R -013	2210032200	22K 5X N4	* 22K 5X N4	SOVCOR	1
R -014	2210032200	22K 5X N4	* 22K 5X N4	SOVCOR	1
R -015	2300092200	2R2 SFR 25 1/4W 5X RC2T	* 2R2 SFR 25 1/4W 5X RC2T	RTC	1
R -016	2300092200	2R2 SFR 25 1/4W 5X RC2T	* 2R2 SFR 25 1/4W 5X RC2T	RTC	1
R -017	2500146400	4K64 * 1X 0,3 W SMA207	* 4K64 * 1X 0,3 W SMA207	DRALORIC	1
R -018	2500146400	4K64 * 1X 0,3 W SMA207	* 4K64 * 1X 0,3 W SMA207	DRALORIC	1
R -019	2500049900	499R * 1X 0,3 W SMA207	* 499R * 1X 0,3 W SMA207	DRALORIC	1
R -020	2500924900	24R9 * 1X 0,3 W SMA207	* 24R9 * 1X 0,3 W SMA207	DRALORIC	1
R -021	2210031000	10K 5X N4	* 10K 5X N4	SOVCOR	1
R -022	2210038200	82K 5X N4	* 82K 5X N4	SOVCOR	1
R -023	2500973200	73R2 * 1X 0,3 W SMA207	* 73R2 * 1X 0,3 W SMA207	DRALORIC	1
R -024	2500973200	73R2 * 1X 0,3 W SMA207	* 73R2 * 1X 0,3 W SMA207	DRALORIC	1
R -025	2500029400	294R * 1X 0,3 W SMA207	* 294R * 1X 0,3 W SMA207	DRALORIC	1
R -026	2500029400	294R * 1X 0,3 W SMA207	* 294R * 1X 0,3 W SMA207	DRALORIC	1
SN -001	4200330000	LM 318 N B+	* LM 318 N B+	NS	1
SN -002	4200090000	LM 741 CN B+ . DIP 8 PATTES	* LM 741 CN B+ . DIP 8 PINS	NS	1
Z1	1100010000	FIL NOIR	* BLACK THREAD	FILECA	0
Z1	1100030000	FIL ROUGE	* RED THREAD	FILECA	0
Z1	1100070000	FIL BLEU	* BLUE THREAD	FILECA	0
Z1	1100430000	COAX KX 21 A	* COAX KX 21 A	FILECA	0
Z1	1100530000	FIL.NJ.ETAME.6/10	* TINNED BARE THREAD 6/10	ELECTROFIL	0
Z1	1269120500	CI AMPLI	* PC AMPLI	K996912.....TM	1
Z1	1300590000	SOUPLISSO 0,6X0,9 COUL.NATUREL	* SPAGHETTI 0.6X0.9 GRAY COLORED	HABIA	0
Z4	4900060000	DISSIPATEUR	* DISSIPATOR	JERMYN	2
Z4	4900070000	ENTRETOISE T05	* SPACER T05	JERMYN	2
Z5	5500110000	TUBE B30 GT 4,1X2X12,5	* TUBE B30 GT 4,1X2X12,5	COFELEC	1
Z6	6400080000	RIVET D 1,5 L 2,4	* RIVET D 1.5 L 2.4	MFOM	1

 *0270080300 02 CHASSIS EQUIPE Z0 ... 2230A * 02 FITTED CHASSIS Z0 ... 2230A J910214..... *

REPERE INDEXE	REF. ADRET PART NUMBER	DESCRIPTION	PART DESCRIPTION	FOURNISSEUR/PLAN SUPPLIER/DRAWING	QTE QTY
001	0269150100	07 PORTEUR EQUIPE	2230A * 07 FITTED MOTHER BD	2230A B920953.A976915	1
001	0270110000	08 PLAQUE AVANT MONTEE ..	2230A * 08 ASSEM. FRONT PLATE ..	2230A L920934.....	1
001	0270940000	01 AMPLI Z=0	2230A * 01 AMPLI Z=0	2230A E932549.A977094	1
Z0	0270130000	03 MATTE 26'171'177'L140	2230 * 03 FLAT-T.26'171'177'L140	2230 ADRET.....	1
Z0	0271050000	03 MATTE 26'171'177'L190	2230 * 03 FLAT-T.26'171'177'L190	2230 ADRET.....	1
Z1	1000270000	ALIMENTATION	2230A * POWER SUPPLY	2230A E932214.....	1
Z1	1100010000	FIL NOIR	KY30-04 * BLACK THREAD	KY30-04 FILECA	0
Z1	1100020000	FIL MARRON	KY30-04 * BROWN THREAD	KY30-04 FILECA	0
Z1	1100030000	FIL ROUGE	KY30-04 * RED THREAD	KY30-04 FILECA	0
Z1	1100040000	FIL ORANGE	KY30-04 * ORANGE THREAD	KY30-04 FILECA	0
Z1	1100060000	FIL VERT	KY30-04 * GREEN THREAD	KY30-04 FILECA	0
Z1	1100070000	FIL BLEU	KY30-04 * BLUE THREAD	KY30-04 FILECA	0
Z1	1100080000	FIL VIOLET	KY30-04 * PURPLE THREAD	KY30-04 FILECA	0
Z1	1100090000	FIL GRIS	KY30-04 * GREY THREAD	KY30-04 FILECA	0
Z1	1100430000	COAX KX 21 A * COAX KX 21 A FILECA	1
Z1	1100440000	CABLE BLINDE GRIS	FMA2R * GREY ARMORED CABLE	FMA2R FILECA	0
Z1	1100450000	CABLE BLINDE GRIS	FMA4R * GREY ARMORED CABLE	FMA4R FILECA	0
Z1	1100520000	FIL NU. ETAME. 4/10 * TINNED BARE THREAD 4/10 ELECTROFIL	0
Z1	1100950000	VERT/JAUNE .. HO7-U-K(1X1.5ET) * GREEN/YELLOW HO7-U-K(1X1.5ET) FILECA	1
Z1	1300080000	COLLIER	REF H3P * COLLAR	REF H3P HELLERMANN	1
Z1	1300090000	COLLIER	REF H4P * COLLAR	REF H4P HELLERMANN	3
Z1	1300450000	GAINE F4,8 FP301 3/16 ..	SFM 48 * SHEATH F4.8 FP301 3/16 ..	SFM 48 HELLERMANN	0
Z1	1300460000	GAINE F6,4 FP301 1/4 ..	SFM 64 * SHEATH F6.4 FP301 1/4 ..	SFM 64 HELLERMANN	0
Z1	1300540000	LACING	REF T2 UP NOIR * LACING	REF T2 UP NOIR HELLERMANN	1
Z1	1300590000	SOUPLISSO 0.6X0.9 COUL. NATUREL * SPAGHETTI 0.6X0.9 GRAY COLORED	HABIA	5
Z1	1400200500	BMC EMBASE 'FEMEL' ECRou R141557 * BMC FEMALE SOCKET NUT R141557	RADIALL	0
Z1	1405000900	EMBASE DIN ... LUMBERG REF B51 * DIN SOCKET ... LUMBERG REF B51	LIENARD SOVAL	1
Z1	1410007700	TB 10 F * TB 10 F	FEMALE TREClec	1
Z1	1530202000	INVERSEUR REF:0391584-710 NOIR * REVERSER REF:0391584-710 BLACK	METALLO	1
Z1	1530208400	INVERSEUR ... REF:039-1584-110 * REVERSER ... REF:039-1584-110	METALLO	1
Z1	1700340000	FILTRE 220V+NEUTRE 3A P. EUROPE * FILTER 220V+NEUTRAL 3A P. EUROPE	EUROPAVIA	1
Z1	1710003900	PORTE FUSIBLE D5406 031-1603 * FUSE BLOCK D5406 031-1603	ARNOULD	1
Z1	1710004000	TETE 6.3X32(17100039) 031-1613 * HEAD 6.3X32(17100039) 031-1613	ARNOULD	1
Z1	1720004900	160MA	FST6332 034-3409 * 160MA	FST6332 034-3409 ARNOULD	1
Z1	1900180000	GUIDE CARTE ANTIUIBR. REF R221 * BOARD GUIDE	REF R221 TREClec	10
Z4	4200220000	7806 UC REGUL.6V/1A	T0220 * 7806 UC REGUL.6V/1A	T0220 FAIRCHILD	1
Z4	4200280000	7812 UC REGUL.12V/1A TO 220 * 7812 UC REGUL.12V/1A TO 220	FAIRCHILD	1
Z4	4200290000	MC 7912 CP REGUL.-12V/1A T0220 * MC 7912 CP REGUL.-12V/1A T0220	MOTOROLA	1
Z4	4500310000	I N 4448 * I N 4448	ITT	1
Z4	4900130000	CALE TO 220 REF:AY537-490537 * MICA QUIN FOR TO 220 REF C75	GETELEC	3
Z4	4900220000	CANON ISOLANT TO 220 EPAUL.3,5 * INSULATING CANNON 220 EP. 3.5	MOTOROLA	3
Z5	5500110000	TUBE B30 GT 4.1X2X12.5 * TUBE B30 GT 4.1X2X12.5	COFELEC	7
Z6	6100030600	TCB M3X 6 U DIN7985-4,8 INOX * TCB M3X 6 U DIN7985-4,8 INOX	BD	20
Z6	6100030800	TCB M3X 8 U DIN7985-4,8 INOX * TCB M3X 8 U DIN7985-4,8 INOX	BD	14
Z6	6100031200	TCB M3X12 U DIN7985-4,8 INOX * TCB M3X12 U DIN7985-4,8 INOX	BD	6
Z6	6101032000	TF/90 M3X20 U DIN965-4,8 INOX * TF/90 M3X20 U DIN965-4,8 INOX	BD	3
Z6	6101040600	ACF 4 X 6 FRAISEE F/90 CRUCIF * ACF 4 X 6 FRAISEE F/90 CRUCIF	SAGIC	4
Z6	6107020600	TCL 2.2X6.5 POINT.DIN7981BINOX * TCL 2.2X6.5 NIBBL.DIN7981BINOX	BD	6
Z6	6200030000	ECROU H M3 U NF E27-411-5 INOX * NUT H M3 U NF E27-411-5 INOX	BD	11
Z6	6300030000	Z 3U (6X0,8) NF E27-611 INOX * Z 3U (6X0,8) NF E27-611 INOX	BD	3
Z6	6300030100	M 3U (8X0,8) NF E27-611 INOX * INOX M3 X 8X0.8 FLAT ...	MEAN BD	8
Z6	6305030000	ACI 3 CONTACT REF 55-03-01 * STEEL 3 CONTACT REF 55-03-01	NOMEL	8
Z6	6400040000	RIVET D 3 L 5 REF 3050 * RIVET D 3 L 5 REF 3050	MFOM	4
Z6	6400160000	COSSE A SOUDER 3,2	519 * SOLDERING TERMINAL 3.2 ...	519 MFOM	1
Z6	6400350000	COSSE A SOUDER	2003E * SOLDERING TERMINAL	2003E MFOM	5
Z6	6400510000	EQUERRE 10X10 LARG 10 EP 1 * ANGLEBRACKET10X10 WIDTH10 EP 1	A943051	4
Z6	6400540000	RIVET POP 2,4 L 5 ALU AD32-ABS * POP RIVET 2.4 L 5 ALU AD32-ABS	MFOM	24
Z6	6400780000	RIVET D 20 L 4 * RIVET D 20 L 4	MFOM	20
Z8	8006703600	PANNEAU ARRIERE 1MHZ ...	2230A * 1MHZ REAR PANEL	2230A E932706.B932451	1
Z8	8006710100	CLOISON DE CARTE	2230A * BOARD DIVISION	2230A A932170	3
Z8	8006721600	GLISSIERE HABILLAGE	2230A * LAGGING SLIDEWAY	2230A C932358	2
Z8	8006722900	RADIATEUR CARRE 12	2230A * SQUARE 12 DISSIPATOR ...	2230A A942290	1
Z8	8106711300	FLASQUE LAT. CHASSIS ...	2230A * CHASSIS LAT. FLASK	2230A F920846	2

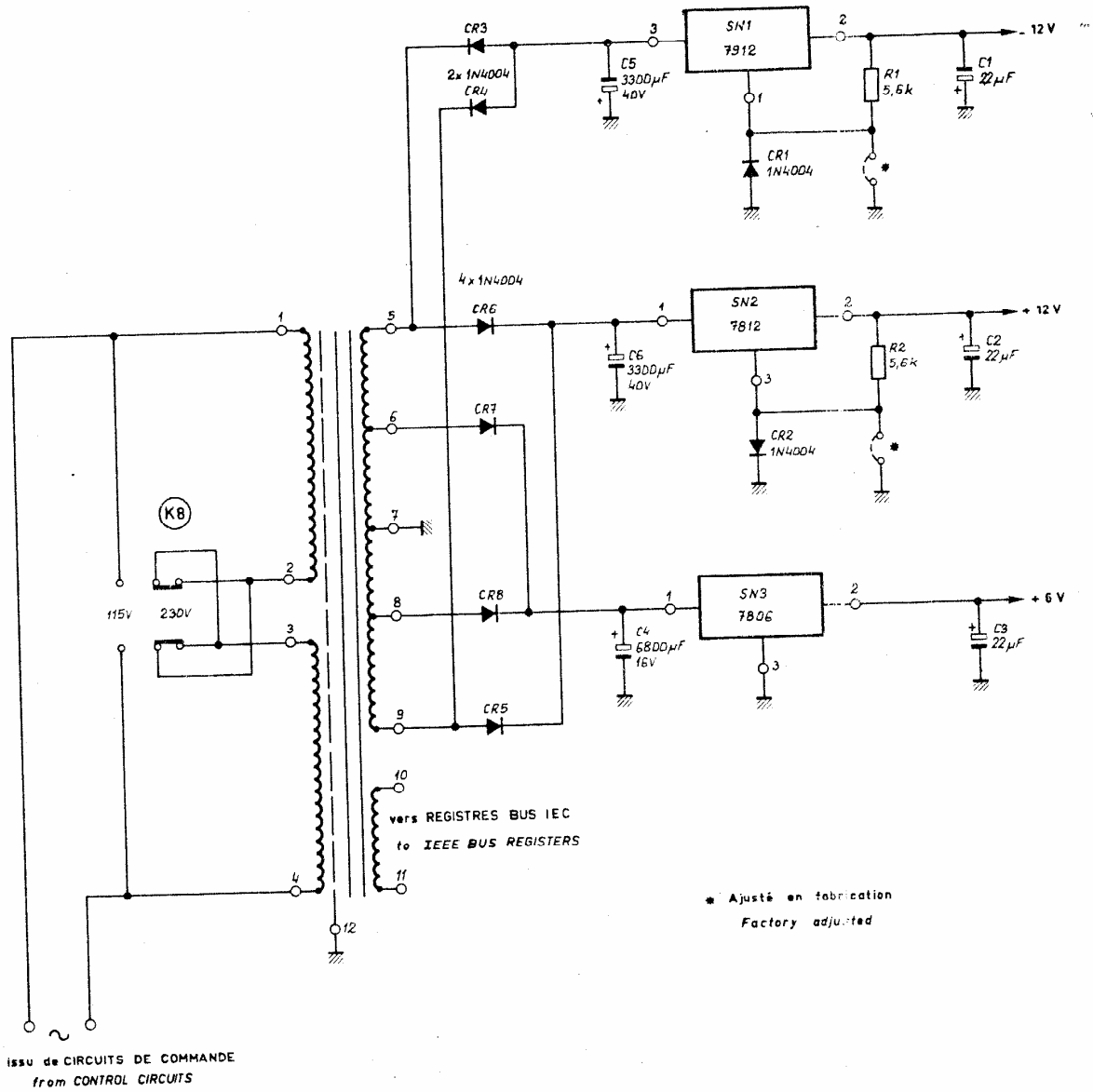

PLATE V-8
PLANCHE V-8

Le dessinateur se porte responsable de l'exactitude des données			edrat électronique		DATE: JUILLET 1978
ETUDIE	DESSINE	VERIFIE	2230 A ALIMENTATION POWER SUPPLY		PAGE: 1 / 1
ACORT	H.K.				976915A

REPERE INDEXE	REF. ADRET PART NUMBER	DESCRIPTION	PART DESCRIPTION	FOURNISSEUR/PLAN SUPPLIER/DRAWING	QTE QTY
C -001	3700180000	22MMF/16V 5,08 ... STAND L TAG	* 22MMF/16V 5,08 ... STAND L TAG	STC	1
C -002	3700180000	22MMF/16V 5,08 ... STAND L TAG	* 22MMF/16V 5,08 ... STAND L TAG	STC	1
C -003	3700180000	22MMF/16V 5,08 ... STAND L TAG	* 22MMF/16V 5,08 ... STAND L TAG	STC	1
C -004	3500430000	6800MMF 16V RELSIC 033	* 6800MMF 16V RELSIC 033	SIC SAFCO	1
C -005	3500440000	3300MMF 40V RELSIC 033	* 3300MMF 40V RELSIC 033	SIC SAFCO	1
C -006	3500440000	3300MMF 40V RELSIC 033	* 3300MMF 40V RELSIC 033	SIC SAFCO	1
D -001	4500040000	1N4004	* 1N4004	ITT	1
D -002	4500040000	1N4004	* 1N4004	ITT	1
D -003	4500040000	1N4004	* 1N4004	ITT	1
D -004	4500040000	1N4004	* 1N4004	ITT	1
D -005	4500040000	1N4004	* 1N4004	ITT	1
D -006	4500040000	1N4004	* 1N4004	ITT	1
D -007	4500040000	1N4004	* 1N4004	ITT	1
D -008	4500040000	1N4004	* 1N4004	ITT	1
D -009	4500310000	1 N 4448	* 1 N 4448	ITT	1
D -010	4500310000	1 N 4448	* 1 N 4448	ITT	1
D -011	4500310000	1 N 4448	* 1 N 4448	ITT	1
D -012	4500310000	1 N 4448	* 1 N 4448	ITT	1
D -013	4500310000	1 N 4448	* 1 N 4448	ITT	1
D -014	4500310000	1 N 4448	* 1 N 4448	ITT	1
D -015	4500310000	1 N 4448	* 1 N 4448	ITT	1
D -016	4500310000	1 N 4448	* 1 N 4448	ITT	1
D -017	4500310000	1 N 4448	* 1 N 4448	ITT	1
D -018	4500310000	1 N 4448	* 1 N 4448	ITT	1
D -019	4500310000	1 N 4448	* 1 N 4448	ITT	1
D -020	4500310000	1 N 4448	* 1 N 4448	ITT	1
D -021	4500310000	1 N 4448	* 1 N 4448	ITT	1
D -022	4500310000	1 N 4448	* 1 N 4448	ITT	1
D -023	4500310000	1 N 4448	* 1 N 4448	ITT	1
D -024	4500310000	1 N 4448	* 1 N 4448	ITT	1
D -025	4500310000	1 N 4448	* 1 N 4448	ITT	1
D -026	4500310000	1 N 4448	* 1 N 4448	ITT	1
D -027	4500310000	1 N 4448	* 1 N 4448	ITT	1
D -028	4500310000	1 N 4448	* 1 N 4448	ITT	1
R -001	2210025600	5K6 5% N4	* 5K6 5% N4	SOUCOR	1
R -002	2210025600	5K6 5% N4	* 5K6 5% N4	SOUCOR	1
Z1	1100520000	FIL.NU.ETAME.4/10	* TINNED BARE THREAD 4/10	ELECTROFIL	0
Z1	1100540000	FIL.NU.ETAME.8/10	* TINNED BARE THREAD 8/10	ELECTROFIL	0
Z1	1269150600	CI PORTEUR 2230A	* PC MOTHER 2230A	E996915	1
Z1	1300950000	EMBASE (TY-RAP) .. REF LPMM-S5	* SOCKET (TY-RAP) .. REF LPMM-S5	PANDUIT	3
Z1	1300960000	TY-RAP L 142MM REF PLT 1.5M	* TY-RAP L 142MM REF PLT 1.5M	PANDUIT	3
Z1	1417030000	17PTS .EMEL. 6823-17-64-14-335	* 17PTS .EMEL. 6823-17-64-14-335	SOURIAU	1
Z1	1423029600	23PTS FEMEL. 8623-23-64-14-335	* 23PTS FEMAL. 8623-23-64-14-335	SOURIAU	1
Z1	1427030100	27PTS FEMEL. 8623-27-64-14-335	* 27PTS FEMALE 8623-27-64-14-335	SOURIAU	3
Z1	1435030200	35PTS FEMEL. 8623-35-64-14-335	* 35PTS FEMALE 8623-35-64-14-335	SOURIAU	1
Z6	6400020000	RIVET D 2.2 L 3.7 2237..2035	* RIVET D 2.2 L 3.7 2237..2035	MFOM	7
Z6	6400030000	RIVET D 3 L 4.2 3042	* RIVET D 3 L 4.2 3042	MFOM	3
Z6	6400060000	RIVET D 1.2 L 2.4 XC 39	* RIVET D 1.2 L 2.4 XC 39	MFOM	8
Z6	6400270000	PLOT A FOURCHE SERTI BFM13-16	* SQUEEZED FORK CONTACT BFM13-16	COMATEL	7
Z6	6400280000	PLOT A FOURCHE SOUDE . BFMQ13C	* SOLDERED FORK CONTACT BFMQ13C	COMATEL	13

REPERE INDEXE	REF. ADRET PART NUMBER	DESCRIPTION	PART DESCRIPTION	FOURNISSEUR/PLAN SUPPLIER/DRAWING	QTE QTY
001	0269090000	03 COMMUTATEUR TTL 2230A	* 03 TTL SWITCH	2230A D932366.....	1
001	0270030100	09 COMMUTATEUR MODE 2230A	* 09 MODE SWITCH	2230A J932523.B977003	1
001	0270100000	04 BLOC ROUES CODEES ... 2230A	* 04 SPIN WHEELS BLOCK ...	2230A D920933.....	1
Z0	0206500000	00 NATTE 16'137''137'L190	* 00 FLAT-TOP 16'137''137'L190	ADRET.....	1
Z1	1100010000	FIL NOIR	* BLACK THREAD	KY30-04 FILECA	0
Z1	1100020000	FIL MARRON	* BROWN THREAD	KY30-04 FILECA	0
Z1	1100030000	FIL ROUGE	* RED THREAD	KY30-04 FILECA	0
Z1	1100040000	FIL ORANGE	* ORANGE THREAD	KY30-04 FILECA	0
Z1	1100050000	FIL JAUNE	* YELLOW THREAD	KY30-04 FILECA	0
Z1	1100060000	FIL VERT	* GREEN THREAD	KY30-04 FILECA	0
Z1	1100070000	FIL BLEU	* BLUE THREAD	KY30-04 FILECA	0
Z1	1100080000	FIL VIOLET	* PURPLE THREAD	KY30-04 FILECA	0
Z1	1100090000	FIL GRIS	* GREY THREAD	KY30-04 FILECA	0
Z1	1100100000	FIL BLANC	* WHITE THREAD	KY30-04 FILECA	0
Z1	1100110000	FIL ROSE	* PINK THREAD	KY30-04 FILECA	0
Z1	1100400000	CABLE BLINDE GRISFMA2R	* GREY ARMORED CABLE	FMA2R FILECA	0
Z1	1100530000	FIL NU. ETAME. 6/10	* TINNED BARE THREAD 6/10	ELECTROFIL	0
Z1	1300050000	RELAIS REF 1072 K	* RELAYS REF 1072 K	ATI	1
Z1	1300450000	GAINÉ F4,8 FP301 3/16 . SFM 48	* SHEATH F4.8 FP301 3/16 . SFM 48	HELLERMANN	0
Z1	1300460000	GAINÉ F6,4 FP301 1/4 . SFM 64	* SHEATH F6.4 FP301 1/4 . SFM 64	HELLERMANN	0
Z1	1300590000	SOUPLISSÉ 0,6X0,9 COUL. NATUREL	* SPAGHETTI 0.6X0.9 GRAY COLORED	HABIA	0
Z1	1400290500	BNC EMBASE FEMEL ECROU R141557	* BNC FEMALE SOCKET NUT R141557	RADIALL	1
Z1	1700020000	LUCIOLE M.MIDJET AN643 5U/75MA	* BRIGHT FIREFLY .AN643 5U/75MA	MAZDA	1
Z2	2122500500	4K7/10K LIN PK16-DCS 3X32+6X16	* 4K7/10K LIN PK16-DCS 3X32+6X16	MCB COUPER 3X26	1
Z4	4000010000	LED ROUGE '5' ... REF CQV 20-4	* RED LED '5' ... REF CQV 20-4	SIEMENS	2
Z4	4000060000	LED VERTE '5' ... REF CQV 25-6	* GREEN LED '5' ... REF CQV 25-6	SIEMENS	1
Z4	4000070000	LED JAUNE '5' ... REF CQV 23-6	* YELLOW LED '5' ... REF CQV 23-6	SIEMENS	3
Z4	4000140000	LED 5 SUPPORT REF HLHP-0103	* BASE 5 LED ... REF HLHP-0103	HP	6
Z4	4900180000	BRIDE DIP-LOCK CA 16 200 DL	* BRIDLE DIP-LOCK CA 16 200 DL	EUROPAUTA	1
Z5	5500110000	TUBE B30 GT 4,1X2X12,5	* TUBE B30 GT 4.1X2X12.5	COFELEC	1
Z6	6101031200	TF/90 M3X12 U DIN965-4,8 INOX	* TF/90 M3X12 U DIN965-4,8 INOX	BD	4
Z6	6101110400	TF M2,5X 4 U NFE27-113-5,6INOX	* TF M2,5X 4 U NFE27-113-5,6INOX	BD	1
Z6	6131120600	LAD 2 X 6 FRAISEE F/90 FENDUE	* LAD 2 X 6 FRAISEE F/90 FENDUE	SAGIC	10
Z6	6200020000	ECROU H M2 U NF E27-411-5 INOX	* NUT H M2 U NF E27-411-5 INOX	BD	8
Z6	6200030000	ECROU H M3 U NF E27-411-5 INOX	* NUT H M3 U NF E27-411-5 INOX	BD	4
Z6	6301020000	DI 2 EVENTAIL NFE 27-618 INOX	* STEEL 2 FAN NFE 27-618 INOX	BD	8
Z6	6305030000	ACI 3 CONTACT REF 55-03-01	* STEEL 3 CONTACT REF 55-03-01	NOMEL	4
Z6	6360011000	BAK 2,6X 5X 1 PLATE 100A	* BAK 2.6X 5X 1 PLATE 100A	MFOM	1
Z6	6400160000	COSSE A SOUDER 3,2 519	* SOLDERING TERMINAL 3.2 ... 519	MFOM	1
Z6	6400350000	COSSE A SOUDER 2003E	* SOLDERING TERMINAL 2003E	MFOM	1
Z6	6701240000	ENLIS 2 L 4	* ENLIS 2 L 4	ACCEL	4
Z6	6900300000	SCOTCH ELECTRIQUE 19MM REF 33	* ELECTRICAL SCOTCH 19MM REF 33	3M	0
Z6	6900320000	COLLE CYANILIT.....REF:IS496	* CYANALIT GLUE.....REF:IS496	FIV	4
Z8	8006710500	PLAQUE AVANT CHASSIS ... 2230A	* CHASSIS FRONT PLATE 2230A	E932265	1
Z8	8006740700	DIFFUSEUR CADRAN FREQU. 2230A	* FREQUENCY DIAL DIFFUSER 2230A	A942239	1

REPERE INDEXE	REF. ADRET PART NUMBER	DESCRIPTION	PART DESCRIPTION	FOURNISSEUR/PLAN SUPPLIER/DRAWING	QTE QTY
C -001	3700180000	22MMF/16V 5,08 ... STAND L TAG	* 22MMF/16V 5,08 ... STAND L TAG	STC	1
C -002	3700180000	22MMF/16V 5,08 ... STAND L TAG	* 22MMF/16V 5,08 ... STAND L TAG	STC	1
D -001	4500310000	1 N 4448	* 1 N 4448	ITT	1
K -001	1520512400	05 TOUCHES ORE 10 .TTL. 2230A	* 05 TOUCHES ORE 10 .TTL. 2230A	C932473	1
R -001	2210012200	220R	5% N4 * 220R	5% N4 SOUCOR	1
R -002	2210021200	1K2	5% N4 * 1K2	5% N4 SOUCOR	1
R -003	2210016800	680R	5% N4 * 680R	5% N4 SOUCOR	1
R -004	2210023300	3K3	5% N4 * 3K3	5% N4 SOUCOR	1
R -005	2210005100	51R	5% N4 * 51R	5% N4 SOUCOR	1
R -006	2210002200	22R	5% N4 * 22R	5% N4 SOUCOR	1
R -007	2210002200	22R	5% N4 * 22R	5% N4 SOUCOR	1
Z1	1269090300	CI COMMUTATEUR TTL 2230A	* PC TTL SWITCHER 2230A	D996909	1
Z6	6400280000	PLOT A FOURCHE SOUDE . BFMQ13C	* SOLDERED FORK CONTACT BFMQ13C	COMATEL	2
Z8	8006763200	TOUCHE GRISE D6H11 OREOR 2230A	* GREY TOUCH D6H11 OREOR 2230A	A942431	5

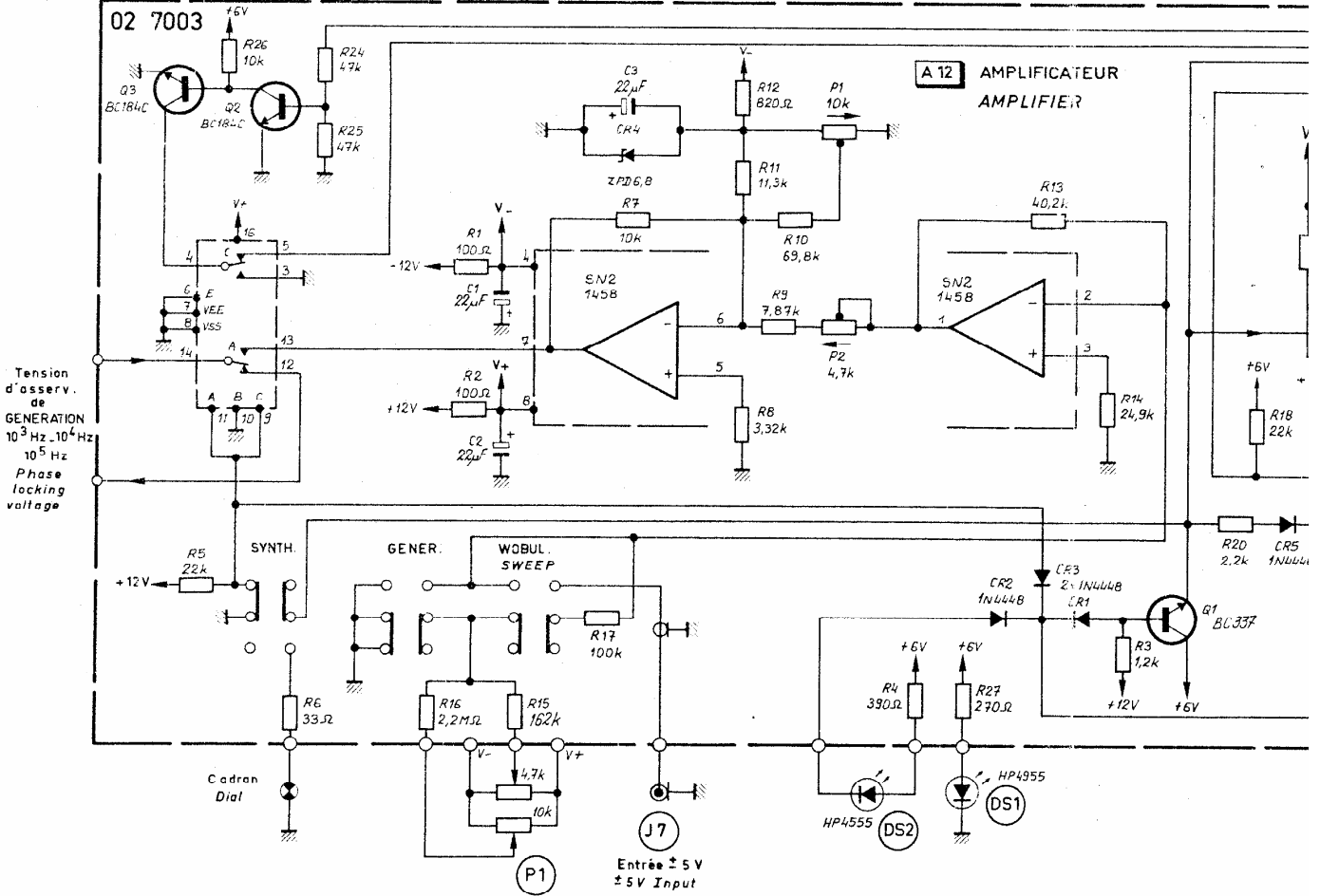
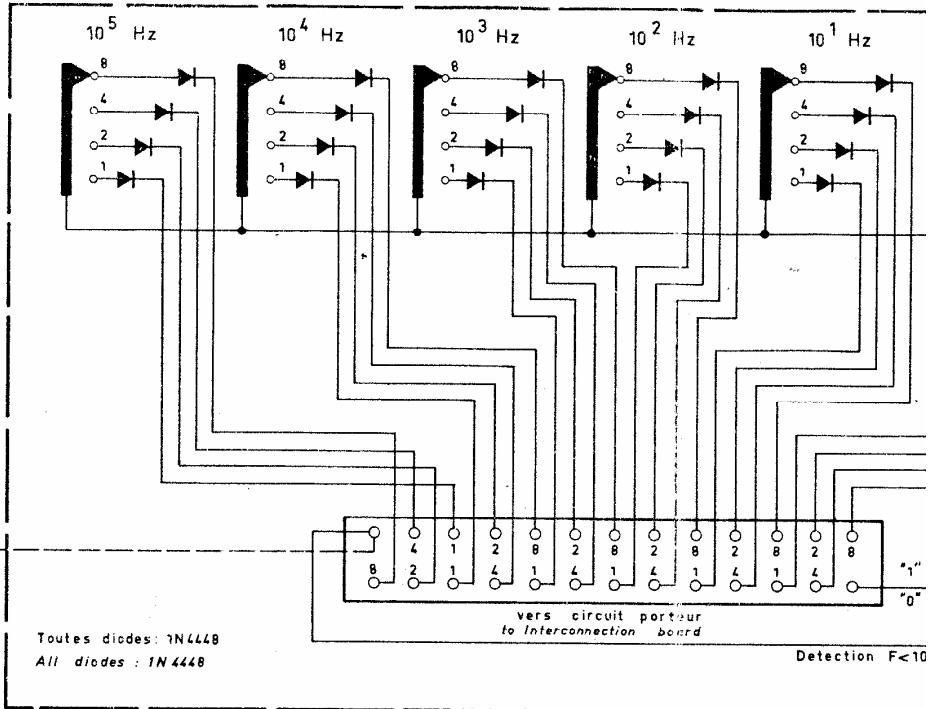
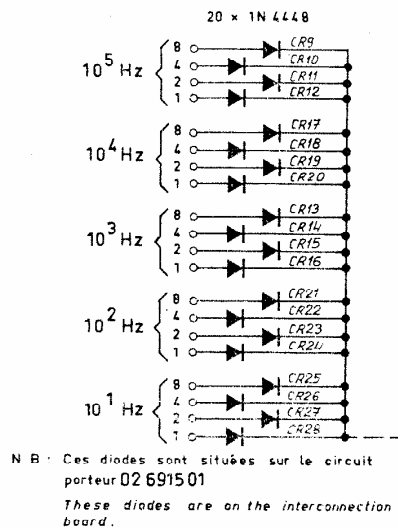

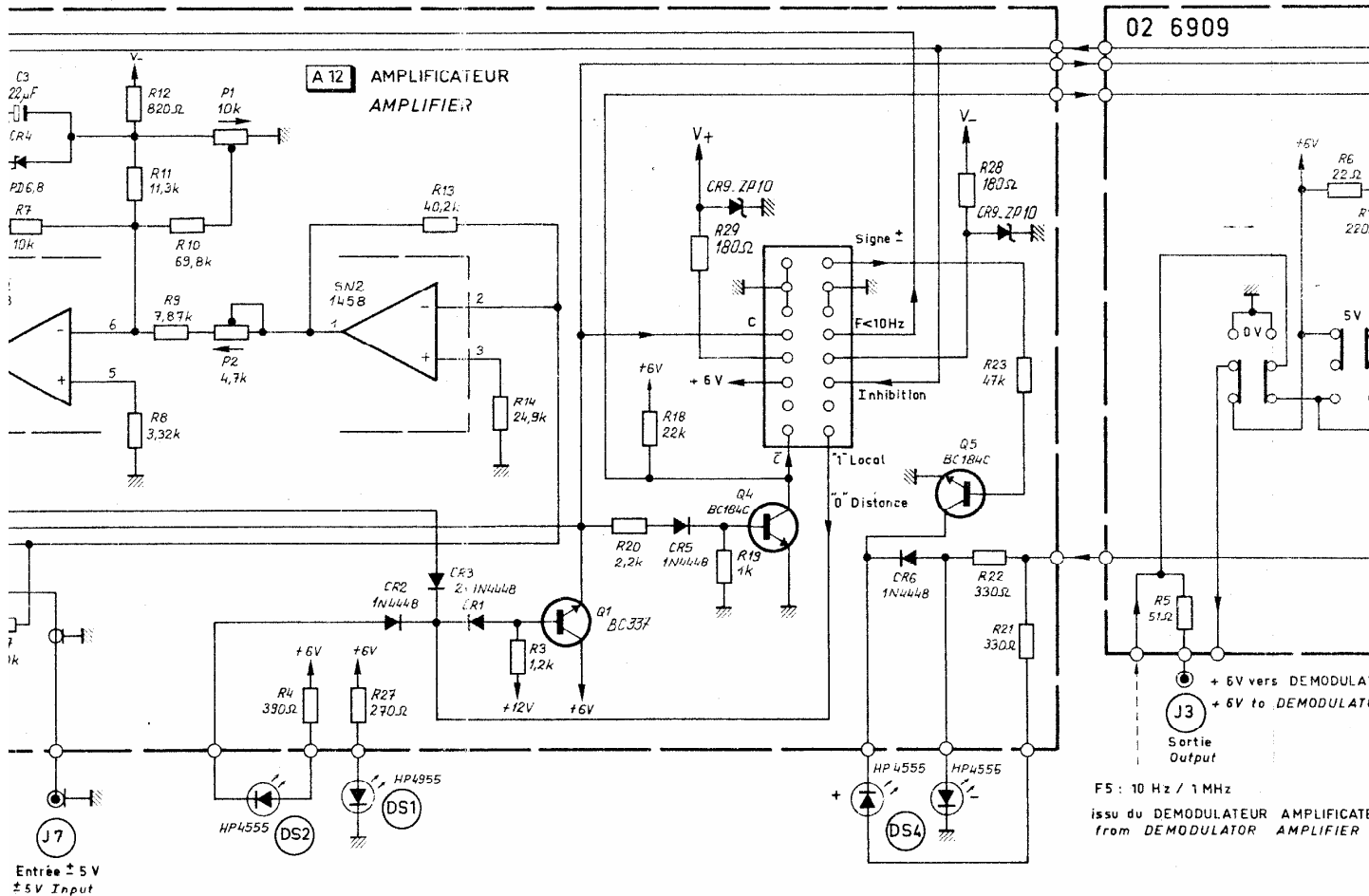
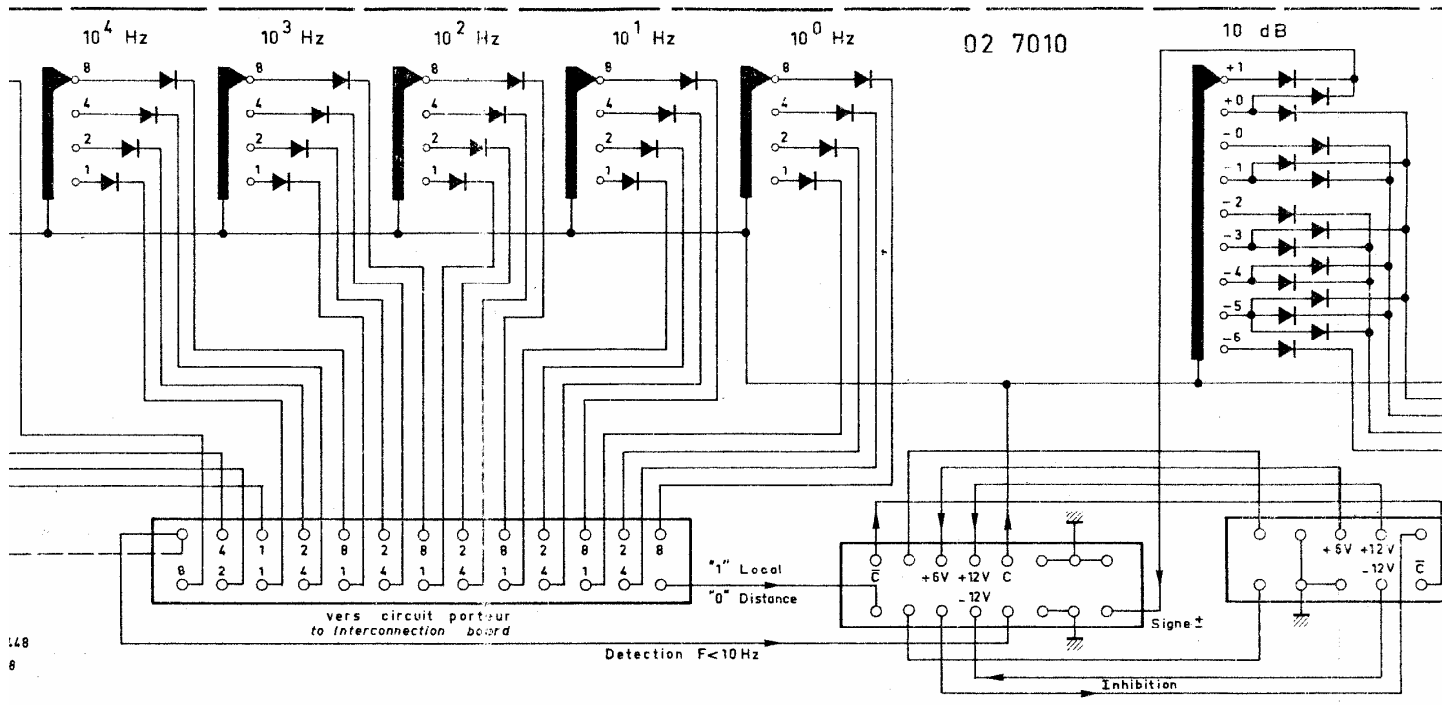

Ce document ne peut être reproduit sans autorisation de l'ETUDE DESIGN ACOR

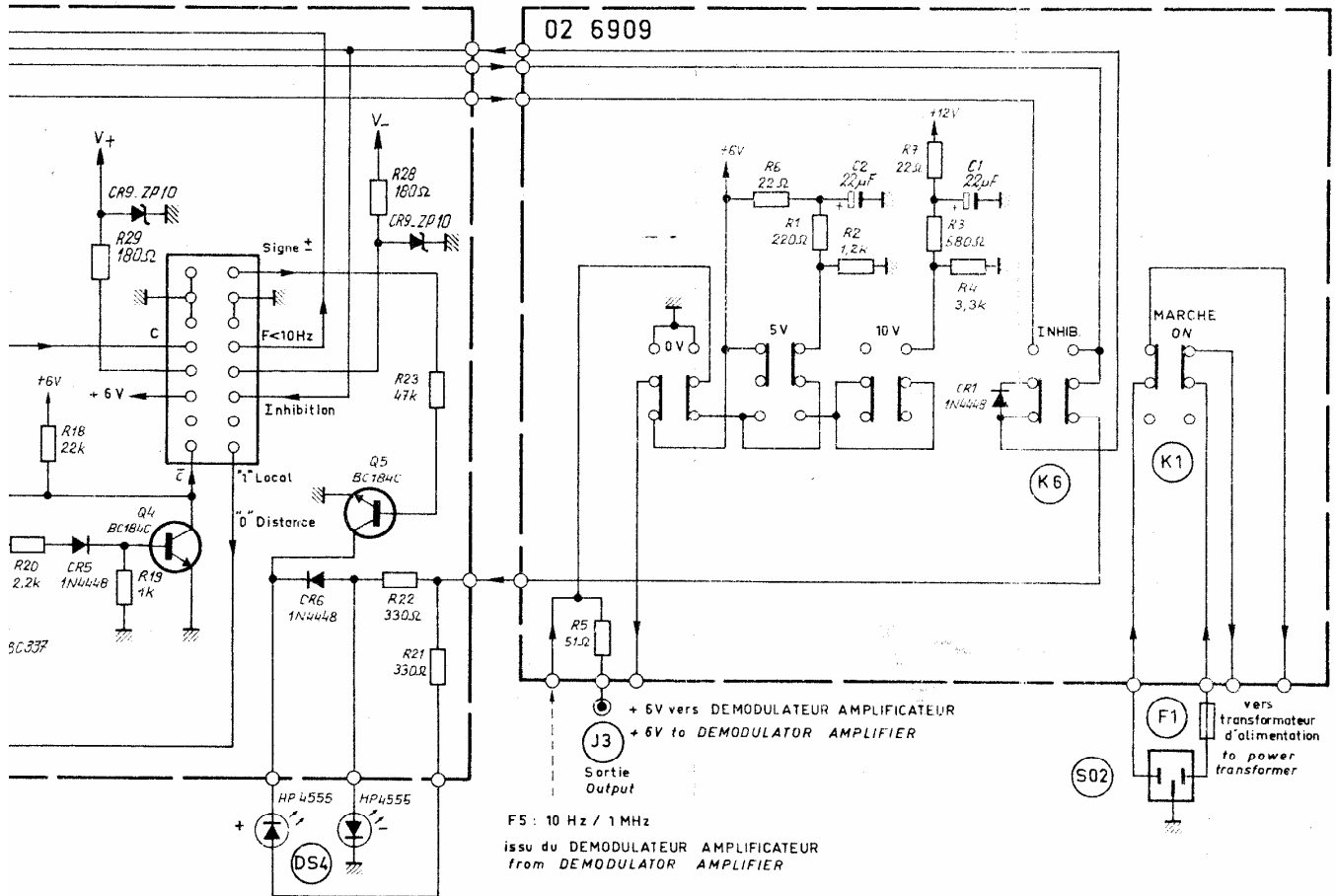
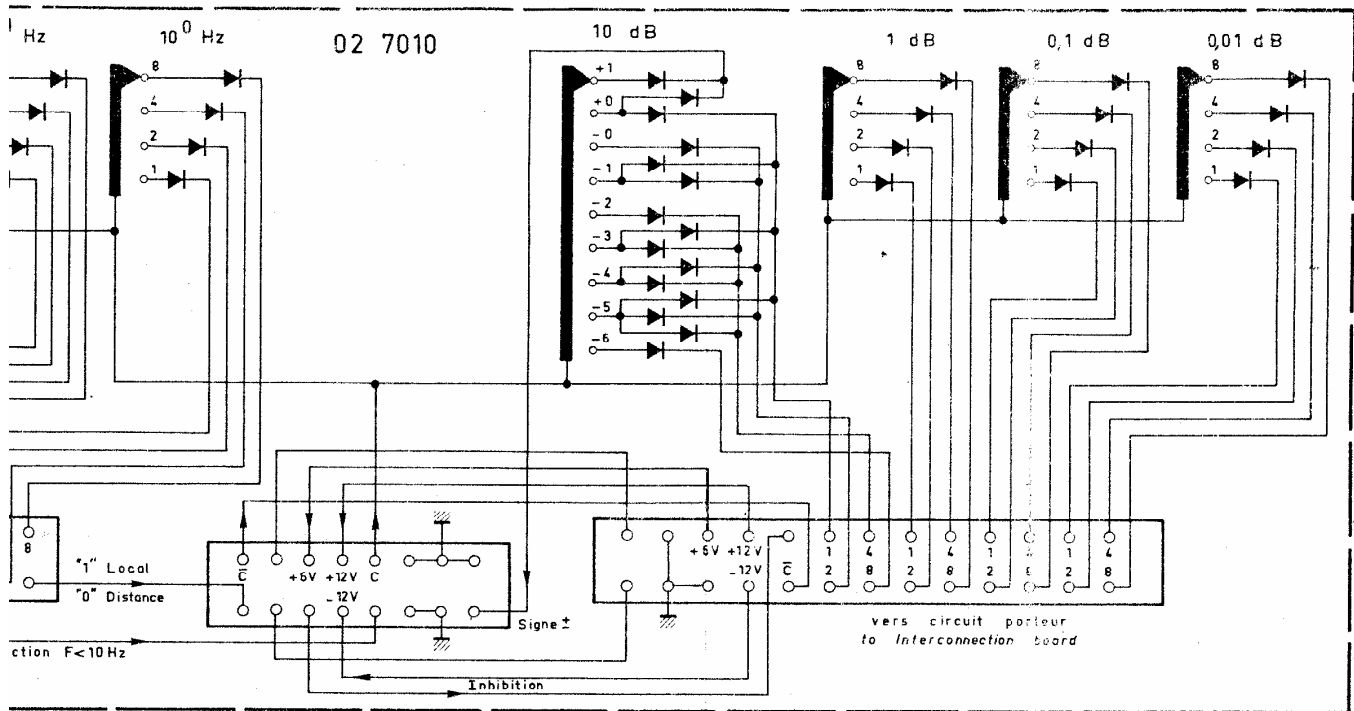

Ce document ne peut être communiqué ni reproduit sans autorisation		adret électronique	DATE: JUILLET 1978
ÉTUDE	DESSIN	VERIFIE	
ACORT	H.V.		
2230 A CIRCUITS DE COMMANDE CONTROL CIRCUITS			PAGE: 1 / 1
			977003B

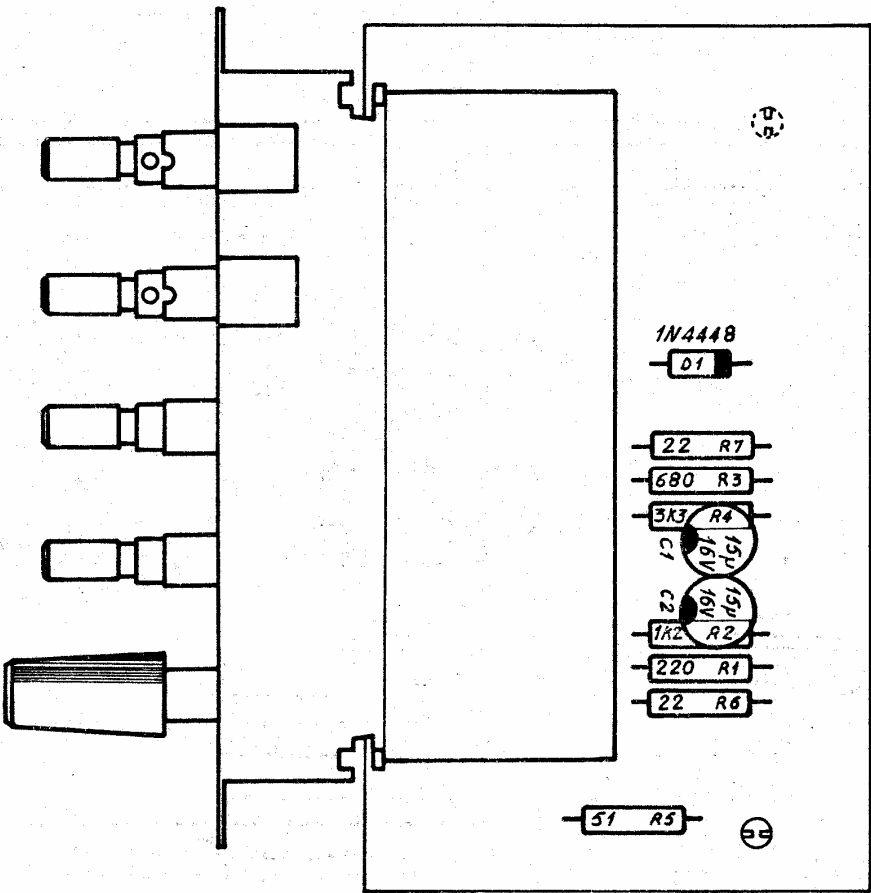

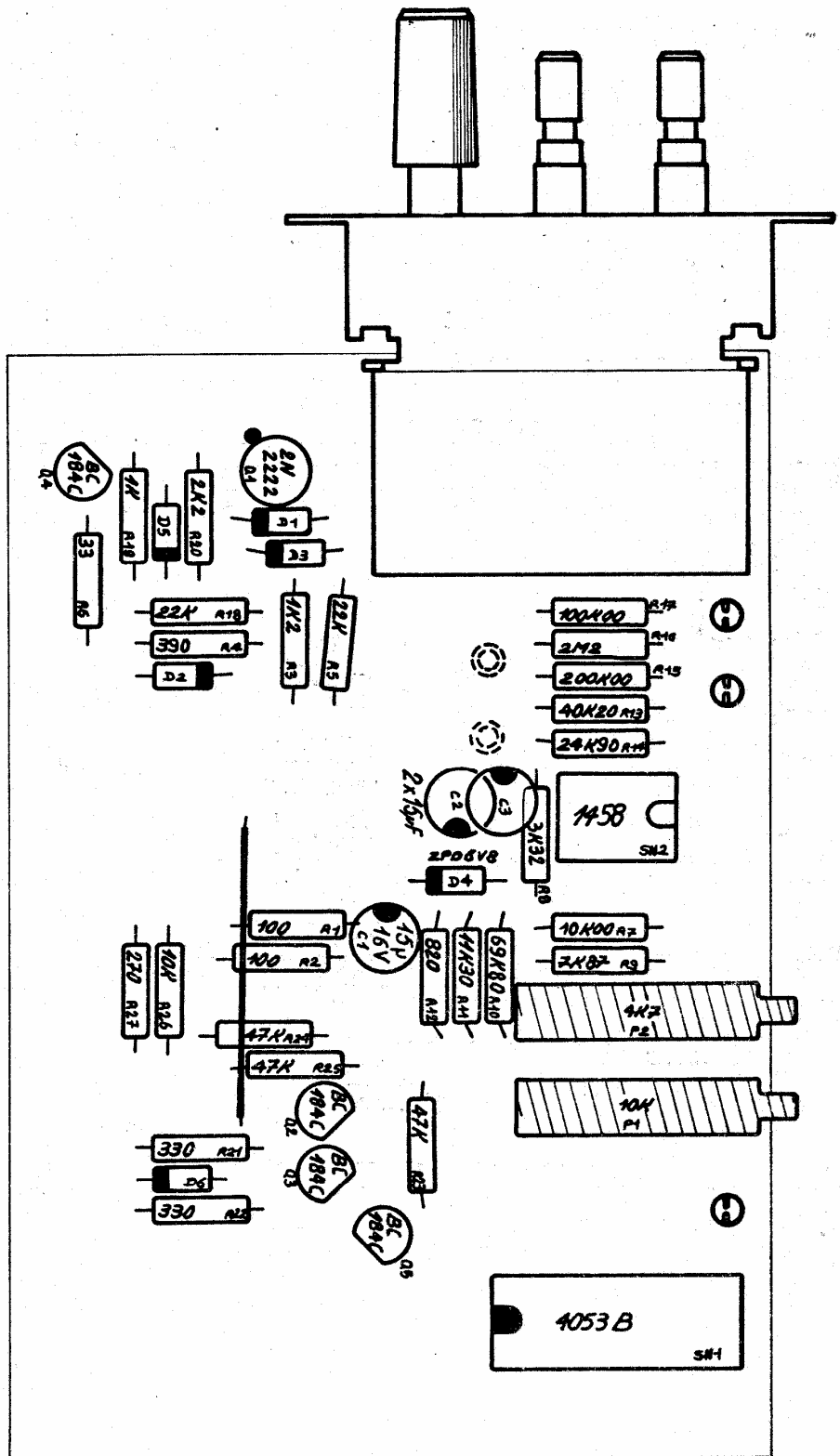

REPERE INDEXE	REF. ADRET PART NUMBER	DESCRIPTION	PART DESCRIPTION	FOURNISSEUR/PLAN SUPPLIER/DRAWING	QTE QTY
C	-001	3700180000 22MMF/16V 5,08 ... STAND L TAG	* 22MMF/16V 5,08 ... STAND L TAG	STC	1
C	-002	3700180000 22MMF/16V 5,08 ... STAND L TAG	* 22MMF/16V 5,08 ... STAND L TAG	STC	1
C	-003	3700180000 22MMF/16V 5,08 ... STAND L TAG	* 22MMF/16V 5,08 ... STAND L TAG	STC	1
D	-001	4500310000 1 N 4448	* 1 N 4448	ITT	1
D	-002	4500310000 1 N 4448	* 1 N 4448	ITT	1
D	-003	4500310000 1 N 4448	* 1 N 4448	ITT	1
D	-004	4600080000 ZPD6,8	* ZPD6,8	ITT	1
D	-005	4500310000 1 N 4448	* 1 N 4448	ITT	1
D	-006	4500310000 1 N 4448	* 1 N 4448	ITT	1
D	-007	4600170000 ZPD 10	* ZPD 10	ITT	1
D	-008	4600170000 ZPD 10	* ZPD 10	ITT	1
K	-001	1520312200 03 TOUCHES ORE 10 .MODE. 2230A	* 03 TOUCHES ORE 10 .MODE. 2230A	C932471	1
P	-001	2133100000 10K 3/4" 15T CERMET 43 P	* 10K 3/4" 15T CERMET 43 P	SPECTROL	1
P	-002	2132470000 4K7 3/4" 15T CERMET 43 P	* 4K7 3/4" 15T CERMET 43 P	SPECTROL	1
Q	-001	4300580000 BC 337-25 TO 92 (2N2222)	* BC 337-25 TO 92 (2N2222)	ITT	1
Q	-002	4300190000 BC550C /414C/413C/549C(BC184C)	* BC550C /414C/413C/549C(BC184C)	RTC	1
Q	-003	4300190000 BC550C /414C/413C/549C(BC184C)	* BC550C /414C/413C/549C(BC184C)	RTC	1
Q	-004	4300190000 BC550C /414C/413C/549C(BC184C)	* BC550C /414C/413C/549C(BC184C)	RTC	1
Q	-005	4300190000 BC550C /414C/413C/549C(BC184C)	* BC550C /414C/413C/549C(BC184C)	RTC	1
R	-001	2210006800 68R	* 68R	5% N4 SOUCOR	1
R	-002	2210011000 100R	* 100R	5% N4 SOUCOR	1
R	-003	2210021200 1K2	* 1K2	5% N4 SOUCOR	1
R	-004	2210013900 390R	* 390R	5% N4 SOUCOR	1
R	-005	2210032200 22K	* 22K	5% N4 SOUCOR	1
R	-006	2210003300 33R	* 33R	5% N4 SOUCOR	1
R	-007	2500210000 10K0 * 1% 0,3 W	* SMA207 10K0 * 1% 0,3 W	SMA207 DRALORIC	1
R	-008	2500133200 3K32 * 1% 0,3 W	* SMA207 3K32 * 1% 0,3 W	SMA207 DRALORIC	1
R	-009	2500178700 7K87 * 1% 0,3 W	* SMA207 7K87 * 1% 0,3 W	SMA207 DRALORIC	1
R	-010	2500269800 69K8 * 1% 0,3 W	* SMA207 69K8 * 1% 0,3 W	SMA207 DRALORIC	1
R	-011	2500211300 11K3 * 1% 0,3 W	* SMA207 11K3 * 1% 0,3 W	SMA207 DRALORIC	1
R	-012	2210018200 820R	* 820R	5% N4 SOUCOR	1
R	-013	2500240200 40K2 * 1% 0,3 W	* SMA207 40K2 * 1% 0,3 W	SMA207 DRALORIC	1
R	-014	2500224900 24K9 * 1% 0,3 W	* SMA207 24K9 * 1% 0,3 W	SMA207 DRALORIC	1
R	-015	2500316200 162K * 1% 0,3 W	* SMA207 162K * 1% 0,3 W	SMA207 DRALORIC	1
R	-016	2200052200 2M2 5% CB	* 2M2 5% CB	ALLEN BRADLEY	1
R	-017	2500310000 100K * 1% 0,3 W	* SMA207 100K * 1% 0,3 W	SMA207 DRALORIC	1
R	-018	2210032200 22K	* 22K	5% N4 SOUCOR	1
R	-019	2210021000 1K0	* 1K0	5% N4 SOUCOR	1
R	-020	2210022200 2K2	* 2K2	5% N4 SOUCOR	1
R	-021	2210013300 330R	* 330R	5% N4 SOUCOR	1
R	-022	2210013300 330R	* 330R	5% N4 SOUCOR	1
R	-023	2210034700 47K	* 47K	5% N4 SOUCOR	1
R	-024	2210034700 47K	* 47K	5% N4 SOUCOR	1
R	-025	2210034700 47K	* 47K	5% N4 SOUCOR	1
R	-026	2210031000 10K	* 10K	5% N4 SOUCOR	1
R	-027	2210012700 270R	* 270R	5% N4 SOUCOR	1
R	-028	2210011800 180R	* 180R	5% N4 SOUCOR	1
R	-029	2210011800 180R	* 180R	5% N4 SOUCOR	1
SN	-001	4160405300 C-MOS 4053	* C-MOS 4053	RTC	1
SN	-002	4200180000 LM 1458 N B+ DIP 8 PATTES	* LM 1458 N B+ DIP 8 PINS NS		1
Z1		1100520000 FIL.NJ.ETAME.4/10	* TINNED BARE THREAD 4/10	ELECTROFIL	0
Z1		1270030400 CI CIRCUIT MODE 2230A	* PC MODE CIRCUIT 2230A	D997003	1
Z1		1300600000 SOUPLISSO 1X1,2 COUL. NATUREL	* SPAGHETTI 1X1,2 GRAY COLORED	HABIA	0
Z4		4900310000 16 SUPPORT C.I. DIL J23-5016	* 16 CONNECTOR P.C. DIL J23-5016	JERMYN	1
Z6		6400280000 PLOT A FOURCHE SOUDE .BFM013C	* SOLDERED FORK CONTACT BFM013C	COMATEL	3
Z8		8006763200 TOUCHE GRISE D6H11 OREOR 2230A	* GREY TOUCH D6H11 OREOR 2230A	A942431	3

 *027010000 04 BLOC ROUES CODEES ... 2230A * 04 SPIN WHEELS BLOCK ... 2230A D920933..... *

REPERE INDEXE	REF. ADRET PART NUMBER	DESCRIPTION	PART DESCRIPTION	FOURNISSEUR/PLAN SUPPLIER/DRAWING	QTE QTY
	0270010000	02 ROUE CODEE EQUIPEE .. 2230A	* 02 FITTED SPIN WHEEL ... 2230A	*942914.....	9
	1100530000	FIL.NU.ETAME.6/10	* TINNED BARE THREAD 6/10	ELECTROFIL	0
	1270100300	CI ROUE CODEUSE	* PC SPIN WHEEL	E997010	1
	1426020000	26 TRANSITION COUDE 3429-5003	* 26 BENDED LINKAGE .. 3429-5003	3M	2
	1540007800	ECROU FENDU M2	* SPLIT THUMB M2	CONTRAVES	8
	1540011600	JOUE BLOC ROUE CODEE 509-1153	* FLANGE BLOCK COD.WHEEL509-1153	CHERRY	4
	1541012000	9PTS SPECIAL TAM.&LEV.20-255 M	* 9PTS SPECIAL TAM.&LEV.20-255 M	CHERRY	1
	4500310000	1 N 4448	* 1 N 4448	ITT	15
	4900150000	16 SUPPORT NATTE 'S'CA-16S-TDS	* 16 MAT CONNECTOR 'S'CA-16S-TDS	EUROPAVIA	1
	6130121200	LAD 2 X12 CYLINDRIQUE FENDUE	* LAD 2 X12 CYLINDRIQUE FENDUE	SAGIC	4
	6200020000	ECROU H M2 U NF E27-411-5 INOX	* NUT H M2 U NF E27-411-5 INOX	BD	4
	6300010000	Z 2,5U(5X0,5) NF E27-611 INOX	* Z 2,5U(5X0,5) NF E27-611 INOX	BD	8
	6301020000	DI 2 EVENTAIL NFE 27-618 INOX	* STEEL 2 FAN NFE 27-618 INOX	BD	8
	6360011000	BAK 2.6X 5X 1 PLATE 100A	* BAK 2.6X 5X 1 PLATE 100A	MFOH	4
	6800220000	TIGE FILETEE M2 LAITON	* THREADED PIN M2 BRASS	WEBER	0
	6900160000	COLLE D'ARRET ROUGE . 9036 BIS	* RED STOP GLUE 9036 BIS	MESPOULET	1

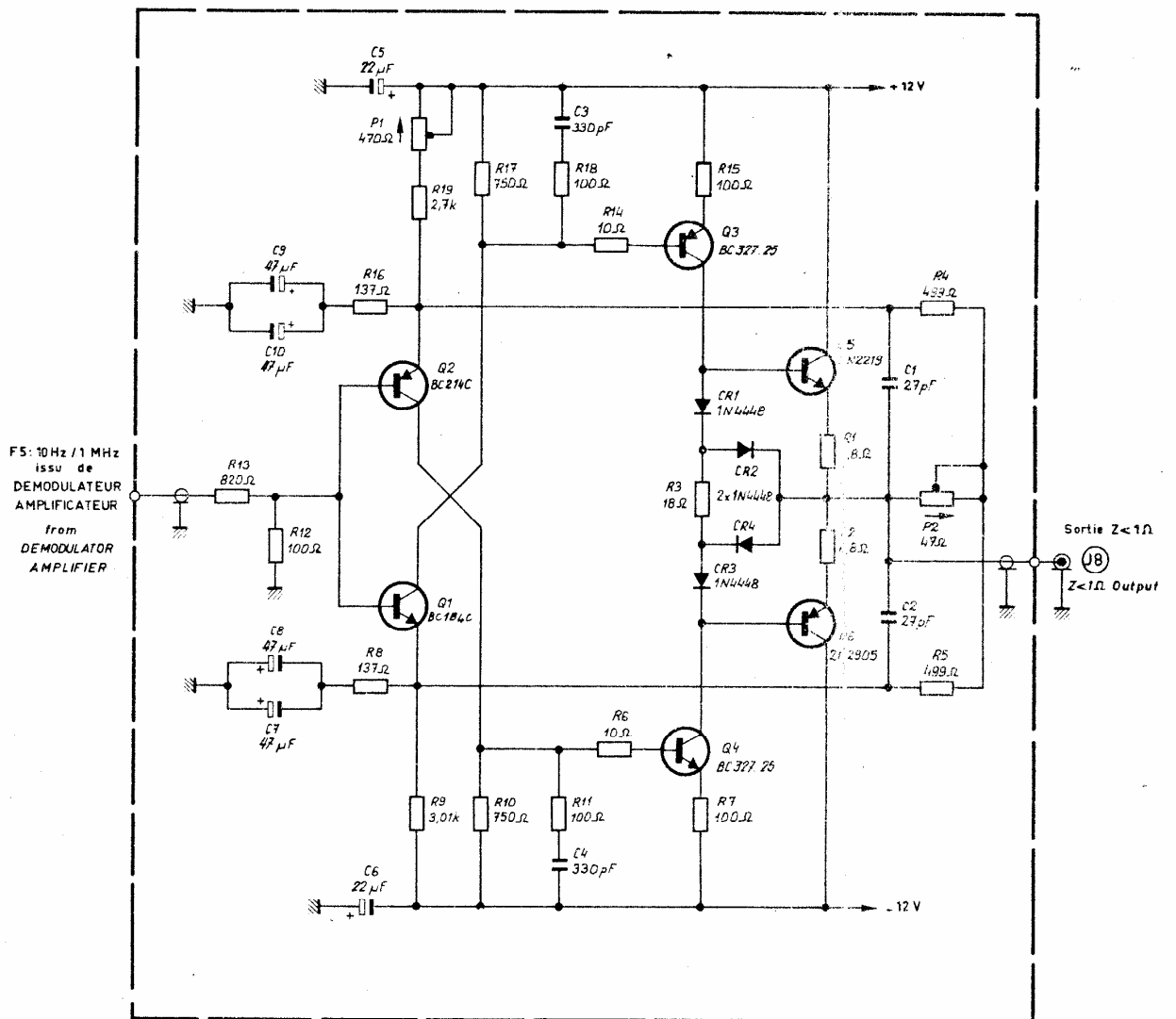

PLATE V-9
PLANCHE V-9

Ce document ne peut être communiqué ni reproduit sans autorisation		act électronique	DATE: JUILLET 1978
ÉTUDE	DESSIN	VERIFIÉ	PAGE: 1 / 1
ACORT	MW	2230 A AMPLIFICATEUR Z<1Ω Z<1Ω AMPLIFIER	977094A

*0270940000 01 AMPLI Z=0 2230A * 01 AMPLI Z=0 2230A E932549.A977094 *

REPERE INDEXE	REF. PART	ADRET NUMBER	DESCRIPTION	PART DESCRIPTION	FOURNISSEUR/PLAN SUPPLIER/DRAWING	QTE QTY
C -001	3120002700	27PF 2,5 'L'	2222 680 10 279	* 27PF 2,5 'L'	2222 680 10 279 COGECO	1
C -002	3120002700	27PF 2,5 'L'	2222 680 10 279	* 27PF 2,5 'L'	2222 680 10 279 COGECO	1
C -003	3120013300	330PF 2,5 'N33'	2222 680 58 331	* 330PF 2,5 'N33'	2222 680 58 331 COGECO	1
C -004	3120013300	330PF 2,5 'N33'	2222 680 58 331	* 330PF 2,5 'N33'	2222 680 58 331 COGECO	1
C -005	3700180000	22MMF/16V 5,08	... STAND L TAG	* 22MMF/16V 5,08	... STAND L TAG STC	1
C -006	3700180000	22MMF/16V 5,08	... STAND L TAG	* 22MMF/16V 5,08	... STAND L TAG STC	1
C -007	3700250000	47MMF/6,3V 5,08	... STAND L TAG	* 47MMF/6,3V 5,08	... STAND L TAG STC	1
C -008	3700250000	47MMF/6,3V 5,08	... STAND L TAG	* 47MMF/6,3V 5,08	... STAND L TAG STC	1
C -009	3700250000	47MMF/6,3V 5,08	... STAND L TAG	* 47MMF/6,3V 5,08	... STAND L TAG STC	1
C -010	3700250000	47MMF/6,3V 5,08	... STAND L TAG	* 47MMF/6,3V 5,08	... STAND L TAG STC	1
D -001	4500310000	1 N 4448	* 1 N 4448 ITT	1
D -002	4500310000	1 N 4448	* 1 N 4448 ITT	1
D -003	4500310000	1 N 4448	* 1 N 4448 ITT	1
D -004	4500310000	1 N 4448	* 1 N 4448 ITT	1
P -001	2131470000	47R 3/4" 15T CERMET	43 P	* 47R 3/4" 15T CERMET	43 P SPECTROL	1
P -002	2130470000	47R 3/4" 15T CERMET	43 P	* 47R 3/4" 15T CERMET	43 P SPECTROL	1
Q -001	4300190000	BC550C /414C/413C/549C	(BC184C)	* BC550C /414C/413C/549C	(BC184C) RTC	1
Q -002	4300110000	BC560C /416C/415C/559C	(BC214C)	* BC560C /416C/415C/559C	(BC214C) RTC	1
Q -003	4300570000	BC 327-25 TO 92 (2N2907)	* BC 327-25 TO 92 (2N2907) ITT	1
Q -004	4300580000	BC 337-25 TO 92 (2N2222)	* BC 337-25 TO 92 (2N2222) ITT	1
Q -005	4800060000	2N2219	* 2N2219 RTC	1
Q -006	4800080000	2N2905	* 2N2905 RTC	1
R -001	2300096800	6R8 SFR 25 1/4W 5% RC2T	* 6R8 SFR 25 1/4W 5% RC2T RTC	1
R -002	2300096800	6R8 SFR 25 1/4W 5% RC2T	* 6R8 SFR 25 1/4W 5% RC2T RTC	1
R -003	2210001800	18R	5% N4	* 18R	5% N4 SOVCOR	1
R -004	2500049900	499R	* 1% 0,3 W SMA207	* 499R	* 1% 0,3 W SMA207 DRALORIC	1
R -005	2500049900	499R	* 1% 0,3 W SMA207	* 499R	* 1% 0,3 W SMA207 DRALORIC	1
R -006	2900001000	10R	5% NK3	* 10R	5% NK3 SOVCOR	1
R -007	2210011000	100R	5% N4	* 100R	5% N4 SOVCOR	1
R -008	2500013700	137R	* 1% 0,3 W SMA207	* 137R	* 1% 0,3 W SMA207 DRALORIC	1
R -009	2500130100	3K01	* 1% 0,3 W SMA207	* 3K01	* 1% 0,3 W SMA207 DRALORIC	1
R -010	2500075000	750R	* 1% 0,3 W SMA207	* 750R	* 1% 0,3 W SMA207 DRALORIC	1
R -011	2210011000	100R	5% N4	* 100R	5% N4 SOVCOR	1
R -012	2210011000	100R	5% N4	* 100R	5% N4 SOVCOR	1
R -013	2210018200	820R	5% N4	* 820R	5% N4 SOVCOR	1
R -014	2900001000	10R	5% NK3	* 10R	5% NK3 SOVCOR	1
R -015	2210011000	100R	5% N4	* 100R	5% N4 SOVCOR	1
R -016	2500013700	137R	* 1% 0,3 W SMA207	* 137R	* 1% 0,3 W SMA207 DRALORIC	1
R -017	2500075000	750R	* 1% 0,3 W SMA207	* 750R	* 1% 0,3 W SMA207 DRALORIC	1
R -018	2210011000	100R	5% N4	* 100R	5% N4 SOVCOR	1
R -019	2210022700	2K7	5% N4	* 2K7	5% N4 SOVCOR	1
Z1	1100010000	FIL NOIR KY30-04	* BLACK THREAD KY30-04 FILECA	0
Z1	1100030000	FIL ROUGE KY30-04	* RED THREAD KY30-04 FILECA	0
Z1	1100070000	FIL BLEU KY30-04	* BLUE THREAD KY30-04 FILECA	0
Z1	1100430000	COAX KX 21 A	* COAX KX 21 A FILECA	0
Z1	1270940000	CI AMPLI Z=0 2230A	* PC AMPLI Z=0 2230A C997094	1
Z4	4900010000	DISSIPATEUR T 05	.. REF 207-AB	* DISSIPATOR T 05	.. REF 207-AB SPETELEC	2
Z4	4900070000	ENTRETOISE T05 T05-001	* SPACER T05 T05-001 JERMYN	2
Z6	6400280000	PLOT A FOURCHE SOUDE	.. BFMQ13C	* SOLDERED FORK CONTACT	.. BFMQ13C COMATEL	2
Z8	8101120000	ECROU A SERTIR M3 H4	NICKELE	* NUT TO SQUEEZE M3 H4	NICKEL 91+71	2

REPERE INDEXE	REF. ADRET PART NUMBER	DESCRIPTION	PART DESCRIPTION	FOURNISSEUR/PLAN SUPPLIER/DRAWING	QTE QTY
	001	0269970000	06 CARTE REGISTRE IEEE . 2230A	* 06 IEEE REGISTER BOARD . 2230A E932563.B976997	1
	001	0274880000	02 CARTE ISOLATION IEEE 2230A	* 02 IEEE INSULATING BOARD 2230A D932961.C977488	1
Z0		0205430000	00 MATTE 26'171'177'L90 2230A	* 00 FLAT-T.26'171 177'L90 2230A ADRET.....	1
Z0		0206700000	00 MATTE 26'171'171'L200 2230	* 00 FLAT-T.26'171 171'L200 2230 ADRET.....	1
Z1		1100530000	FIL.NU.ETAME.6/10	* TINNED BARE THREAD 6/10 ELECTROFIL	0
Z1		1269990000	CARTE INTERCONNEXION 2230A IEC	* INTERCONNECTION BOARD2230A IEC C996999.....SF	1
Z1		1424018400	24PTS CI 'IEEE' REF 57-20240-14	* 24PTS PC 'IEEE' REF 57-20240-14 AMPHENOL	1
Z1		1530214500	DOUBLE INVERSEUR CI TS 2 BLEU	* DOUBLE REVERSEUR PC TS 2 BLUE JEANRENAULT	3
Z6		6100030600	TCB M3X 6 U DIN7985-4,8 INOX	* TCB M3X 6 U DIN7985-4,8 INOX BD	4
Z6		6100031200	TCB M3X12 U DIN7985-4,8 INOX	* TCB M3X12 U DIN7985-4,8 INOX BD	2
Z6		6200010000	ECROU H M2,5 U NFE27-411-5INOX	* NUT H M2.5 U NFE27-411-5 INOX BD	2
Z6		6200030000	ECROU H M3 U NF E27-411-5 INOX	* NUT H M3 U NF E27-411-5 INOX BD	2
Z6		6303010000	ACI 2,5 ONDUFLEX REF 50025132	* STEEL 2.5 ONDUFLEX REF50025132 NOMEL	2
Z6		6303030000	ACI 3 ONDUFLEX REF 52030132	* STEEL 3 ONDUFLEX REF 52030132 NOMEL	8
Z6		6305030000	ACI 3 CONTACT REF 55-03-01	* STEEL 3 CONTACT REF 55-03-01 NOMEL	2
Z6		6701240000	ENLIS 2 L 4	* ENLIS 2 L 4 ACCEL	2
Z8		6700200000	ENMET 2 L 5 M3X0,50 TT	* ENMET 2 L 5 M3X0,50 TT ACCEL	2
Z8		8006702000	PANNEAU OPTION 'I E C' . 2230A	* 'I E C' OPTION PANEL ... 2230A B942235.A942236	1
Z8		8006733100	FIXATION STANDARD IEC . 2230A	* IEC STANDARD ANCHOR 2230A C942347	2

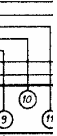
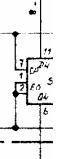
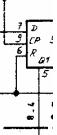
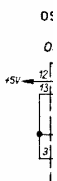
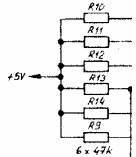
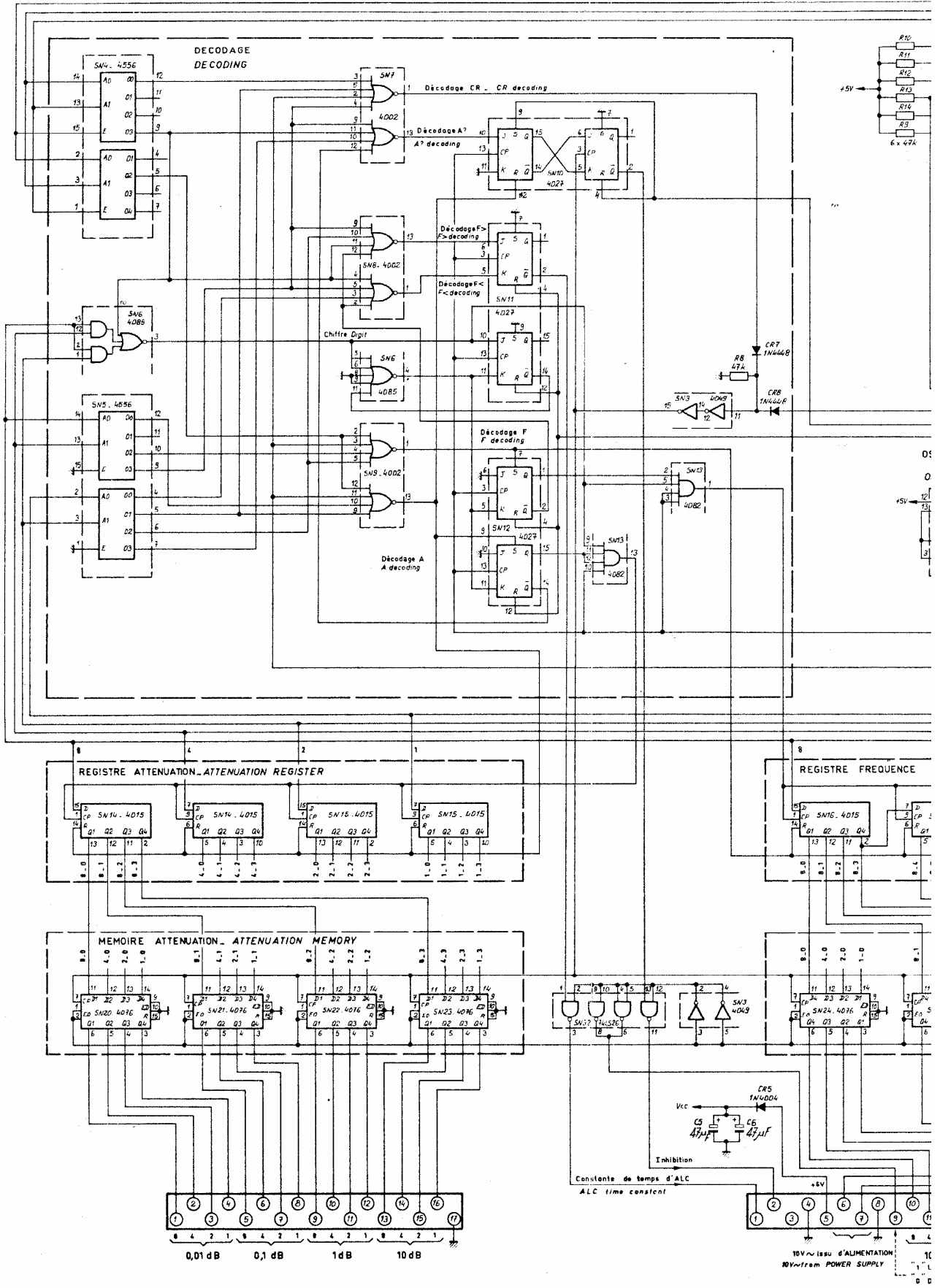

10V issu d'ALIMENTATION
10V from POWER SUPPLY

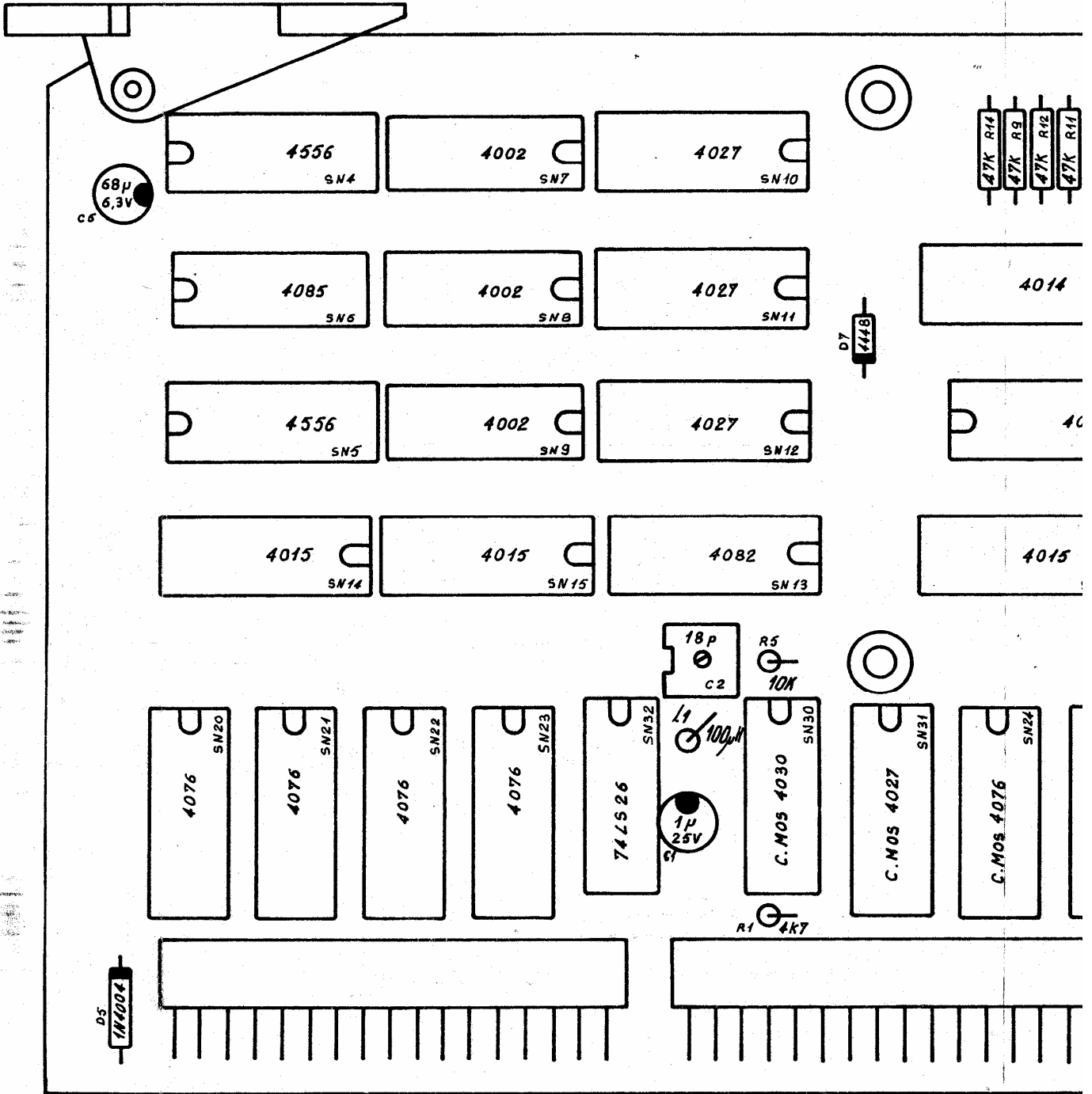

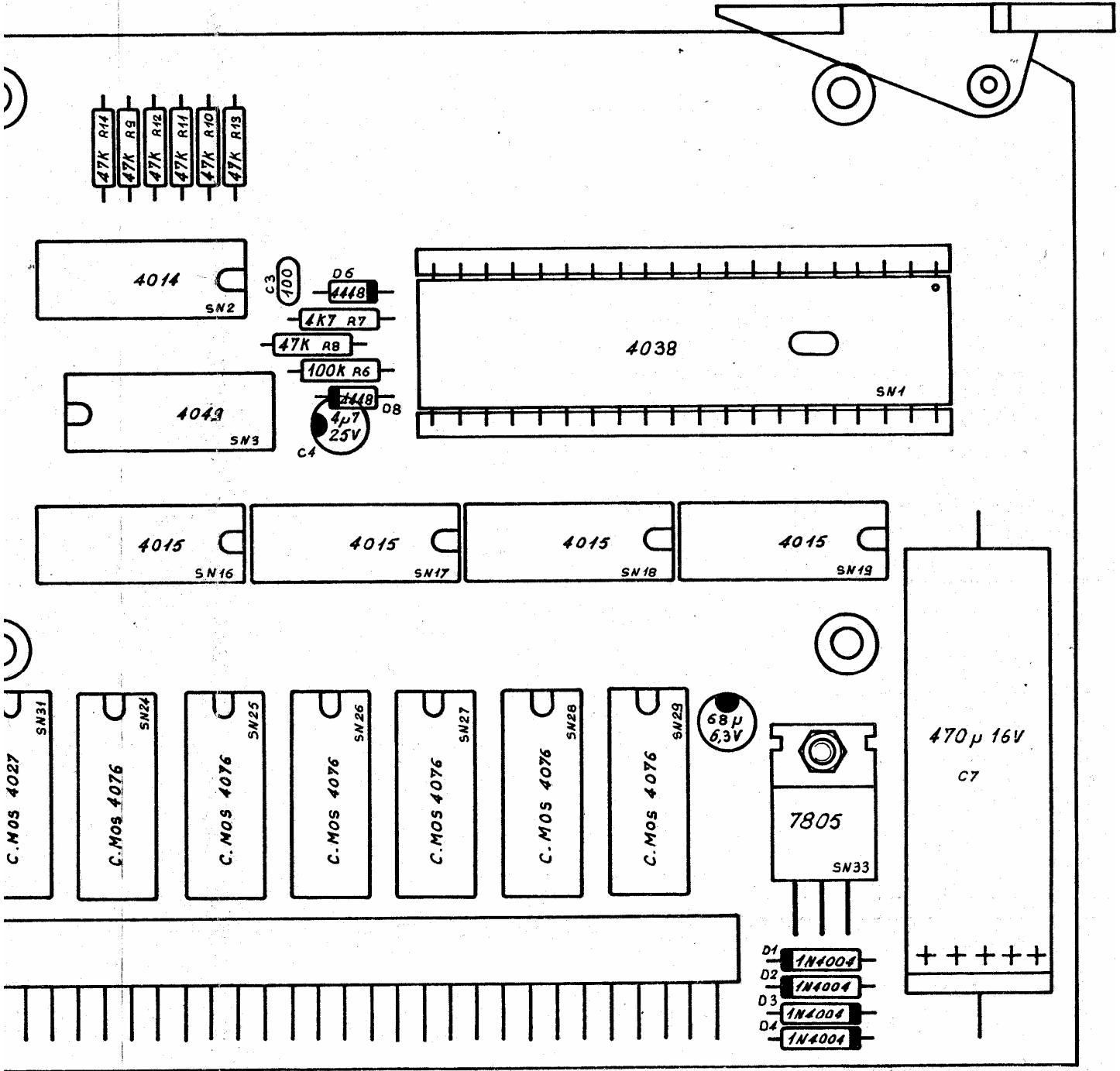

*0269970000 06 CARTE REGISTRE IEEE . 2230A * 06 IEEE REGISTER BOARD . 2230A E932563.8976997 *

REPERE INDEXE	REF. ADRET PART NUMBER	DESCRIPTION	PART DESCRIPTION	FOURNISSEUR/PLAN SUPPLIER/DRAWING	QTE QTY	
B -001	1417016300	TM 17 MCIG	MALE*CARTE*	TM 17 MCIG	MALE TREC	1
B -002	1435004600	TM 35 MCIG	MALE*CARTE*	TM 35 MCIG	TREC	1
C -001	3700020000	1MMF/35V 5,08	STAND L TAG	1MMF/35V 5,08	STAND L TAG	1
C -002	3600120000	4/20 PF ...REF C010 808 23209		4/20 PF ...REF C010 808 23209	RTC(C010)	1
C -003	3120011000	100PF 2,5 N10'2222 680 58 101		100PF 2,5 N10'2222 680 58 101	COGECO	1
C -004	3700100000	4,7MMF/35V 5,08	STAND L TAG	4,7MMF/35V 5,08	STAND L TAG	1
C -005	3700250000	47MMF/6,3V 5,08	STAND L TAG	47MMF/6,3V 5,08	STAND L TAG	1
C -006	3700250000	47MMF/6,3V 5,08	STAND L TAG	47MMF/6,3V 5,08	STAND L TAG	1
C -007	3500280000	470MMF 16V	PROMISIC 031	470MMF 16V	PROMISIC 031	1
C -008	3120004700	47PF 2,5 2222 680 10 479		47PF 2,5 2222 680 10 479	COGECO	1
D -001	4500040000	IN4004		IN4004	ITT	1
D -002	4500040000	IN4004		IN4004	ITT	1
D -003	4500040000	IN4004		IN4004	ITT	1
D -004	4500040000	IN4004		IN4004	ITT	1
D -005	4500040000	IN4004		IN4004	ITT	1
D -006	4500310000	1 N 4448		1 N 4448	ITT	1
D -007	4500310000	1 N 4448		1 N 4448	ITT	1
D -008	4500310000	1 N 4448		1 N 4448	ITT	1
L -001	5300460000	100MMH ORE 53870 DEL 1025-68		100MMH ORE 53870 DEL 1025-68	OREGA DELEVAN	1
R -001	2200024700	4K7	5% N4	4K7	5% N4 SOVCOR	1
R -005	2200031000	10K	5% N4	10K	5% N4 SOVCOR	1
R -006	2210041000	100K	5% N4	100K	5% N4 SOVCOR	1
R -007	2210024700	4K7	5% N4	4K7	5% N4 SOVCOR	1
R -008	2210034700	47K	5% N4	47K	5% N4 SOVCOR	1
R -009	2210034700	47K	5% N4	47K	5% N4 SOVCOR	1
R -010	2210034700	47K	5% N4	47K	5% N4 SOVCOR	1
R -011	2210034700	47K	5% N4	47K	5% N4 SOVCOR	1
R -012	2210034700	47K	5% N4	47K	5% N4 SOVCOR	1
R -013	2210034700	47K	5% N4	47K	5% N4 SOVCOR	1
R -014	2210034700	47K	5% N4	47K	5% N4 SOVCOR	1
SN -001	4160473800	C-MOS 4738		C-MOS 4738	RTC	1
SN -002	4160401400	C-MOS 4014		C-MOS 4014	RTC	1
SN -003	4160404900	C-MOS 4049		C-MOS 4049	RTC	1
SN -004	4160455600	C-MOS 4556		C-MOS 4556	RTC	1
SN -005	4160455600	C-MOS 4556		C-MOS 4556	RTC	1
SN -006	4160408500	C-MOS 4085		C-MOS 4085	RTC	1
SN -007	4160400200	C-MOS 4002		C-MOS 4002	RTC	1
SN -008	4160400200	C-MOS 4002		C-MOS 4002	RTC	1
SN -009	4160400200	C-MOS 4002		C-MOS 4002	RTC	1
SN -010	4160402700	C-MOS 4027		C-MOS 4027	RTC	1
SN -011	4160402700	C-MOS 4027		C-MOS 4027	RTC	1
SN -012	4160402700	C-MOS 4027		C-MOS 4027	RTC	1
SN -013	4160408200	C-MOS 4082		C-MOS 4082	RTC	1
SN -014	4160401500	C-MOS 4015		C-MOS 4015	RTC	1
SN -015	4160401500	C-MOS 4015		C-MOS 4015	RTC	1
SN -016	4160401500	C-MOS 4015		C-MOS 4015	RTC	1
SN -017	4160401500	C-MOS 4015		C-MOS 4015	RTC	1
SN -018	4160401500	C-MOS 4015		C-MOS 4015	RTC	1
SN -019	4160401500	C-MOS 4015		C-MOS 4015	RTC	1
SN -020	4160407600	C-MOS 4076		C-MOS 4076	RTC	1
SN -021	4160407600	C-MOS 4076		C-MOS 4076	RTC	1
SN -022	4160407600	C-MOS 4076		C-MOS 4076	RTC	1
SN -023	4160407600	C-MOS 4076		C-MOS 4076	RTC	1
SN -024	4160407600	C-MOS 4076		C-MOS 4076	RTC	1
SN -025	4160407600	C-MOS 4076		C-MOS 4076	RTC	1
SN -026	4160407600	C-MOS 4076		C-MOS 4076	RTC	1
SN -027	4160407600	C-MOS 4076		C-MOS 4076	RTC	1
SN -028	4160407600	C-MOS 4076		C-MOS 4076	RTC	1
SN -029	4160407600	C-MOS 4076		C-MOS 4076	RTC	1
SN -030	4160407000	C-MOS 4070		C-MOS 4070	RTC	1
SN -031	4160402700	C-MOS 4027		C-MOS 4027	RTC	1
SN -032	4150742600	SN 74 LS 26 N 3		SN 74 LS 26 N 3	TEXAS	1
SN -033	4200260000	7805 UC 1A	REGULATEUR	7805 UC 1A	REGULATOR FAIRCHILD	1
Z0	0206460000	00 ETIQUETTE 6997 . IEC 2230A		00 LABEL 6997	IEC 2230A *942375.....	1
Z1	1269970200	CI CARTE REGISTRE . IEEE 2230A		PC REGISTER BOARD . IEEE 2230A	F996997	1
Z1	1900200000	EXTRACTEUR DE CARTE 'ELEVATEUR'		BOARD EXTRACTOR 'LIFTER'	TRELEC	2
Z4	4900340000	40 SUPPORT C.I. DIL J23.5040		40 CONNECTOR P.C. DIL J23.5040	JERMYN	1
Z6	6100030600	TCB M3X 6 U DIN7985-4,8 INOX		TCB M3X 6 U DIN7985-4,8	INOX BD	1
Z6	6200030000	ECROU H M3 U NF E27-411-5 INOX		NUT H M3 U NF E27-411-5	INOX . BD	1
Z6	6300030000	Z 3U (6X0,8) NF E27-611 INOX		Z 3U (6X0,8) NF E27-611	INOX BD	1
Z6	6400530000	OUILLET LAITON	N° 2070	FIXING EYELET BRASS ..	N° 2070 MFOM	2
Z8	8100120000	00 COLONNETTE A SERTIR 4500		00 PILLAR TO SQUEEZE	4500 ADRET	4

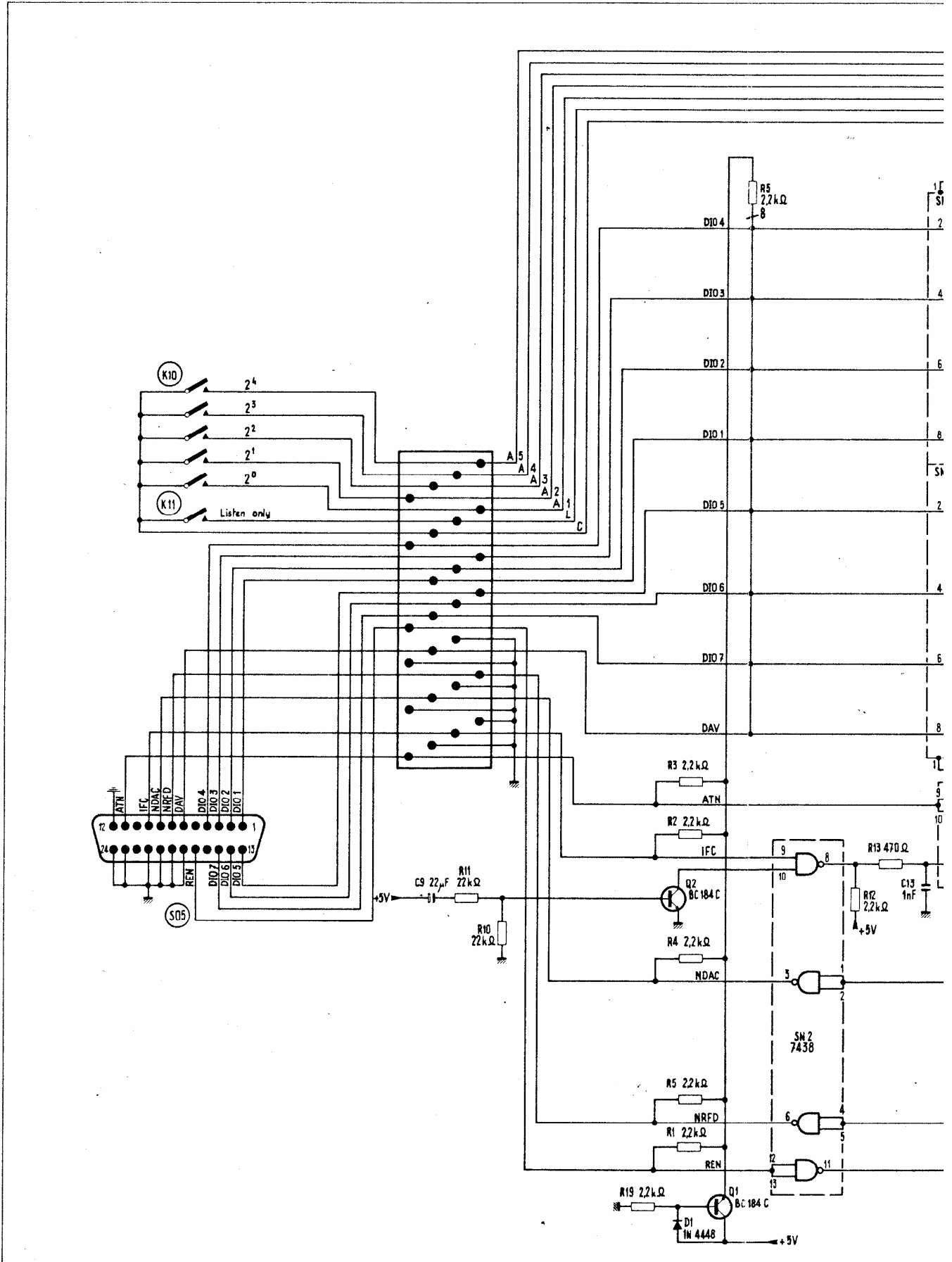

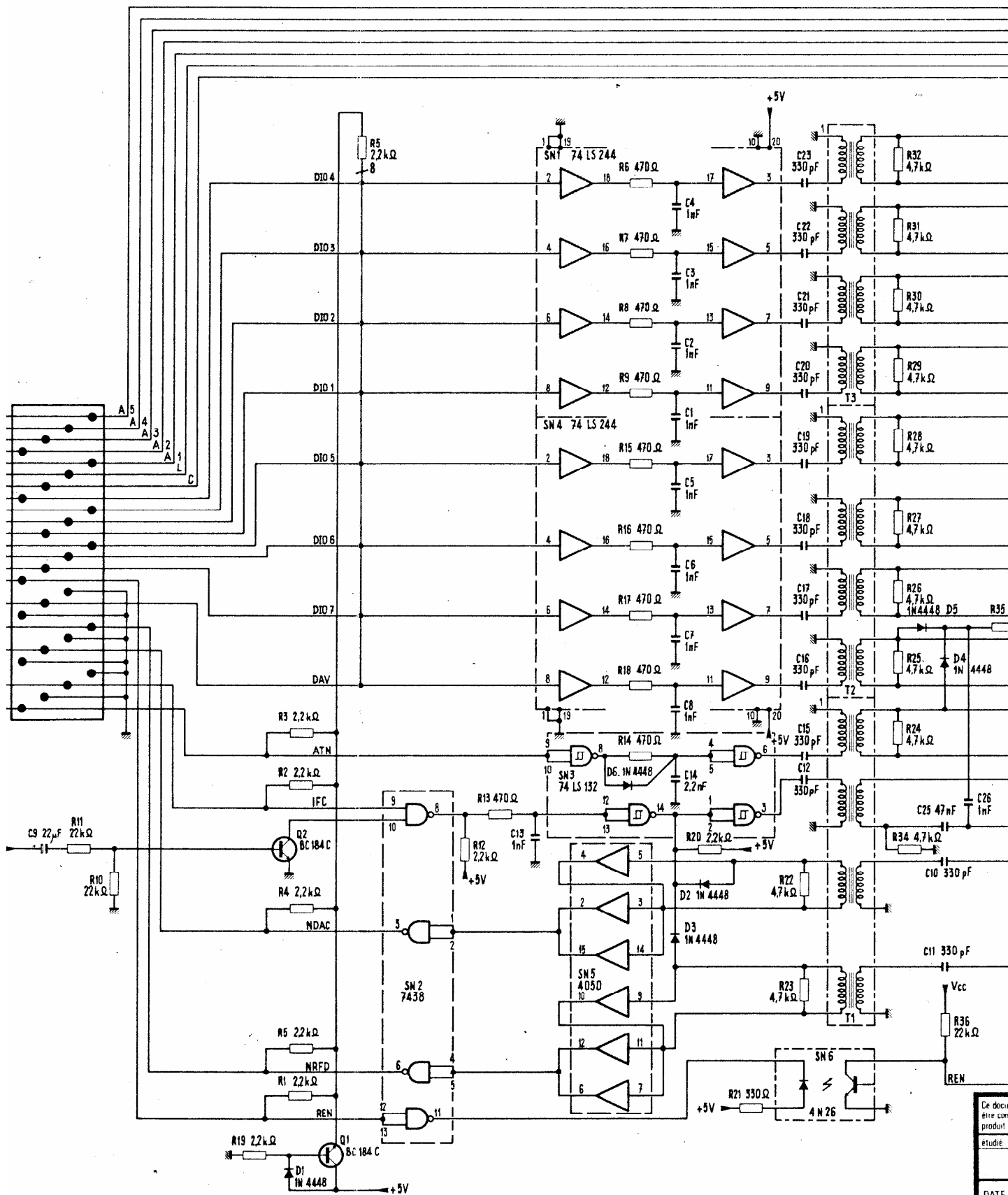

Ce document
 être com
 produit
 étudié
 DATE

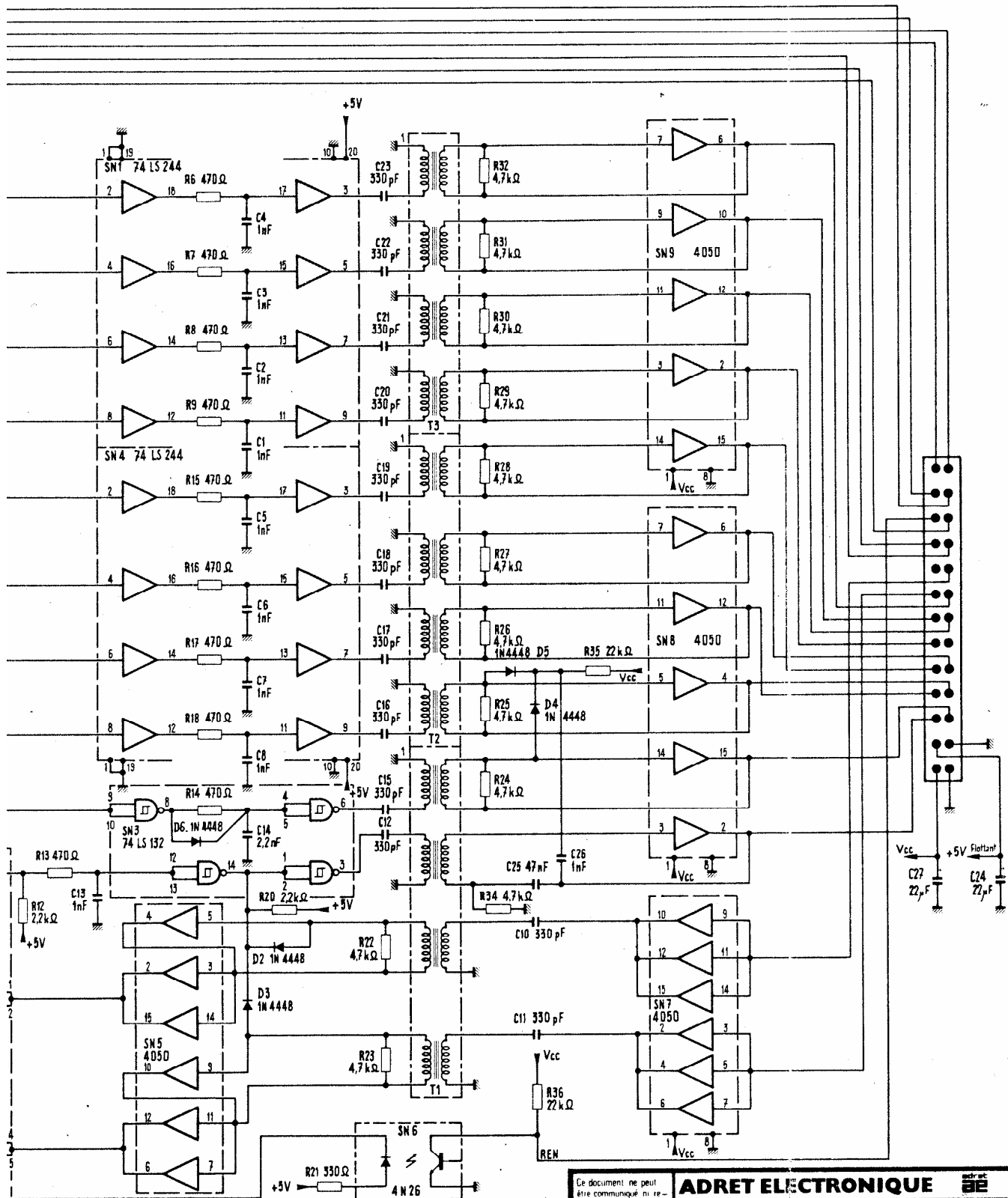

Ce document ne peut être communiqué ni réproduit sans autorisation			ADRET ELECTRONIQUE	
étudié	dessiné	vérifié	ISOLATEUR BUS IEEE	
5				
DATE 09/07/81			ISOLATOR IEEE BUS	
			TYPE Model 2230A	
			PLANCHE V.10	
			Plate V.10	
			C.977488	

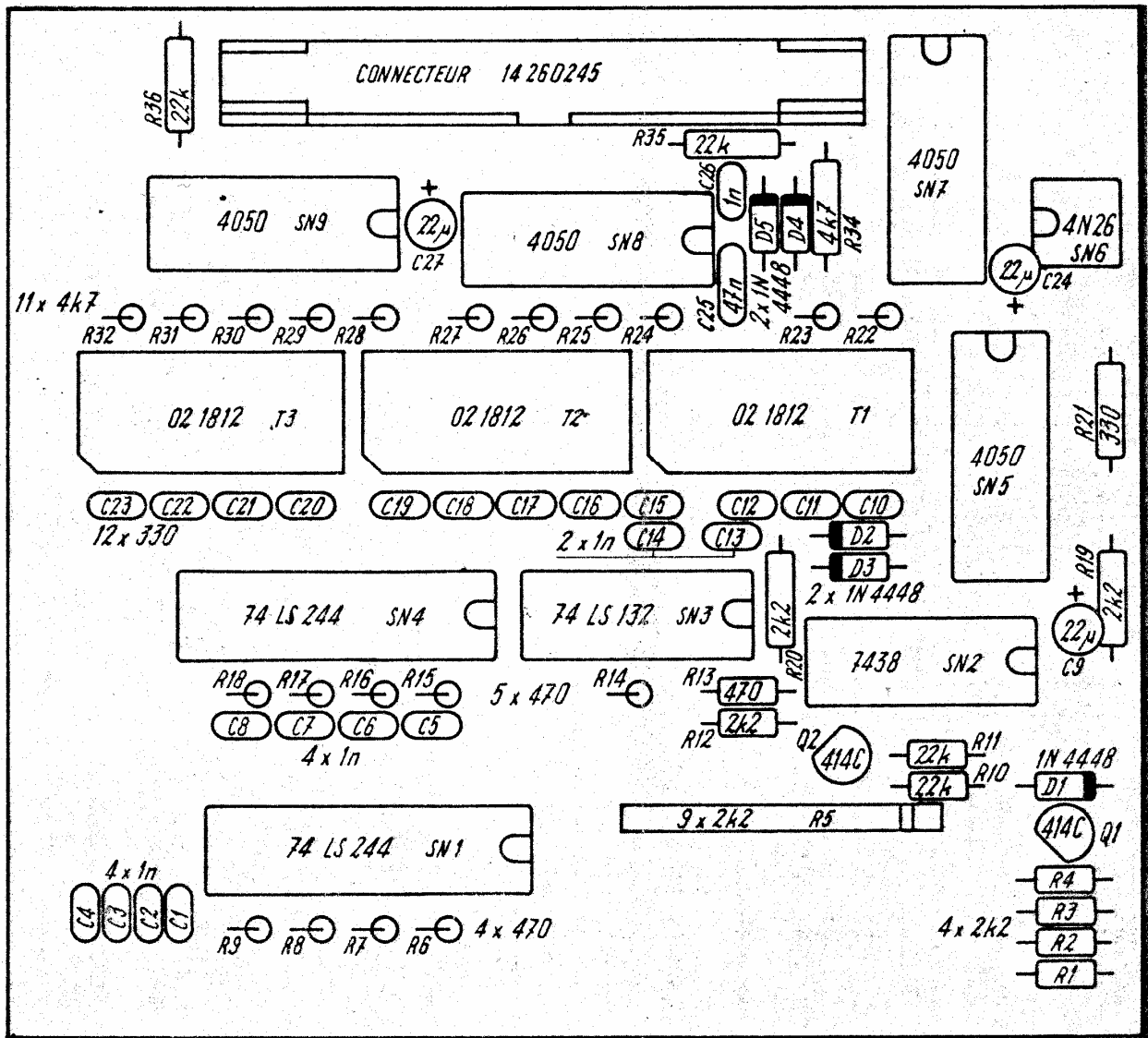

REPERE INDEXE	REF. ADRET PART NUMBER	DESCRIPTION	PART DESCRIPTION	FOURNISSEUR/PLAN SUPPLIER/DRAWING	QTE QTY
B -001	1426024500	26 TRANSITION DROIT 3429-6002	* 26 STRAIGHT LINKAGE 3429-6002	3M	1
C -001	3120021000	1 NF 2,5 2222 630 51 102	* 1 NF 2,5 2222 630 51 102	COGECO	1
C -002	3120021000	1 NF 2,5 2222 630 51 102	* 1 NF 2,5 2222 630 51 102	COGECO	1
C -003	3120021000	1 NF 2,5 2222 630 51 102	* 1 NF 2,5 2222 630 51 102	COGECO	1
C -004	3120021000	1 NF 2,5 2222 630 51 102	* 1 NF 2,5 2222 630 51 102	COGECO	1
C -005	3120021000	1 NF 2,5 2222 630 51 102	* 1 NF 2,5 2222 630 51 102	COGECO	1
C -006	3120021000	1 NF 2,5 2222 630 51 102	* 1 NF 2,5 2222 630 51 102	COGECO	1
C -007	3120021000	1 NF 2,5 2222 630 51 102	* 1 NF 2,5 2222 630 51 102	COGECO	1
C -008	3120021000	1 NF 2,5 2222 630 51 102	* 1 NF 2,5 2222 630 51 102	COGECO	1
C -009	3700180000	22MMF/16V 5,08 ... STAND L TAG	* 22MMF/16V 5,08 ... STAND L TAG	STC	1
C -010	3120013300	330PF 2,5 'N33' 2222 680 58 331	* 330PF 2,5 'N33' 2222 680 58 331	COGECO	1
C -011	3120013300	330PF 2,5 'N33' 2222 680 58 331	* 330PF 2,5 'N33' 2222 680 58 331	COGECO	1
C -012	3120013300	330PF 2,5 'N33' 2222 680 58 331	* 330PF 2,5 'N33' 2222 680 58 331	COGECO	1
C -013	3120021000	1 NF 2,5 2222 630 51 102	* 1 NF 2,5 2222 630 51 102	COGECO	1
C -014	3232220200	2200PF 5,08 10% IRD607	* 2200PF 5,08 10% IRD607	LCC	1
C -015	3120013300	330PF 2,5 'N33' 2222 680 58 331	* 330PF 2,5 'N33' 2222 680 58 331	COGECO	1
C -016	3120013300	330PF 2,5 'N33' 2222 680 58 331	* 330PF 2,5 'N33' 2222 680 58 331	COGECO	1
C -017	3120013300	330PF 2,5 'N33' 2222 680 58 331	* 330PF 2,5 'N33' 2222 680 58 331	COGECO	1
C -018	3120013300	330PF 2,5 'N33' 2222 680 58 331	* 330PF 2,5 'N33' 2222 680 58 331	COGECO	1
C -019	3120013300	330PF 2,5 'N33' 2222 680 58 331	* 330PF 2,5 'N33' 2222 680 58 331	COGECO	1
C -020	3120013300	330PF 2,5 'N33' 2222 680 58 331	* 330PF 2,5 'N33' 2222 680 58 331	COGECO	1
C -021	3120013300	330PF 2,5 'N33' 2222 680 58 331	* 330PF 2,5 'N33' 2222 680 58 331	COGECO	1
C -022	3120013300	330PF 2,5 'N33' 2222 680 58 331	* 330PF 2,5 'N33' 2222 680 58 331	COGECO	1
C -023	3120013300	330PF 2,5 'N33' 2222 680 58 331	* 330PF 2,5 'N33' 2222 680 58 331	COGECO	1
C -024	3700180000	22MMF/16V 5,08 ... STAND L TAG	* 22MMF/16V 5,08 ... STAND L TAG	STC	1
C -025	3233470300	47NF 5,08 10% IRD607	* 47NF 5,08 10% IRD607	LCC	1
C -026	3120021000	1 NF 2,5 2222 630 51 102	* 1 NF 2,5 2222 630 51 102	COGECO	1
C -027	3700180000	22MMF/16V 5,08 ... STAND L TAG	* 22MMF/16V 5,08 ... STAND L TAG	STC	1
D -001	4500310000	1 N 4448	* 1 N 4448	ITT	1
D -002	4500310000	1 N 4448	* 1 N 4448	ITT	1
D -003	4500310000	1 N 4448	* 1 N 4448	ITT	1
D -004	4500310000	1 N 4448	* 1 N 4448	ITT	1
D -005	4500310000	1 N 4448	* 1 N 4448	ITT	1
D -006	4500310000	1 N 4448	* 1 N 4448	ITT	1
Q -001	4300190000	BC550C /414C/413C/549C(BC184C)	* BC550C /414C/413C/549C(BC184C)	RTC	1
Q -002	4300190000	BC550C /414C/413C/549C(BC184C)	* BC550C /414C/413C/549C(BC184C)	RTC	1
R -001	2900022200	2K2 5% NK3	* 2K2 5% NK3	SOUCOR	1
R -002	2900022200	2K2 5% NK3	* 2K2 5% NK3	SOUCOR	1
R -003	2900022200	2K2 5% NK3	* 2K2 5% NK3	SOUCOR	1
R -004	2900022200	2K2 5% NK3	* 2K2 5% NK3	SOUCOR	1
R -005	2610922200	9X2K2 2% 4310R-101-222	* 9X2K2 2% 4310R-101-222	BOURNS	1
R -006	2200014700	470R 5% N4	* 470R 5% N4	SOUCOR	1
R -007	2200014700	470R 5% N4	* 470R 5% N4	SOUCOR	1
R -008	2200014700	470R 5% N4	* 470R 5% N4	SOUCOR	1
R -009	2200014700	470R 5% N4	* 470R 5% N4	SOUCOR	1
R -010	2900032200	22K 5% NK3	* 22K 5% NK3	SOUCOR	1
R -011	2900032200	22K 5% NK3	* 22K 5% NK3	SOUCOR	1
R -012	2900022200	2K2 5% NK3	* 2K2 5% NK3	SOUCOR	1
R -013	2900014700	470R 5% NK3	* 470R 5% NK3	SOUCOR	1
R -014	2200014700	470R 5% N4	* 470R 5% N4	SOUCOR	1
R -015	2200014700	470R 5% N4	* 470R 5% N4	SOUCOR	1
R -016	2200014700	470R 5% N4	* 470R 5% N4	SOUCOR	1
R -017	2200014700	470R 5% N4	* 470R 5% N4	SOUCOR	1
R -018	2200014700	470R 5% N4	* 470R 5% N4	SOUCOR	1
R -019	2210022200	2K2 5% N4	* 2K2 5% N4	SOUCOR	1
R -020	2210022200	2K2 5% N4	* 2K2 5% N4	SOUCOR	1
R -021	2210013300	330R 5% N4	* 330R 5% N4	SOUCOR	1
R -022	2200024700	4K7 5% N4	* 4K7 5% N4	SOUCOR	1
R -023	2200024700	4K7 5% N4	* 4K7 5% N4	SOUCOR	1
R -024	2200024700	4K7 5% N4	* 4K7 5% N4	SOUCOR	1
R -025	2200024700	4K7 5% N4	* 4K7 5% N4	SOUCOR	1
R -026	2200024700	4K7 5% N4	* 4K7 5% N4	SOUCOR	1
R -027	2200024700	4K7 5% N4	* 4K7 5% N4	SOUCOR	1
R -028	2200024700	4K7 5% N4	* 4K7 5% N4	SOUCOR	1
R -029	2200024700	4K7 5% N4	* 4K7 5% N4	SOUCOR	1
R -030	2200024700	4K7 5% N4	* 4K7 5% N4	SOUCOR	1
R -031	2200024700	4K7 5% N4	* 4K7 5% N4	SOUCOR	1
R -032	2200024700	4K7 5% N4	* 4K7 5% N4	SOUCOR	1
R -034	2210024700	4K7 5% N4	* 4K7 5% N4	SOUCOR	1
R -035	2210032200	22K 5% N4	* 22K 5% N4	SOUCOR	1
R -036	2210032200	22K 5% N4	* 22K 5% N4	SOUCOR	1
SN -001	4157424400	SN 74 LS 244 N 3	* SN 74 LS 244 N 3	TEXAS	1
SN -002	4110743800	SN 7438 N	* SN 7438 N	TEXAS	1
SN -003	4157413200	SN 74 LS 132 N 3	* SN 74 LS 132 N 3	TEXAS	1
SN -004	4157424400	SN 74 LS 244 N 3	* SN 74 LS 244 N 3	TEXAS	1
SN -005	4160405000	C-MOS 4050	* C-MOS 4050	RTC	1
SN -006	4000200000	COUPLEUR OPTO 4N26	* OPTO COUPLER 4N26	MOTOROLA	1
SN -007	4160405000	C-MOS 4050	* C-MOS 4050	RTC	1
SN -008	4160405000	C-MOS 4050	* C-MOS 4050	RTC	1

 *0274880000 02 CARTE ISOLATION IEEE 2230A * 02 IEEE INSULATING BOARD 2230A D932961 C977488 *

REPERE INDEXE	REF. ADRET PART NUMBER	DESCRIPTION	PART DESCRIPTION	FOURNISSEUR/PLAN SUPPLIER/DRAWING	QTE QTY
SN -009	4160405000	C-MOS 4050	* C-MOS 4050	RTC	1
T -001	0218120000	01 TRANSFO ISOLATION ... 2230A	* 01 INSULATING TRANSFO .. 2230A	ADRET.....	1
T -002	0218120000	01 TRANSFO ISOLATION ... 2230A	* 01 INSULATING TRANSFO .. 2230A	ADRET.....	1
T -003	0218120000	01 TRANSFO ISOLATION ... 2230A	* 01 INSULATING TRANSFO .. 2230A	ADRET.....	1
Z1	1274880000	CI CARTE ISOLATION 2230A	* INSULATION BOARD PC 2230A	A997488	1

 *0422308302 03 OPTION 1 BCD 2230A * 03 OPTION 1 BCD 2230A A932555(2)..... *

REPERE INDEXE	REF. ADRET PART NUMBER	DESCRIPTION	PART DESCRIPTION	FOURNISSEUR/PLAN SUPPLIER/DRAWING	QTE QTY
	001	0269130000 01CARTE OPTION BCD 2230A	* 01 BCD OPTION BOARD 2230A	932547. 976913	1
Z0	0206730000	00 NATTE 25'171'179'L210 2230	* 00 FLAT-T.25'171 179'L210 2230	ADRET.....	1
Z0	0206740000	00 NATTE 37'180'181'L150 2230	* 00 FLAT-T.37'180 181'L150 2230	ADRET.....	1
Z1	1900120000	VERROUILLAGE FEMELLE . 8630-01	* FEMALE LOCKING 8630-01	SOURIAU	4
Z6	6100030800	TCB M3X 8 U DIN7985-4,8 INOX	* TCB M3X 8 U DIN7985-4,8 INOX	BD	4
Z8	8000090000	ETIQUETTE SIGNALETIQUE . ADRET	* LABEL ADRET	A940006	1
Z8	8006701200	PANNEAU OPTION 'B C D' . 2230A	* 'B C D' OPTION PANEL ... 2230A	B942187.A942185	1

S04

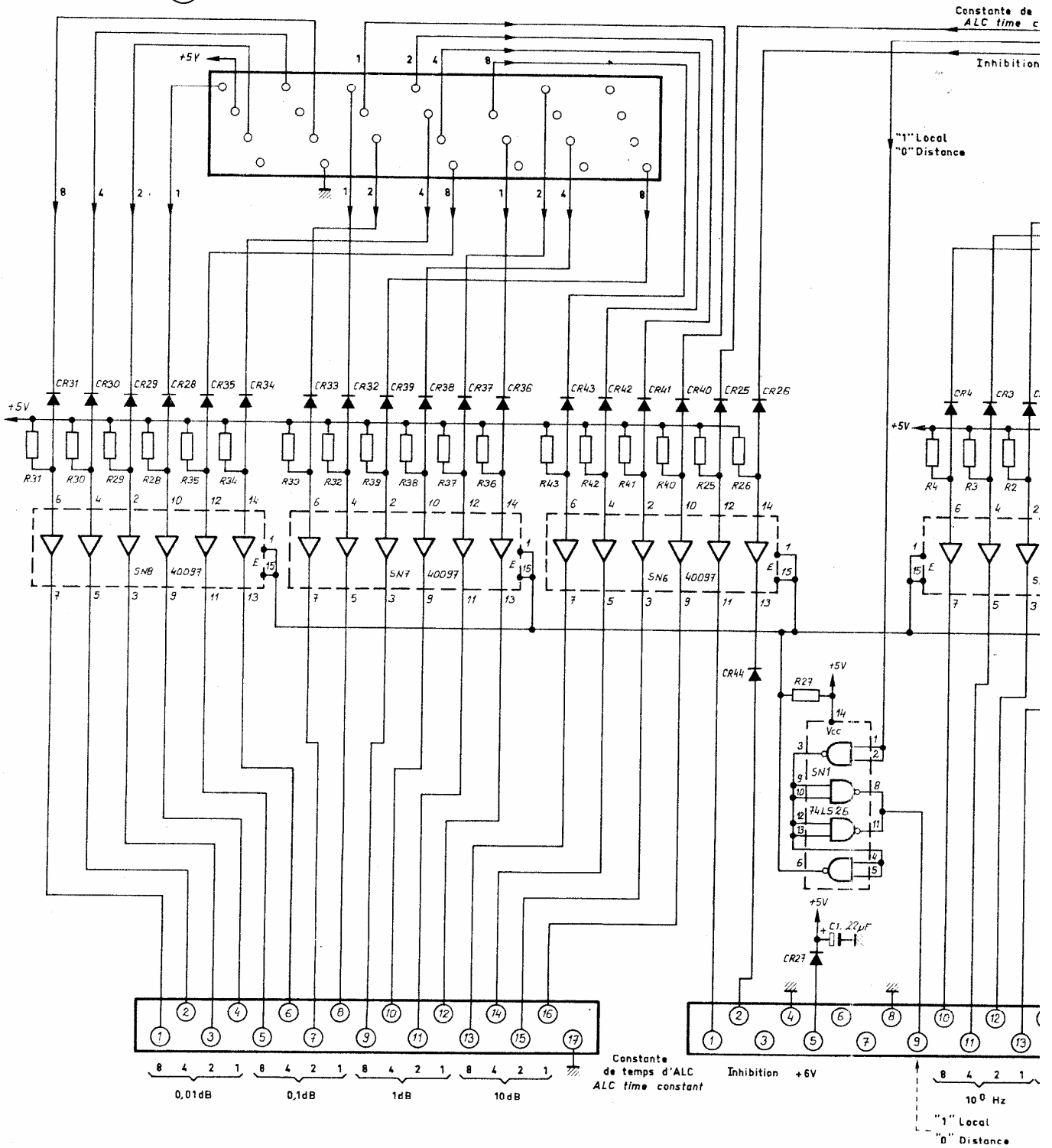

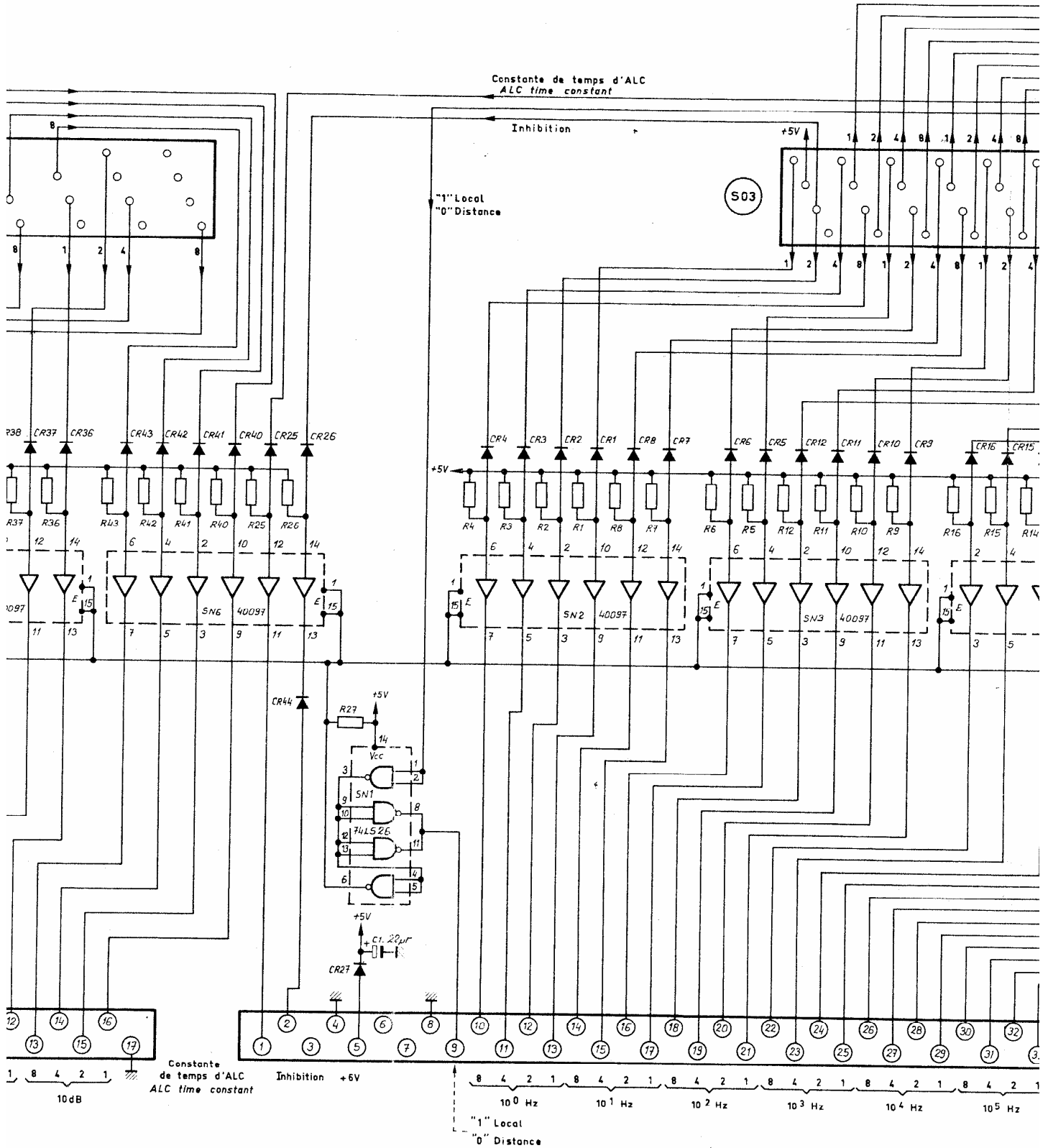

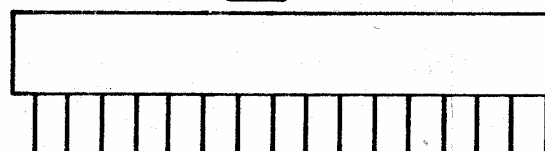
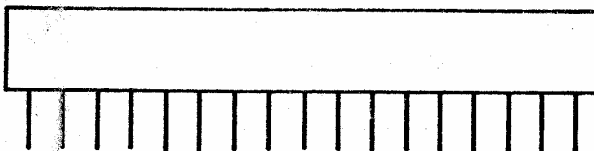
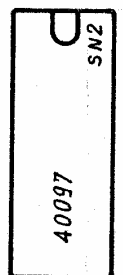
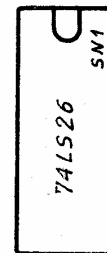
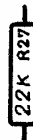
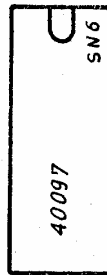
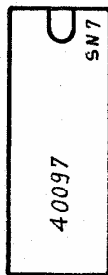
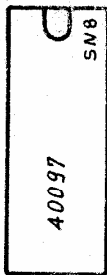
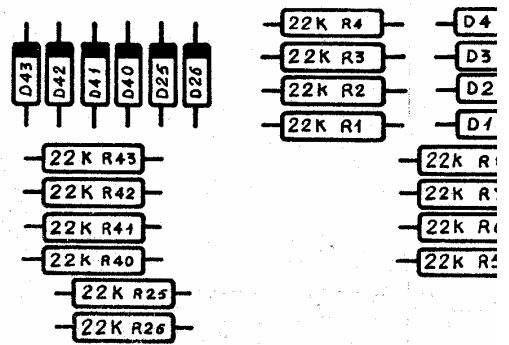
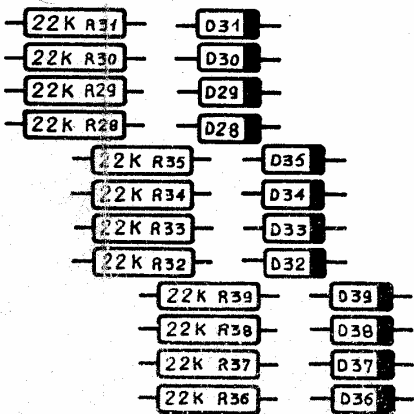
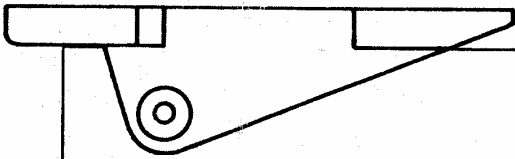

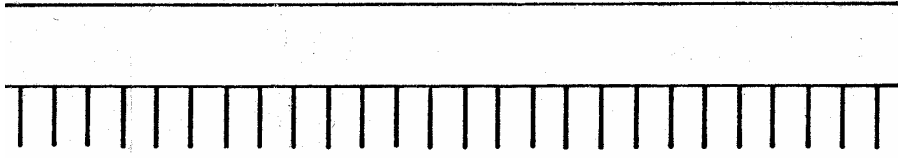
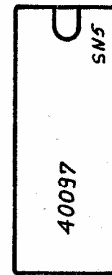
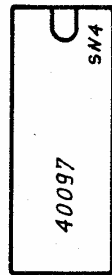
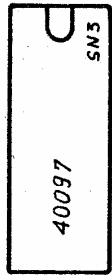
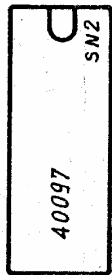
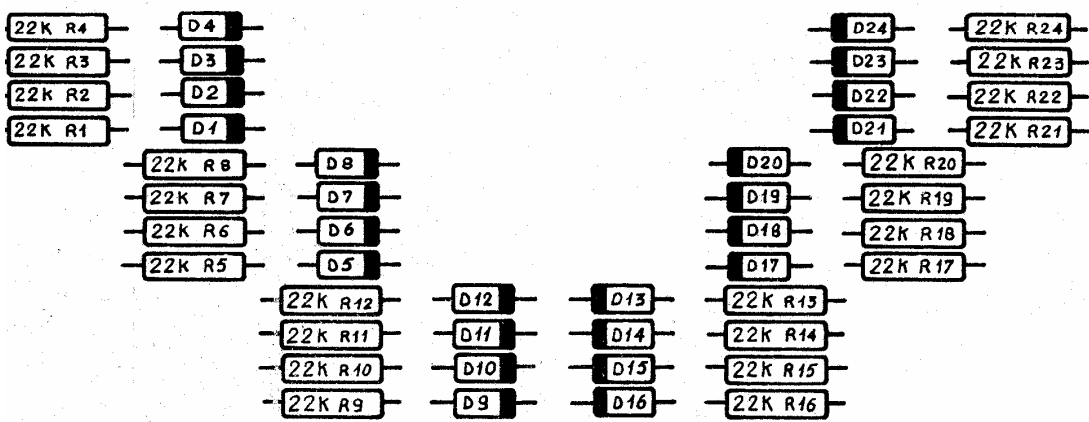

REPERE INDEXE	REF. ADRET PART NUMBER	DESCRIPTION	PART DESCRIPTION	FOURNISSEUR/PLAN SUPPLIER/DRAWING	QTE QTY
B -001	1417016300	TM 17 MCIG MALE*CARTE*	TM 17 MCIG MALE	TRELEC	1
B -002	1435004600	TM 35 MCIG MALE*CARTE*	TM 35 MCIG MALE	TRELEC	1
C -001	3700180000	22MMF/16V 5,08 ... STAND L TAG	22MMF/16V 5,08 ... STAND L TAG	STC	1
D -001	4500310000	1 N 4448	1 N 4448	ITT	1
D -002	4500310000	1 N 4448	1 N 4448	ITT	1
D -003	4500310000	1 N 4448	1 N 4448	ITT	1
D -004	4500310000	1 N 4448	1 N 4448	ITT	1
D -005	4500310000	1 N 4448	1 N 4448	ITT	1
D -006	4500310000	1 N 4448	1 N 4448	ITT	1
D -007	4500310000	1 N 4448	1 N 4448	ITT	1
D -008	4500310000	1 N 4448	1 N 4448	ITT	1
D -009	4500310000	1 N 4448	1 N 4448	ITT	1
D -010	4500310000	1 N 4448	1 N 4448	ITT	1
D -011	4500310000	1 N 4448	1 N 4448	ITT	1
D -012	4500310000	1 N 4448	1 N 4448	ITT	1
D -013	4500310000	1 N 4448	1 N 4448	ITT	1
D -014	4500310000	1 N 4448	1 N 4448	ITT	1
D -015	4500310000	1 N 4448	1 N 4448	ITT	1
D -016	4500310000	1 N 4448	1 N 4448	ITT	1
D -017	4500310000	1 N 4448	1 N 4448	ITT	1
D -018	4500310000	1 N 4448	1 N 4448	ITT	1
D -019	4500310000	1 N 4448	1 N 4448	ITT	1
D -020	4500310000	1 N 4448	1 N 4448	ITT	1
D -021	4500310000	1 N 4448	1 N 4448	ITT	1
D -022	4500310000	1 N 4448	1 N 4448	ITT	1
D -023	4500310000	1 N 4448	1 N 4448	ITT	1
D -024	4500310000	1 N 4448	1 N 4448	ITT	1
D -025	4500310000	1 N 4448	1 N 4448	ITT	1
D -026	4500310000	1 N 4448	1 N 4448	ITT	1
D -027	4500310000	1 N 4448	1 N 4448	ITT	1
D -028	4500310000	1 N 4448	1 N 4448	ITT	1
D -029	4500310000	1 N 4448	1 N 4448	ITT	1
D -030	4500310000	1 N 4448	1 N 4448	ITT	1
D -031	4500310000	1 N 4448	1 N 4448	ITT	1
D -032	4500310000	1 N 4448	1 N 4448	ITT	1
D -033	4500310000	1 N 4448	1 N 4448	ITT	1
D -034	4500310000	1 N 4448	1 N 4448	ITT	1
D -035	4500310000	1 N 4448	1 N 4448	ITT	1
D -036	4500310000	1 N 4448	1 N 4448	ITT	1
D -037	4500310000	1 N 4448	1 N 4448	ITT	1
D -038	4500310000	1 N 4448	1 N 4448	ITT	1
D -039	4500310000	1 N 4448	1 N 4448	ITT	1
D -040	4500310000	1 N 4448	1 N 4448	ITT	1
D -041	4500310000	1 N 4448	1 N 4448	ITT	1
D -042	4500310000	1 N 4448	1 N 4448	ITT	1
D -043	4500310000	1 N 4448	1 N 4448	ITT	1
D -044	4500310000	1 N 4448	1 N 4448	ITT	1
R -001	2210032200	22K 5% N4	22K 5% N4	SOUCOR	1
R -002	2210032200	22K 5% N4	22K 5% N4	SOUCOR	1
R -003	2210032200	22K 5% N4	22K 5% N4	SOUCOR	1
R -004	2210032200	22K 5% N4	22K 5% N4	SOUCOR	1
R -005	2210032200	22K 5% N4	22K 5% N4	SOUCOR	1
R -006	2210032200	22K 5% N4	22K 5% N4	SOUCOR	1
R -007	2210032200	22K 5% N4	22K 5% N4	SOUCOR	1
R -008	2210032200	22K 5% N4	22K 5% N4	SOUCOR	1
R -009	2210032200	22K 5% N4	22K 5% N4	SOUCOR	1
R -010	2210032200	22K 5% N4	22K 5% N4	SOUCOR	1
R -011	2210032200	22K 5% N4	22K 5% N4	SOUCOR	1
R -012	2210032200	22K 5% N4	22K 5% N4	SOUCOR	1
R -013	2210032200	22K 5% N4	22K 5% N4	SOUCOR	1
R -014	2210032200	22K 5% N4	22K 5% N4	SOUCOR	1
R -015	2210032200	22K 5% N4	22K 5% N4	SOUCOR	1
R -016	2210032200	22K 5% N4	22K 5% N4	SOUCOR	1
R -017	2210032200	22K 5% N4	22K 5% N4	SOUCOR	1
R -018	2210032200	22K 5% N4	22K 5% N4	SOUCOR	1
R -019	2210032200	22K 5% N4	22K 5% N4	SOUCOR	1
R -020	2210032200	22K 5% N4	22K 5% N4	SOUCOR	1
R -021	2210032200	22K 5% N4	22K 5% N4	SOUCOR	1
R -022	2210032200	22K 5% N4	22K 5% N4	SOUCOR	1
R -023	2210032200	22K 5% N4	22K 5% N4	SOUCOR	1
R -024	2210032200	22K 5% N4	22K 5% N4	SOUCOR	1
R -025	2210032200	22K 5% N4	22K 5% N4	SOUCOR	1
R -026	2210032200	22K 5% N4	22K 5% N4	SOUCOR	1
R -027	2210032200	22K 5% N4	22K 5% N4	SOUCOR	1
R -028	2210032200	22K 5% N4	22K 5% N4	SOUCOR	1
R -029	2210032200	22K 5% N4	22K 5% N4	SOUCOR	1
R -030	2210032200	22K 5% N4	22K 5% N4	SOUCOR	1
R -031	2210032200	22K 5% N4	22K 5% N4	SOUCOR	1
R -032	2210032200	22K 5% N4	22K 5% N4	SOUCOR	1

 *0269130000 01CARTE OPTION BCD 2230A * 01 BCD OPTION BOARD 2230A 932547. 976913 *

REPERE INDEXE	REF. ADRET PART NUMBER	DESCRIPTION	PART DESCRIPTION	FOURNISSEUR/PLAN SUPPLIER/DRAWING	QTE QTY
R -033	2210032200	22K	5% N4 * 22K	5% N4 SOUCOR	1
R -034	2210032200	22K	5% N4 * 22K	5% N4 SOUCOR	1
R -035	2210032200	22K	5% N4 * 22K	5% N4 SOUCOR	1
R -036	2210032200	22K	5% N4 * 22K	5% N4 SOUCOR	1
R -037	2210032200	22K	5% N4 * 22K	5% N4 SOUCOR	1
R -038	2210032200	22K	5% N4 * 22K	5% N4 SOUCOR	1
R -039	2210032200	22K	5% N4 * 22K	5% N4 SOUCOR	1
R -040	2210032200	22K	5% N4 * 22K	5% N4 SOUCOR	1
R -041	2210032200	22K	5% N4 * 22K	5% N4 SOUCOR	1
R -042	2210032200	22K	5% N4 * 22K	5% N4 SOUCOR	1
R -043	2210032200	22K	5% N4 * 22K	5% N4 SOUCOR	1
SN -001	4150742600	SN 74 LS 26 N 3	* SN 74 LS 26 N 3	TEXAS	1
SN -002	4164009700	C-MOS 40097	* C-MOS 40097	RTC	1
SN -003	4164009700	C-MOS 40097	* C-MOS 40097	RTC	1
SN -004	4164009700	C-MOS 40097	* C-MOS 40097	RTC	1
SN -005	4164009700	C-MOS 40097	* C-MOS 40097	RTC	1
SN -006	4164009700	C-MOS 40097	* C-MOS 40097	RTC	1
SN -007	4164009700	C-MOS 40097	* C-MOS 40097	RTC	1
SN -008	4164009700	C-MOS 40097	* C-MOS 40097	RTC	1
Z0	0206510000	00 ETIQUETTE 2230A	* 00 LABEL 2230A	A&942375.....	1
Z1	1269130300	CI OPTION BCD 2230A	* PC OPTION BCD 2230A	E996913	1
Z1	1900200000	EXTRACTEUR DE CARTE'ELEVATEUR'	* BOARD EXTRACTOR 'LIFTER'	TRELEC	2
Z6	6400530000	OEILLET LAITON N° 2070	* FIXING EYELET BRASS .. N° 2070	MFORM	2

ADRETELECTRONIQUE®

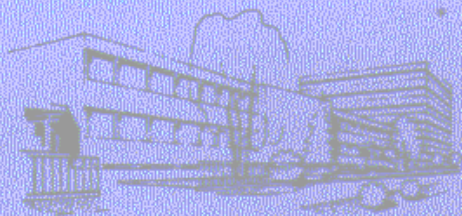

LISTE des COMPOSANTS

—————
COMPONENTS LIST

ADRETELECTRONIQUE®

12, avenue Vladimir Komarov • BP 33 78192 Trappes Cedex 4, France • Tél. 01 1 29 72
7622x 051 00 74 • Télx ADREL497821 F • Swift 6 7905077 - 08014 • C.C.P. Paris 21 797 04 •

FOURNISSEUR/PLAN
SUPPLIER/DRAWING
N O R M E

DESCRIPTION
PART DESCRIPTION

DESCRIPTION

QTE U
QTY M

REF ADRET
PART NUMBER

REF ADRET PART NUMBER	QTE U QTY M	DESCRIPTION	PART DESCRIPTION	FOURNISSEUR/PLAN SUPPLIER/DRAWING
0122309001	1.00	KIT ASSEMBLAGE RACK 3U 1X2230A	KIT ASSEMBLAGE RACK 3U 1X2230A	A910165
0122309002	1.00	KIT ASSEMBLAGE RACK 3U 2X2230A	KIT ASSEMBLAGE RACK 3U 2X2230A	A910165
0122309003	1.00	00 PROLONGATEUR 27 1 GEN 2230A	00 PROLONGATEUR 27 1 GEN 2230A	*932610
0122309004	1.00	00 PROLONGATEUR 27 2 GEN 2230A	00 PROLONGATEUR 27 2 GEN 2230A	*932611
0122309005	1.00	00 PROLONG. OPT. IEEF+BCD 2230A	00 PROLONG. OPT. IEEF+BCD 2230A	A93
0122309006	1.00	00 PROLONG. CDE NIVEAU 2230A	00 PROLONG. CDE NIVEAU 2230A	A93
0122309007	1.00	00 PROLONGATEUR AMPLI 2230A	00 PROLONGATEUR AMPLI 2230A	A93
0205430000	1.00	00 MATTE 26'171'177 L90 2230A	00 FLAT-1-26 171 177 L90 2230A	ADRET
0206460000	1.00	00 ETIQUETTE 6997 IEC 2230A	00 LABEL 6997 IEC 2230A	*942375
0206500000	1.00	00 MATTE 16'137'137 L190	00 FLAT-TOP 16'137'137 L190	ADRET
0206510000	1.00	00 ETIQUETTE	00 LABEL	A&942375
0206520000	1.00	00 8X88 409 D10P4D11d014 2230	00 8X88 409 D10P4D11d014 2230	ADRET 8/SACHET
0206700000	1.00	00 MATTE 26'171'171 L200 2230	00 FLAT-1-26 171 171 L200 2230	ADRET
0206730000	1.00	00 MATTE 25'171'179 L210 2230	00 FLAT-1-25 171 179 L210 2230	ADRET
0206740000	1.00	00 MATTE 37'180'181 L150 2230	00 FLAT-1-37 180 181 L150 2230	ADRET
0206750000	1.00	00 ETIQUETTE 6906	00 LABEL 6906	942375
0206760000	1.00	00 ETIQUETTE 6907	00 LABEL 6907	942375
0206770000	1.00	00 ETIQUETTE 6908	00 LABEL 6908	942375
0206780000	1.00	00 ETIQUETTE 6905	00 LABEL 6905	942375
0208790000	1.00	01 COAX 112' L500	01 COAX 112' L500	ADRET
0209630000	1.00	02 COAX 112' L200	02 COAX 112' L200	ADRET
0210890000	2.00	02 F40 4+4 SPIRES	02 F40 4+4 TURNS	Z94 F40
0211280000	1.00	02 F108 22 SPIRES	02 F108 22 TURNS	Z94 F108
0216280000	1.00	01 F2 63 SPIRES	01 F2 63 TURNS	Z94 F2
0216600000	1.00	00 F40 4X4+4 SPIRES	00 F40 4X4+4 TURNS	Z94 F40
0216650000	1.00	00 F108 18X6 SPIRES	00 F108 18X6 TURNS	Z94 F108
0217170000	2.00	00 F2 95 SPIRES	00 F2 95 TURNS	Z94 F2
0217280000	1.00	01 TORE FT5 T6	01 TORE FT5 T6	ADRET
0217390000	1.00	00 F108 13+13	00 F108 13+13 TURNS	Z94 F108
0218000000	2.00	01 F108 13X1	01 F108 13X1 TURNS	Z94 F108
0218010000	1.00	01 F108 35X6 SPIRES	01 F108 35X6 TURNS	Z94 F108
0218020000	1.00	00 F108 35X4	00 F108 35X4 TURNS	Z94 F108
0218030000	1.00	00 F2 30X38+38	00 F2 30X38+38 TURNS	Z94 F2
0218040000	1.00	00 F2 16X2 SPIRES	00 F2 16X2 TURNS	Z94 F2
0218050000	1.00	00 F2 2X4+4	00 F2 2X4+4 TURNS	Z94 F2
0218060000	1.00	00 F2 46X46 SPIRES	00 F2 46X46 TURNS	Z94 F2
0218120000	3.00	01 TRANSFO ISOLATION	01 INSULATING TRANSFO	ADRET
0218250000	1.00	00 F2 38X6 SPIRES	00 F2 38X6 TURNS	Z94 F2
0219710000	1.00	00 F108	00 F108	Z94 F108
0254002400	8.16	00 POULIE F10 EQUIPEE *EMBASE	00 FITTED PULLEY F10 *SOCKET	ADRET
0254002700	8.16	00 POULIE F 2 EQUIPEE *EMBASE	00 FITTED PULLEY F 2 *SOCKET	ADRET
0254002900	3.06	00 POULIE F40 EQUIPEE *EMBASE	00 FITTED PULLEY F40 *SOCKET	ADRET
0269050000	1.00	14 1ER GENERATION	14 FIRST GENERATION	M932502.A976905
0269060000	1.00	17 2EME GENERATION	17 SECOND GENERATION	M932344.E976906
0269070000	1.00	13 CARTE AMPLIFICATEUR	13 AMPLIFIER BOARD	G932353.A976907
0269080000	1.00	06 CARTE COMMANDE NIVEAU	06 LEVEL CONTROL BOARD	G932349.A976908
0269090000	1.00	03 COMMUTEUR TTL	03 TTL SWITCH	D932366
0269100000	1.00	11 BAQUET DE SORTIE	11 OUTPUT MODULE	J920871.C976910
0269110000	1.00	03 ATTENUATEUR	03 ATTENUATOR	C932524
0269120000	1.00	11 AMPLI SYMETRIQUE	11 SYMMETRICAL AMPLI	H932351.1&2/2..
0269130000	1.00	01 CARTE OPTION BCD	01 BCD OPTION BOARD	932547.976913
0269150100	1.00	07 PORTEUR EQUIPE	07 FITTED MOTHER BD	B920953.A976915

LISTE COMPOSANTS * COMPONENTS LIST

REF ADRET PART NUMBER	QTE U M	DESCRIPTION	PART DESCRIPTION	FOURNISSEUR/PLAN SUPPLIER/DRAWING	N O R M E
0269970000	1.00	06 CARTE REGISTRE IEIEE	06 IEIE REGISTER BOARD	E932563.B976997	XX
0270010000	9.00	02 ROUE CODEE EQUIPEE	02 FITTED SPIN WHEEL	*942914	XX
0270030100	1.00	09 COMMUTATEUR MODE	09 MODE SWITCH	J932523.B977003	XX
0270080300	1.00	02 CHASSIS EQUIPE Z0	02 FITTED CHASSIS Z0	J910214	XX
0270090000	1.00	04 TRANSFO DE SORTIE	02 OUTPUT TRANSFO	A920936	XX
0270100000	1.00	04 BLOC ROUES CODEES	04 SPIN WHEELS BLOCK	D920933	XX
0270110000	1.00	08 PLAQUE AVANT MONTEE	08 ASSEM. FRONT PLATE	L920934	XX
0270130000	1.00	03 NATIE 26 171 177 L140	03 FLAT-1.26 171 177 L140	ADRET	XX
0270940000	1.00	01 AMPLI Z=0	01 AMPLI Z=0	E932549.A977094	XX
0271050000	1.00	03 NATIE 26 171 177 L190	03 FLAT-1.26 171 177 L190	ADRET	XX
0274880000	1.00	02 CARTE ISOLATION IEIE	02 IEIE INSULATING BOARD	D932961.C977488	XX
0281087428	1.00	CAPUCHON PERCE A 10.2	BORED CAP TO 10.2	D942176	XX
0422301002	1.00	00 AVANT HABILLAGE Z=0	00 AVANT HABILLAGE Z=0		XX
0422301300	1.00	02 LOT HABILLAGE FANTOME	02 LOT HABILLAGE FANTOME		XX
0422308301	1.00	08 OPTION 2 IEIE	08 OPTION 2 IEIE		XX
0422308302	1.00	03 OPTION 1 BCD	03 OPTION 1 BCD		XX
0422308304	1.00	01 OPTION 20/21MHZ	01 OPTION 20/21MHZ		XX
1000270000	1.00	ALIMENTATION	POWER SUPPLY	F932565	XX
1100010000	1.53	FIL NOIR	BLACK THREAD	A932555(2)	XX
1100020000	0.54	FIL MARRON	BROWN THREAD	E932214	XX
1100030000	1.21	FIL ROUGE	RED THREAD	FILECA	XX
1100040000	0.53	FIL ORANGE	ORANGE THREAD	FILECA	XX
1100050000	0.30	FIL JAUNE	YELLOW THREAD	FILECA	XX
1100060000	0.39	FIL VERT	GREEN THREAD	FILECA	XX
1100070000	0.93	FIL BLEU	BLUE THREAD	FILECA	XX
1100080000	0.38	FIL VIOLET	PURPLE THREAD	FILECA	XX
1100090000	0.51	FIL GRIS	GREY THREAD	FILECA	XX
1100100000	0.20	FIL BLANC	WHITE THREAD	FILECA	XX
1100110000	0.13	FIL ROSE	PINK THREAD	FILECA	XX
1100430000	2.59	COAX KX 21 A	COAX KX 21 A	FILECA	XX
1100440000	0.80	CABLE BLINDE GRIS	GREY ARMORED CABLE	FILECA	XX
1100450000	0.55	CABLE BLINDE GRIS	GREY ARMORED CABLE	FILECA	XX
1100520000	0.17	FIL NU.ETAME 4/10	TINNED BARE THREAD 4/10	ELECTROFIL	XX
1100530000	0.32	FIL NU.ETAME 6/10	TINNED BARE THREAD 6/10	ELECTROFIL	XX
1100540000	0.02	FIL NU.ETAME 8/10	TINNED BARE THREAD 8/10	ELECTROFIL	XX
1100550000	0.50	FIL NU.ETAME 10/10	TINNED BARE THREAD 10/10	ELECTROFIL	XX
1100620000	21.20	FIL CU SOUD.EMAIL GRADI 8/100E	CU THREAD ENEMAL GRADI 8/100E	ELECTROFIL	XX
1100650000	21.15	FIL CU SOUD.EMAIL GRAI 12/100E	CU THREAD ENEMAL GRAI 12/100E	ELECTROFIL	XX
1100670000	6.00	FIL CUIRE SOUD.EMAIL 15/100E	CU THREAD SOLD. ENEMAL 15/100E	ELECTROFIL	XX
1100680000	1.80	FIL CUIRE SOUD.SOIE 15/100ES	CU THREAD SOLD. SILK 15/100ES	ELECTROFIL	XX
1100720000	6.00	FIL CUIRE SOUD.SOIE 20/100ES	CU THREAD SOLD. SILK 20/100ES	ELECTROFIL	XX
1100840000	0.19	CABLE PLAT 16 CONDUCTEURS 3365	FLAT CABLE 16 CONDUCTORS 3365	3M	XX
1100860000	3.00	FIL 15/100E VERT	THREAD 15/100E GREEN	ELECTROFIL	XX
1100870000	3.00	FIL 15/100E INCOLORE	THREAD 15/100E GRAY	ELECTROFIL	XX
1100910000	0.91	CABLE PLAT 26 CONDUCTEURS 3365	FLAT CABLE 26 CONDUCTORS 3365	3M	XX
1100920000	0.19	CABLE PLAT 40 CONDUCTEURS 3365	FLAT CABLE 40 CONDUCTORS 3365	3M	XX
1100930000	0.60	4FILS TEFLON JGE 30 ST/MM 4061	4THREAD TEFLON JGE30 ST/MM4061	SODIMATEL	XX
1100950000	1.00	VERT/JAUNE H07-V-K(1X1.5ET)	GREEN/YELLOW H07-V-K(1X1.5ET)	FILECA	XX
1269050700	1.00	CI 1 GENERATION	PC 1 GENERATION	K996905	TM
1269080500	1.00	CI 2 GENERATION	PC 2 GENERATION	H996906	XX
1269070400	1.00	CI DEMODULATEUR AMPLI	PC ANPLI DEMODULATOR	L996907	TM
1269080600	1.00	CI COMMANDE NIVEAU	PC LEVEL CONTROL	G996908	XX
1269090300	1.00	CI COMMUTATEUR TTL	PC TTL SWITCHER	D996909	XX
1269110200	1.00	CI ATTENUATEUR	PC ATTENUATOR	F996911	SF

ADRET 09.86

LISTE COMPOSANTS * COMPONENTS LIST

REF ADRET PART NUMBER	QTE U M	DESCRIPTION	PART DESCRIPTION	FOURNISSEUR/PLAN SUPPLIERS/DRAWING	N O R M E
1435013500	1.00	TM 35 FCIG	TM 35 FCIG	TRELEC	A
1435030200	2.00	35PTS FEMELLE 8623-35-64-14-335	35PTS FEMALE 8623-35-64-14-335	SOURIAU	A
1437018000	1.00	37CTS FEMELLE MATTE 609-375	37CTS MAT FEMALE 609-375	ANSLEY	A
1440018100	1.00	40CTS TYPE PCB REF 3418-0000	40CTS TYPE PCB REF 3418-0000	3M	A
1520312200	1.00	03 TOUCHES ORE 10 MODE 2230A	03 TOUCHES ORE 10 MODE 2230A	C932471	A
1520412300	1.00	04 TOUCHES ORE 10 BAOSYM 2230A	04 TOUCHES ORE 10 BAOSYM 2230A	D932472	A
1520512400	1.00	05 TOUCHES ORE 10 TTL 2230A	05 TOUCHES ORE 10 TTL 2230A	C932473	A
1530202000	1.00	INVERSEUR REF:0391584-710 NOIR	REVERSER REF:0391584-710 BLACK	METALLO	A
1530208400	1.00	INVERSEUR REF:039-1584-110	REVERSER REF:039-1584-110	METALLO	A
1530214500	3.00	DOUBLE INVERSEUR CI TS 2 BLEU	DOUBLE REVERSER PC TS 2 BLUE	JEANRENAULT	A
1540007800	8.16	ECROU FENDU M2	SPLIT THUMB M2	CONTRAVES	A
1540011600	4.00	TOUE BLOC ROUE CODEE 509-1153	FLANGE BLOCK COD.WHEEL509-1153	CHERRY	A
1541011500	9.00	10 PTS TAMB. & LEV. MAT 20-260 M	10 PTS TAMB. & LEV. MAT 20-260 M	CHERRY	A
1541012000	1.00	9PTS SPECIAL TAM.&LEV. 20-255 M	9PTS SPECIAL TAM.&LEV. 20-255 M	CHERRY	A
1600090000	3.00	RELAIS 2 INV. G2V-234P-NT.120C	RELAYS 2 REV. G2V-234P-NT.120C	OMRON	A
1700020000	1.02	LUCIOLE M. MIJLET AN643 5U/75MA	BRIGHT FIREFLY AN643 5U/75MA	MAZDA	A
1700340000	1.00	FILTRE 220V+NEUTRE 3A P. EUROPE	FILTIER 220V+NEUTRAL 3A P. EUROPE	EUROPAVIA	A
1710003900	1.00	PORTE FUSIBLE D5406	FUSE BLOCK D5406	ARNOULD	A
1710004000	1.00	TETE 6.3X32(17100039) 031-1613	HEAD 6.3X32(17100039) 031-1613	ARNOULD	A
1720004900	1.00	160MA FST6332 034-3409	160MA FST6332 034-3409	ARNOULD	A
1900010000	1.02	GUIDE CARTE ANTI V.FIXAT. PIONS	BOARD GUIDE FIXATION PIONS	TRELEC	A
1900120000	4.00	VERROUILLAGE FEMELLE 8630-01	BOARD LOCKING REF R221	SOURIAU	A
1900180000	10.20	GUIDE CARTE ANTI VIBR. REF R221	BOARD GUIDE REF R221	TRELEC	A
1900200000	22.00	EXTRACTEUR DE CARTE ELEVATEUR 3X32+6X16	BOARD EXTRACTOR 'LIFTER' 3X32+6X16	MCB COUPER 3X26	A
2122500500	1.00	4K7/10K LIN PK16-DCS 3X32+6X16	4K7/10K LIN PK16-DCS 3X32+6X16	SPECTROL	PM63 T19P 93253
2130470000	1.00	47R 3/4" 15T CERMET	47R 3/4" 15T CERMET	SPECTROL	PM63 T19P 93253
2132470000	1.00	4K7 3/4" 15T CERMET	4K7 3/4" 15T CERMET	SPECTROL	
2133100000	1.00	10K 3/4" 15T CERMET	10K 3/4" 15T CERMET	SPECTROL	
2133220000	2.00	22K 3/4" 15T CERMET	22K 3/4" 15T CERMET	SPECTROL	
2152100000	1.00	1 K T05 CERMET	1 K T05 CERMET	SFERNICE	AP8PY NFC 83251
2152470000	2.00	4K7 T05 CERMET	4K7 T05 CERMET	SFERNICE	AP8PY NFC 83251
2153100000	2.00	10K T05 CERMET	10K T05 CERMET	SFERNICE	
2153220000	1.00	22K T05 CERMET	22K T05 CERMET	SFERNICE	
2200014700	9.18	470R	470R	SOVCOR	
2200024700	12.24	4K7	4K7	SOVCOR	
2200031000	2.04	10K	10K	SOVCOR	
2200034700	2.04	47K	47K	SOVCOR	
2200052200	2.04	2M2 5X	2M2 5X	ALLEN BRADLEY	
2210001200	2.04	12R	12R	SOVCOR	RC-2T NFC 83230
2210001800	2.04	18R	18R	SOVCOR	RC-2T NFC 83230
2210002200	2.04	22R	22R	SOVCOR	RC-2T NFC 83230
2210002700	1.02	27R	27R	SOVCOR	RC-2T NFC 83230
2210003300	1.02	33R	33R	SOVCOR	RC-2T NFC 83230
2210004300	1.02	43R	43R	SOVCOR	RC-2T NFC 83230
2210004700	6.12	47R	47R	SOVCOR	RC-2T NFC 83230
2210005100	4.08	51R	51R	SOVCOR	RC-2T NFC 83230
2210005600	3.06	56R	56R	SOVCOR	RC-2T NFC 83230
2210006800	3.06	68R	68R	SOVCOR	RC-2T NFC 83230
2210011000	27.54	100R	100R	SOVCOR	RC-2T NFC 83230
2210011200	4.08	120R	120R	SOVCOR	RC-2T NFC 83230
2210011500	4.08	150R	150R	SOVCOR	RC-2T NFC 83230
2210011800	2.04	180R	180R	SOVCOR	RC-2T NFC 83230
2210012200	6.12	220R	220R	SOVCOR	RC-2T NFC 83230

LISTE COMPOSANTS * COMPONENTS LIST

REF ADRET PART NUMBER	QTE QTY	U M	DESCRIPTION	DESCRIPTION	PART DESCRIPTION	FOURNISSEUR/PLAN SUPPLIER/DRAWING	N O R M E
2210012700	2,04		270R	SFR 25 1/4U 5%	270R	SOVCOR	RC-2T NFC 83230
2210013300	7,14		330R	SFR 25 1/4U 5%	330R	SOVCOR	RC-2T NFC 83230
2210013900	3,06		390R	SFR 25 1/4U 5%	390R	SOVCOR	RC-2T NFC 83230
2210014700	2,04		470R	SFR 25 1/4U 5%	470R	SOVCOR	RC-2T NFC 83230
2210015600	1,02		560R	SFR 25 1/4U 5%	560R	SOVCOR	RC-2T NFC 83230
2210016800	3,06		680R	SFR 25 1/4U 5%	680R	SOVCOR	RC-2T NFC 83230
2210018200	5,10		820R	SFR 25 1/4U 5%	820R	SOVCOR	RC-2T NFC 83230
2210019100	1,02		910R	SFR 25 1/4U 5%	910R	SOVCOR	RC-2T NFC 83230
2210021000	22,44		1K0	SFR 25 1/4U 5%	1K0	SOVCOR	RC-2T NFC 83230
2210021200	4,08		1K2	SFR 25 1/4U 5%	1K2	SOVCOR	RC-2T NFC 83230
2210021500	3,06		1K5	SFR 25 1/4U 5%	1K5	SOVCOR	RC-2T NFC 83230
2210021800	1,02		1K8	SFR 25 1/4U 5%	1K8	SOVCOR	RC-2T NFC 83230
2210022200	15,30		2K2	SFR 25 1/4U 5%	2K2	SOVCOR	RC-2T NFC 83230
2210022700	6,12		2K7	SFR 25 1/4U 5%	2K7	SOVCOR	RC-2T NFC 83230
2210023300	13,26		3K3	SFR 25 1/4U 5%	3K3	SOVCOR	RC-2T NFC 83230
2210023600	1,02		3K6	SFR 25 1/4U 5%	3K6	SOVCOR	RC-2T NFC 83230
2210023900	1,02		3K9	SFR 25 1/4U 5%	3K9	SOVCOR	RC-2T NFC 83230
2210024700	26,52		4K7	SFR 25 1/4U 5%	4K7	SOVCOR	RC-2T NFC 83230
2210025600	3,06		5K6	SFR 25 1/4U 5%	5K6	SOVCOR	RC-2T NFC 83230
2210026800	2,04		6K8	SFR 25 1/4U 5%	6K8	SOVCOR	RC-2T NFC 83230
2210031000	20,40		10K	SFR 25 1/4U 5%	10K	SOVCOR	RC-2T NFC 83230
2210031200	3,06		12K	SFR 25 1/4U 5%	12K	SOVCOR	RC-2T NFC 83230
2210031500	7,14		15K	SFR 25 1/4U 5%	15K	SOVCOR	RC-2T NFC 83230
2210032200	57,12		22K	SFR 25 1/4U 5%	22K	SOVCOR	RC-2T NFC 83230
2210032700	1,02		27K	SFR 25 1/4U 5%	27K	SOVCOR	RC-2T NFC 83230
2210033300	3,06		33K	SFR 25 1/4U 5%	33K	SOVCOR	RC-2T NFC 83230
2210033900	1,02		39K	SFR 25 1/4U 5%	39K	SOVCOR	RC-2T NFC 83230
2210034700	58,14		47K	SFR 25 1/4U 5%	47K	SOVCOR	RC-2T NFC 83230
2210038200	1,02		82K	SFR 25 1/4U 5%	82K	SOVCOR	RC-2T NFC 83230
2210041000	3,06		100K	SFR 25 1/4U 5%	100K	SOVCOR	RC-2T NFC 83230
2210041200	1,02		120K	SFR 25 1/4U 5%	120K	SOVCOR	RC-2T NFC 83230
2210043900	2,04		390K	SFR 25 1/4U 5%	390K	SOVCOR	RC-2T NFC 83230
2210051000	1,02		1M	SFR 25 1/4U 5%	1M	SOVCOR	RC-2T NFC 83230
2300092200	2,04		2R2	SFR 25 1/4U 5%	2R2	DRALORIC	RC-2T NFC 83230
2300094700	3,06		4R7	SFR 25 1/4U 5%	4R7	DRALORIC	RC-2T U RCMHO
2300095600	2,04		5R6	SFR 25 1/4U 5%	5R6	DRALORIC	
2300096800	2,04		6R8	SFR 25 1/4U 5%	6R8	DRALORIC	
2500010000	1,02		100R	SMA207	100R	DRALORIC	
2500013700	2,04		137R	SMA207	137R	DRALORIC	
2500022100	2,04		221R	SMA207	221R	DRALORIC	
2500022600	2,04		226R	SMA207	226R	DRALORIC	
2500024900	2,04		249R	SMA207	249R	DRALORIC	
2500029400	2,04		294R	SMA207	294R	DRALORIC	
2500039200	2,04		392R	SMA207	392R	DRALORIC	
2500046400	2,04		464R	SMA207	464R	DRALORIC	
2500049900	9,18		499R	SMA207	499R	DRALORIC	
2500052300	1,02		523R	SMA207	523R	DRALORIC	
2500075000	2,04		750R	SMA207	750R	DRALORIC	
2500090900	2,04		909R	SMA207	909R	DRALORIC	
2500110000	5,10		1K00	SMA207	1K00	DRALORIC	
2500115000	1,02		1K50	SMA207	1K50	DRALORIC	
2500119600	1,02		1K96	SMA207	1K96	DRALORIC	
2500124300	2,04		2K43	SMA207	2K43	DRALORIC	
2500130100	3,06		3K01	SMA207	3K01	DRALORIC	

RS-63Y NY5

RS-63Y NY5

LISTE COMPOSANTS * COMPONENTS LIST

REF ADRET QTE U M DESCRIPTION Fournisseur/Plan N O R M E

PART DESCRIPTION

CC NY5
RS-63Y NY5

REF ADRET PART NUMBER	QTE U M	DESCRIPTION	Fournisseur/Plan	N O R M E
2500133200	1.02	3K32	SMA207	DRALORIC
2500139200	2.04	3K92	SMA207	DRALORIC
2500142200	1.02	4K22	SMA207	DRALORIC
2500146400	2.04	4K64	SMA207	DRALORIC
2500149900	2.04	4K99	SMA207	DRALORIC
2500151100	1.02	5K11	SMA207	DRALORIC
2500156200	2.04	5K62	SMA207	DRALORIC
2500157600	1.02	5K76	SMA207	DRALORIC
2500168100	3.06	6K81	SMA207	DRALORIC
2500178700	1.02	7K87	SMA207	DRALORIC
2500182500	2.04	8K25	SMA207	DRALORIC
2500210000	5.10	10K0	SMA207	DRALORIC
2500211300	1.02	11K3	SMA207	DRALORIC
2500215000	1.02	15K0	SMA207	DRALORIC
2500218700	1.02	18K7	SMA207	DRALORIC
2500221000	1.02	21K0	SMA207	DRALORIC
2500224900	1.02	24K9	SMA207	DRALORIC
2500231600	1.02	31K6	SMA207	DRALORIC
2500240200	1.02	40K2	SMA207	DRALORIC
2500249900	1.02	49K9	SMA207	DRALORIC
2500269800	1.02	69K8	SMA207	DRALORIC
2500278700	1.02	78K7	SMA207	DRALORIC
2500280600	1.02	80K6	SMA207	DRALORIC
2500286600	1.02	86K6	SMA207	DRALORIC
2500290900	1.02	90K9	SMA207	DRALORIC
2500310000	1.02	100K	SMA207	DRALORIC
2500311000	2.04	110K	SMA207	DRALORIC
2500312400	1.02	124K	SMA207	DRALORIC
2500316200	1.02	162K	SMA207	DRALORIC
2500324900	1.02	249K	SMA207	DRALORIC
2500349900	1.02	499K	SMA207	DRALORIC
2500924900	4.08	24R9	SMA207	DRALORIC
2500948700	1.02	48R7	SMA207	DRALORIC
2500973200	2.04	73R2	SMA207	DRALORIC
2500975000	1.02	75R0	SMA207	DRALORIC
2600118000	1.00	1K18	H10	HOLCO
2600500000	2.00	5K00	H10	HOLCO
2601100000	1.00	10K00	H10	HOLCO
2601104300	1.00	10K43	H10	HOLCO
2601109000	1.00	10K90	H10	HOLCO
2601301000	1.00	30K10	H10	HOLCO
2608765000	2.00	76R5	REF H10	HOLCO
2608916000	2.00	91R6	REF H10	HOLCO
2609106600	1.00	106R6	REF H10	HOLCO
2609144400	2.00	144R4	REF H10	HOLCO
2610922200	1.00	92K2	REF H10	HOLCO
2683712500	1.00	371.25	AVL	GEKA
2693750000	1.00	3K75	AVL	GEKA
2900001000	2.04	10R	5% NK3	SOUCOR
2900011000	1.02	100R	5% NK3	SOUCOR
2900014700	1.02	470R	5% NK3	SOUCOR
2900022200	5.10	2K2	5% NK3	SOUCOR
2900032200	2.04	22K	5% NK3	SOUCOR

ADRET 09.86

LISTE COMPOSANTS * COMPONENTS LIST

REF ADRET PART NUMBER	QTE U M	DESCRIPTION	DESCRIPTION	PART DESCRIPTION	FOURNISSEUR/PLAN SUPPLIER/DRAWING	N O R M E
2905014700	1,02	CONDENS	470R 5,08 CC	470R 5,08 CC	SOUCCOR	RC-8U NFC 83230
3100000000	5,00	CONDENS	1000PF TRAVERSEE 8020D4000400U	CERAMIC CAPACITORS TO ADJUST	ADRET	
3100430000	2,00	10PF 2,5 'F'	2222 680 10 109	8020D4000400U	BDBO 5 STETTNER	
3120001000	3,06	10PF 2,5 'H'	2222 680 10 159	2222 680 10 109	COGECO	TCE 13L
3120001500	1,04	15PF 2,5 'J'	2222 680 10 189	2222 680 10 159	COGECO	TCE 13L
3120002200	2,04	22PF 2,5 'K'	2222 680 10 229	2222 680 10 189	COGECO	TCE 13L
3120002700	2,04	27PF 2,5 'L'	2222 680 10 279	2222 680 10 229	COGECO	TCE 13L
3120003300	2,04	33PF 2,5	2222 680 10 339	2222 680 10 279	COGECO	TCE 13L
3120003900	1,02	39PF 2,5	2222 680 10 399	2222 680 10 339	COGECO	TCE 13L
3120004700	2,04	47PF 2,5	2222 680 10 479	2222 680 10 399	COGECO	TCE 13L
3120005600	1,02	56PF 2,5	2222 680 10 569	2222 680 10 479	COGECO	TCE 13L
3120006800	7,14	68PF 2,5	2222 680 10 689	2222 680 10 569	COGECO	TCE 13L
3120008200	9,18	82PF 2,5	2222 680 10 829	2222 680 10 689	COGECO	TCE 13L
3120010000	3,06	100PF 2,5	2222 680 58 101	2222 680 10 829	COGECO	TCE 13L
3120011200	1,02	120PF 2,5	2222 680 58 121	2222 680 58 101	COGECO	TCE 13L
3120011500	3,06	150PF 2,5	2222 680 58 151	2222 680 58 121	COGECO	TCE 13L
3120011800	1,02	180PF 2,5	2222 680 58 181	2222 680 58 151	COGECO	TCE 13L
3120012200	2,04	220PF 2,5	2222 680 58 221	2222 680 58 181	COGECO	TCE 13L
3120013300	20,40	330PF 2,5	2222 680 58 331	2222 680 58 221	COGECO	TCE 13L
3120021000	25,50	1 NF 2,5 'C'	2222 630 51 102	2222 680 58 331	COGECO	TCE 13L
3120095600	1,02	5,6PF 2,5 'E'	2222 680 09 568	2222 630 51 102	COGECO	TCE 13L
3120098200	4,08	8,2PF 2,5 'E'	2222 680 09 828	2222 680 09 568	COGECO	TCE 13L
3150031000	28,56	10NF 5,08 63U	2222 60X 767 14	2222 680 09 828	COGECO	TCE 13L
3224220000	1,00	0,22MMF 15(10X40U)POLY CKB68	0,22MMF 15(10X40U)POLY CKB68	60X 767 14	LCC	
3224220200	3,00	0,22MMF 10,2 10X 40U	0,22MMF 10,2 10X 40U	0,22MMF 15(10X40U)POLY CKB68	GAM	
3232220000	1,02	2200PF 10(10X400U)222236855222	2200PF 10(10X400U)222236855222	0,22MMF 10,2 10X 40U	EUROFARAD	
3232330000	1,02	2200PF 5,08 10X	2200PF 5,08 10X	CKM501	COGECO	CPM-7
3232470000	1,02	3300PF 10(10X400U)222236855332	3300PF 10(10X400U)222236855332	IRD607	LCC	IAI
3232470000	1,02	4700PF 10(10X400U)222236855472	4700PF 10(10X400U)222236855472	IRD607	COGECO	
3233300000	1,02	10NF 10(10X400U)222236855103	10NF 10(10X400U)222236855103	222236855332	COGECO	
3233330000	1,02	33NF 10(10X250U)222236845333	33NF 10(10X250U)222236845333	222236855103	COGECO	
3233470300	1,02	47NF 10(10X250U)222236845473	47NF 10(10X250U)222236845473	222236845333	COGECO	
3233680000	1,02	68NF 10(10X250U)222236845368	68NF 10(10X250U)222236845368	222236845473	LCC	
3234100000	2,04	0,1MMF 10(10X250U)222236845104	0,1MMF 10(10X250U)222236845104	47NF 5,08 10X	COGECO	
3234100100	3,06	0,1MMF 7,5 20X 100U	0,1MMF 7,5 20X 100U	IRD607	COGECO	
3300249000	1,00	249PF 7,6 2X 250V ... 59SP	249PF 7,6 2X 250V ... 59SP	IRD607	WIMA	
3300470000	1,00	470PF 7,6 5X 300V ... 59 SP	470PF 7,6 5X 300V ... 59 SP	MKS4	GAM	
3301200100	2,00	2000PF 7,62 5X 250V ... 59 SP	2000PF 7,62 5X 250V ... 59 SP	249PF 7,6 2X 250V ... 59SP	GAM	
3500280000	1,00	470MMF 16U PROMISIC 031	470MMF 16U PROMISIC 031	470PF 7,6 5X 300V ... 59 SP	GAM	
3500430000	1,00	680MMF 16U RELSIC 033	680MMF 16U RELSIC 033	2000PF 7,62 5X 250V	STC SAFCO	
3500440000	2,00	3300MMF 40U RELSIC 033	3300MMF 40U RELSIC 033	PROMISIC 031	STC SAFCO	
3600050000	1,00	2/10 PF ... REF C010 808 23109	2/10 PF ... REF C010 808 23109	RELSIC 033	STC SAFCO	
3600070000	1,00	5,5/65PF JAUNE 2222 808 32659	5,5/65PF YELLOW 2222 808 32659	RELSIC 033	STC SAFCO	
3600120000	1,00	4/20 PF ... REF C010 808 23209	4/20 PF ... REF C010 808 23209	REF C010 808 23109	RTC (C010)	
3600150000	1,00	1,4/5 5PF GRISE C010 808-11558	1,4/5 5PF GREY C010 808-11558	REF C010 808 23209	RTC (C010)	
3700020000	4,08	1MMF/35U 5,08 ... STAND L TAG	1MMF/35U 5,08 ... STAND L TAG	C010 808-11558	RTC (C010)	
3700080000	1,00	4,7MMF/10U L9 20X ... CT513	4,7MMF/10U L9 20X ... CT513	STAND L TAG	STC	
3700100000	2,04	4,7MMF/35U 5,08 ... STAND L TAG	4,7MMF/35U 5,08 ... STAND L TAG	STAND L TAG	SPRAGUE	NFC-UTEC 83-112
3700180000	37,00	22MMF/16U 5,08 ... STAND L TAG	22MMF/16U 5,08 ... STAND L TAG	CT513	STC	
3700250000	52,02	47MMF/6,3U 5,08 ... STAND L TAG	47MMF/6,3U 5,08 ... STAND L TAG	STAND L TAG	STC	
4000010000	2,04	LED ROUGE '5' ... REF CQV 20-4	RED LED '5' ... REF CQV 20-4	STAND L TAG	STC	
4000060000	1,00	LED VERTE '5' ... REF CQV 25-6	GREEN LED '5' ... REF CQV 25-6	REF CQV 20-4	SIEMENS	

LISTE COMPOSANTS * COMPONENTS LIST

REF ADRET PART NUMBER	QTE QTY	U M	DESCRIPTION	PART DESCRIPTION	FURNISSEUR/PLAN SUPPLIER/DRAWING	N O R M E
4000070000	3.00		LED JAUNE '5' ... REF COU 23-6	* YELLOW LED '5' ... REF COU 23-6	SIEMENS	C
4000140000	6.12		LED 5 SUPPORT ... REF HLHP-0103	* BASE 5 LED ... REF HLHP-0103	HP	C
4000200000	1.00		COUPLEUR OPTO 4N26	* OPTO COUPLER 4N26	MOTOROLA	C
4101010500	1.00		MC 10105 P	* MC 10105 P	MOTOROLA	D
4110740000	1.00		SN 7400 N	* SN 7400 N	TEXAS	D
4110743800	1.00		SN 7438 N	* SN 7438 N	TEXAS	D
4150740000	2.00		SN 74 LS 00 N 3	* SN 74 LS 00 N 3	TEXAS	D
4150740200	1.00		SN 74 LS 02 N 3	* SN 74 LS 02 N 3	TEXAS	D
4150742000	5.00		SN 74 LS 20 N 3	* SN 74 LS 20 N 3	TEXAS	D
4150742600	2.00		SN 74 LS 26 N 3	* SN 74 LS 26 N 3	TEXAS	D
4150748600	1.00		SN 74 LS 86 N 3	* SN 74 LS 86 N 3	TEXAS	D
4150749000	2.00		SN 74 LS 90 N 3	* SN 74 LS 90 N 3	TEXAS	D
4150749300	1.00		SN 74 LS 93 N 3	* SN 74 LS 93 N 3	TEXAS	D
4157411200	10.00		SN 74 LS 112 N 3	* SN 74 LS 112 N 3	'FU' TEXAS	D
4157413200	1.00		SN 74 LS 132 N 3	* SN 74 LS 132 N 3	TEXAS	D
4157424400	2.00		SN 74 LS 244 N 3	* SN 74 LS 244 N 3	TEXAS	D
4160400200	3.00		C-MOS 4002	* C-MOS 4002	RTC	D
4160401400	1.00		C-MOS 4014	* C-MOS 4014	RTC	D
4160401500	6.00		C-MOS 4015	* C-MOS 4015	RTC	D
4160402300	1.00		C-MOS 4023	* C-MOS 4023	RTC	D
4160402700	7.00		C-MOS 4027	* C-MOS 4027	RTC	D
4160402800	1.00		C-MOS 4028	* C-MOS 4028	RTC	D
4160404900	1.00		C-MOS 4049	* C-MOS 4049	RTC	D
4160405000	4.00		C-MOS 4050	* C-MOS 4050	RTC	D
4160405300	6.00		C-MOS 4053	* C-MOS 4053	RTC	D
4160407000	1.00		C-MOS 4070	* C-MOS 4070	RTC	D
4160407200	2.00		C-MOS 4072	* C-MOS 4072	RTC	D
4160407600	10.00		C-MOS 4076	* C-MOS 4076	RTC	D
4160408100	1.00		C-MOS 4081	* C-MOS 4081	RTC	D
4160408200	1.00		C-MOS 4082	* C-MOS 4082	RTC	D
4160408500	1.00		C-MOS 4085	* C-MOS 4085	RTC	D
4160451800	3.00		C-MOS 4518	* C-MOS 4518	RTC	D
4160452200	2.00		C-MOS 4522	* C-MOS 4522	RTC	D
4160452600	2.00		C-MOS 4526	* C-MOS 4526	RTC	D
4160455600	2.00		C-MOS 4556	* C-MOS 4556	RTC	D
4160456000	2.00		MC 14560 BCP	* MC 14560 BCP	MOTOROLA	D
4160456100	3.00		MC 14561 BCP	* MC 14561 BCP	MOTOROLA	D
4160458500	4.00		C-MOS 4585	* C-MOS 4585	'FU' RTC	D
4160473800	1.00		C-MOS 4738	* C-MOS 4738	RTC	D
4164009700	4.00		C-MOS 40097	* C-MOS 40097	RTC	D
4200090000	7.00		LM 741 CN B+ ... DIP 8 PATTES	* LM 741 CN B+ ... DIP 8 PINS	NS	D
4200110000	2.00		TBA 673 MODULATEUR 4 QUADRANS.	* TBA 673 MODULATEUR 4 FACES	RTC	D
4200180000	2.00		LM 1458 N B+ DIP 8 PATTES	* LM 1458 N B+ DIP 8 PINS	NS	D
4200220000	1.00		7805 UC REGUL. 6V/1A	* 7805 UC REGUL. 6V/1A	FAIRCHILD	D
4200260000	1.00		7805 UC IA ... TO220	* 7805 UC IA ... TO220	FAIRCHILD	D
4200280000	1.00		7812 UC REGUL. 12V/1A	* 7812 UC REGUL. 12V/1A	FAIRCHILD	D
4200290000	1.00		MC 7912 CP REGUL. 12V/1A	* MC 7912 CP REGUL. 12V/1A	MOTOROLA	D
4200320000	2.00		LF 356 N B+ ... TO220	* LF 356 N B+ ... TO220	NS	D
4200330000	1.00		LM 318 N B+	* LM 318 N B+	NS	D
4300040000	8.00		2 N 918	* 2 N 918	SGS	D
4300050000	10.20		2N2369 A	* 2N2369 A	MOTOROLA	D
4300070000	2.00		2N2894	* 2N2894	MOTOROLA	D
4300110000	14.28		BC560C /416C/415C/559C(8C214C)	* BC560C /416C/415C/559C(8C214C)	RTC	D
4300130000	1.00		BFR 99	* BFR 99	MOTOROLA	D

LISTE COMPOSANTS * COMPONENTS LIST

REF ADRET PART NUMBER	QTE QTY	U M	DESCRIPTION	PART DESCRIPTION	FOURNISSEUR/PLAN SUPPLIER/DRAWING	N O R M E
4300150000	1.02		MPS 2369	MPS 2369	MOTOROLA	D
4300190000	20.40		BC550C /414C/413C/549C(BC184C)	BC550C /414C/413C/549C(BC184C)	RTIC	D
4300570000	2.04		BC 327-25 TO 92	BC 327-25 TO 92	ITT	D
4300580000	3.06		BC 337-25 TO 92	BC 337-25 TO 92	ITT	D
4300600000	2.04		MPS 3640	MPS 3640	MOTOROLA	D
4300610000	2.04		BF 506	BF 506	MOTOROLA	D
4300720000	1.00		BFY 90	BFY 90	RTIC	D
4400080000	1.00		2N4416	2N4416	*930849	D
4500020000	20.40		IN4151	IN4151	FU.ITT	D
4500040000	13.26		IN4004	IN4004	ITT	D
4500310000	150.96		1 N 4448	1 N 4448	ITT	D
4500450000	10.18		BB 409 (STANDARD)	BB 409 (STANDARD)	SIEMENS	D
4500452200	9.18		BB 409 ENTRE 9&11 5PF A 11U CE	BB 409 INPUT 9&11 5PF A 11U IC	ADRET C.ENTREE.	D
4500540000	2.00		IN6263 0035 (EX ESM247&246)	IN6263 (SUBSTIT. ESM247&246)	RTIC	D
4600030000	3.06		ZPD5.1	ZPD5.1	ITT	D
4600050000	1.02		ZPD 6.2	ZPD 6.2	ITT	D
4600080000	2.04		ZPD6.8	ZPD6.8	ITT	D
4600170000	2.04		ZPD 10	ZPD 10	ITT	D
4800060000	7.00		2N2219	2N2219	RTIC	D
4800080000	4.00		2N2905	2N2905	RTIC	D
4900010000	2.04		DISSIPATEUR T 05	DISSIPATOR T 05	SPTELEC	D
4900060000	2.04		DISSIPATEUR T05-204	DISSIPATOR T05-204	JERMYN	D
4900070000	11.22		ENTRETOISE T05	SPACER T05	JERMYN	D
4900080000	2.04		ENTRETOISE DE CI	PC SPACER	JERMYN	D
4900130000	3.06		CALE TO 220	MICA QUIN FOR TO 220	GETELEC	D
4900150000	1.02		REF:AY537-490537	REF:AY537-490537	EUROPAVIA	D
4900180000	1.02		16 SUPPORT MATTE S'CA-16S-TDS	16 MAT CONNECTOR S'CA-16S-TDS	EUROPAVIA	D
4900220000	3.06		BRIDE DIP-LOCK CA 16 200 DL	BRIDLE DIP-LOCK CA 16 200 DL	MOTOROLA	D
4900250000	17.34		CANON ISOLANT TO 220 EPAUL 3.5	INSULATING CANNON 220 EP. 3.5	JERMYN	D
4900310000	6.00		ENTRETOISE T018-0190	SPACER T018-0190	JERMYN	D
4900330000	1.00		16 SUPPORT C.I. DIL J23-5016	16 CONNECTOR P.C. DIL J23-5016	JERMYN	D
4900340000	1.00		40 SUPPORT C.I. DIL J23-5040	40 CONNECTOR P.C. DIL J23-5040	JERMYN	D
5100060000	1.00		SUPPORT DE QUARTZ REF S02Z UFA	CRYSTAL SUPPORT REF S02Z UFA	UMD	D
5100090000	1.00		CLIPS POUR QUARTZ SQ	CLIPS FOR CRYSTAL SQ	UMD	D
5100550000	1.00		QUARTZ 5 MHZ REF JT05E QC36	5 MHZ CRYSTAL REF JT05E QC36	HYQ	D
5100620000	1.00		16MHZ (B HC35U) SP.3000-Y-3205	16MHZ (B.HC35U) SP.3000-Y-3205	QE	D
5300460000	1.00		100MMH ORE 53870 DEL 1025-68	100MMH ORE 53870 DEL 1025-68	OREGA DELEVAN	D
5400010000	19.76		EMBASE 7X7X12	SOCKET 7X7X12	SIRPM(NEOSID)	D
5400030000	19.38		CAPOT METAL 7X7X12	METAL COVERING 7X7X12	SIRPM(NEOSID)	D
5400040000	8.32		POULIE F108 U3.9	PULLEY F108 U3.9	SIRPM(NEOSID)	D
5400050000	13.26		CALE ISOLANTE NEOSID POUR CI	NEOSID INSULATING QUIN FOR PC	-940008	D
5400070000	8.32		POULIE F2 U 3.9	PULLEY F2 U 3.9	SIRPM(NEOSID)	D
5400090000	3.12		POULIE F40 U 3.9	PULLEY F40 U 3.9	SIRPM(NEOSID)	D
5400240000	8.16		COUPELLE K06 F108/H07	CUPEL K06 F108/H07	SIRPM(NEOSID)	D
5400270000	8.16		COUPELLE K06 F2/H 7	CUPEL K06 F2/H07	SIRPM(NEOSID)	D
5400290000	3.06		COUPELLE K06-F40 DANS K07 B-CI	CUPEL K06-F40 IN K07 B-CI	FRANCISD	D
5500020000	1.02		BOITIER POUR TORE	COLLET FOR TOROID	SIRPM(NEOSID)	D
5500030000	6.12		EPINGLE LAITON 65/100	BRASS PINCH 65/100	A940011	D
5500110000	12.24		TUBE 830 GT 4.1X2X12.5	TUBE 830 GT 4.1X2X12.5	BOHIN	D
5500170000	3.06		TORE 481 3.7X1.2X3.5	TORE 481 3.7X1.2X3.5	COFELEC	D
5500210000	3.06		16 SUPPORT COMPOSANT CA-16P-02	16 COMPONENT SUPPORT CA-16P-02	RTIC	D
5500220000	3.06		CAPOT POUR 550021	CAP FOR 550021	EUROPAVIA	D
5500280000	3.06		TORE 3E2 6X4X2 REF432202097040	TORE 3E2 6X4X2 REF432202097040	EUROPAVIA	D
5500300000	12.24		3E2 4X2.2X1.1 REF432202097030	3E2 4X2.2X1.1 REF432202097030	RTIC	D
6100030600	25.50		TCB M3X 6 U DIN7985-4,8 INOX	TCB M3X 6 U DIN7985-4,8 INOX	BO	D

(CRUCIFORME)

REF PART NUMBER	QTE QTY	U M	DESCRIPTION	PART DESCRIPTION	FOURNISSEUR/PLAN SUPPLIER/DRAWING	N O R M E
6100030800	30,60		TCB M3X 8 U DIN7985-4,8	TCB M3X 8 U DIN7985-4,8	BD	(CRUCIFORME)
6100031200	8,16		TCB M3X12 U DIN7985-4,8	TCB M3X12 U DIN7985-4,8	BD	(CRUCIFORME)
6100040600	6,12		TCB M4X 6 U DIN7985-4,6	TCB M4X 6 U DIN7985-4,6	DB	(CRUCIFORM)
6101031200	4,08		TF/90 M3X12 U DIN965-4,8	TF/90 M3X12 U DIN965-4,8	BD	(CRUCIFORM)
6101032000	3,06		TF/90 M3X20 U DIN965-4,8	TF/90 M3X20 U DIN965-4,8	BD	(CRUCIFORM)
6101040600	4,08		ACF 4 X 6 FRAISEE F/90 CRUCIF	ACF 4 X 6 FRAISEE F/90 CRUCIF	SAGIC	(CRUCIFORME)
6101041000	16,32		TF M4X10 U DIN965-5,6	TF M4X10 U DIN965-5,6	BD	(FENDU)
6101110400	1,02		TF M2,5X 4 U NFE27-113-5,6	TF M2,5X 4 U NFE27-113-5,6	BD	(CRUCIFORME)
6105041200	4,08		TRL M4X12T NFE27-128(CRUC)INOX	TRL M4X12T NFE27-128(CRUC)INOX	BD	(CRUCIFORME)
6107020600	6,12		TCL 2 2X6,5 POINT DIN7981BINOX	TCL 2 2X6,5 NIBRI DIN7981BINOX	BD	(CRUCIFORME)
6107241900	2,04		N'4X19 ACI A TOLE F/80 CRUCIF	N'4X19 ACI A TOLE F/80 CRUCIF	BD	(CRUCIFORME)
6130110400	16,32		LAD 2,5X 4 CYLINDRIQUE FENDUE	LAD 2,5 X 4 CYLINDRIQUE FENDUE	SAGIC	
6130110500	6,12		LAD 2,5X 5 CYLINDRIQUE FENDUE	LAD 2,5 X 5 CYLINDRIQUE FENDUE	SAGIC	
6130111000	2,04		LAD 2,5X10 CYLINDRIQUE FENDUE	LAD 2,5 X 10 CYLINDER SLOT	SAGIC	
6130121200	1,02		LAD 2 X 6 FRAISEE F/90 FENDUE	LAD 2 X 6 FRAISEE F/90 FENDUE	SAGIC	
6131120600	10,20		LAD 2 X 6 FRAISEE F/90 FENDUE	LAD 2 X 6 FRAISEE F/90 FENDUE	SAGIC	
6200010000	5,10		ECROU H M2,5 U NFE27-411-5 INOX	NUT H M2,5 U NFE27-411-5 INOX	BD	HEXAGONAL USUEL
6200020000	13,26		ECROU H M2 U NF E27-411-5 INOX	NUT H M2 U NF E27-411-5 INOX	BD	HEXAGONAL USU L
6200030000	20,40		ECROU H M3 U NF E27-411-5 INOX	NUT H M3 U NF E27-411-5 INOX	BD	HEXAGONAL USU L
6200040000	22,44		ECROU H M4 U NF E27-411-5 INOX	NUT H M4 U NF E27-411-5 INOX	BD	HEXAGONAL USUEL
6204030100	4,08		ACI 3 CAGE .. REF 48438 M3	STEEL 3 CAGE .. REF 48438 M3	RAPID	
6220010000	2,04		LAI 2,5 HEXAGONAL USUEL 'H'	BRASS 2,5 USUAL HEXAGON 'H'	SAGIC	
6255040000	2,04		NVL 4 HEXAGONALE ..	NVL 4 HEXAGON	SAGIC	
6300010000	8,16		Z 2,5U(5X0,5) NF E27-611 INOX	Z 2,5U(5X0,5) NF E27-611 INOX	BD	(PLATE ETROITE)
6300030000	4,08		Z 3U (6X0,8) NF E27-611 INOX	Z 3U (6X0,8) NF E27-611 INOX	BD	
6300030100	14,28		M 3U (8X0,8) NF E27-611 INOX	INOX M3 X 8X0,8 FLAT	BD	
6300031000	1,02		3,2X 7X 1 PLATE	3,2X 7X 1 FLAT	BD	
6301010000	2,04		DI 2,5 EVENTAIL NFE27-618 INOX	DI 2,5 FAN .. NFE27-618 INOX	BD	
6301020000	17,34		DI 2,5 EVENTAIL NFE 27-618 INOX	DI 2,5 FAN NFE 27-618 INOX	BD	
6303010000	2,04		ACI 2,5 ONDUFLEX REF 50025132	STEEL 2,5 ONDUFLEX REF50025132	NOMEL	
6303030000	12,24		ACI 3 ONDUFLEX REF 52030132	STEEL 3 ONDUFLEX REF 52030132	NOMEL	
6305030000	16,32		ACI 3 CONTACT REF 55-03-01	STEEL 3 CONTACT REF 55-03-01	NOMEL	
6305040000	18,36		ACI 4 CONTACT REF 55-04-01-32	STEEL 4 CONTACT REF55-04-01-32	NOMEL	
6360011000	5,10		BAK 2,6X 5X 1 PLATE	BAK 2,6X 5X 1 PLATE	MFORM	
6400020000	7,14		RIVET D 2,2 L 3,7 2237 .. 2035	RIVET D 2,2 L 3,7 2237 .. 2035	MFORM	
6400030000	3,06		RIVET D 3 L 4,2 3042	RIVET D 3 L 4,2 3042	MFORM	
6400040000	5,10		RIVET D 3 L 5 3050	RIVET D 3 L 5 3050	MFORM	
6400060000	8,16		RIVET D 1,2 L 2,4 XC 39	RIVET D 1,2 L 2,4 XC 39	MFORM	
6400080000	1,02		RIVET D 1,5 L 2,4 XC 42	RIVET D 1,5 L 2,4 XC 42	MFORM	
6400160000	2,04		COSSE A SOUDER .. 519	SOLDERING TERMINAL 3,2 .. 519	MFORM	
6400270000	7,14		PLOT A FOURCHE SERTI BFM13-16	SQUEEZED FORK CONTACT BFM13-16	COMATEL	
6400280000	26,52		PLOT A FOURCHE SOUDE .. BFMQ13C	SOLDERED FORK CONTACT BFMQ13C	COMATEL	
6400350000	7,14		COSSE A SOUDER .. 2003E	SOLDERING TERMINAL .. 2003E	MFORM	
6400510000	5,10		EQUERRE 10X10 .. LARG 10 EP 1	ANGLEBRACKET10X10 WIDTH10 EP 1	A943051	
6400530000	22,44		OUILLET LAITON .. N° 2070	FIXING EYELET BRASS .. N° 2070	MFORM	
6400540000	24,48		RIVET POP 2,4 L 5 ALU AD32-ABS	POP RIVET 2,4 L 5 ALU AD32-ABS	MFORM	
6400670000	2,04		RIVET POP 3,2 L 4 ALU ABS 41	POP RIVET 3,2 L 4 ALU ABS 41	MFORM	
6400680000	2,04		RIVET POP 3,2 L 4 ALU ABS 41	POP RIVET 3,2 L 4 ALU ABS 41	MFORM	
6400710000	0,18		BUS-BARRE PAS 12,7	BUS-BAR STEP 12,7	SEEM	
6400780000	20,40		RIVET D 20 L 4	RIVET D 20 L 4	MFORM	
6500530000	1,02		CAPUCHON GRIS D14 REF 040-3010	GREY CAP D14 REF 040-3010	ELMA	
6500570000	1,02		D21 CADRAN UTERGE D53 042-4020	D21 BLANK FACE D53 042-4020	ELMA	
6500580000	1,00		21 BOUTON BL/GRIS 6 050-4441	21 BL/GREY BUTTON 6 050-4441	ELMA	

LISTE COMPOSANTS * COMPONENTS LIST

REF ADRET PART NUMBER	QTE U QTY M	DESCRIPTION	PART DESCRIPTION	Fournisseur/Plan Supplier/Drawing	N O R M E
8100120000	4,00	00 COLONNETTE A SERTIR 4500	* 00 PILLAR TO SQUEEZE 4500	ADRET	E
8101120000	2,04	ECROU A SERTIR M3 H4 NICKELLE	* NUT TO SQUEEZE M3 H4 NICKEL	91471	E
8106701100	1,00	01 CADRAN FREQUENCE	* 01 FREQUENCY DIAL	ADRET	E
8106703400	1,00	PANNEAU ADAPT RACK 3U 2X2230A	* PANEL ADAPT RACK 3U 2X2230A	A932493	E
8106703500	1,00	PANNEAU ADAPT RACK 3U 1X2230A	* PANEL ADAPT RACK 3U 1X2230A	A932494	E
8106710300	1,00	01 BAQ AMPLI ATTENUATEUR 2230A	* 01 ATTEN. AMPLI MODULE . 2230A	D920776	E
8106711300	2,00	FLASQUE LAT. CHASSIS ... 2230A	* CHASSIS LAT. FLASK 2230A	F920846	E
8106761400	1,00	CADRE HABILLAGE	* LAGGING FRAME	ADRET	E
9100120000	4,00	TRAIT CAD BIC DE LA COLON	* TREATMENT CAD BIC OF PILLAR	942667	F
9101120000	2,04	NICKELAGE 7101120000	* NICKEL-PLATING TREATMENT	B942192	F
9106701100	1,00	SERIGRAPHIE CADRAN FREQ	* FREQUENCY DIAL ARTWORKING	A932324	F
9106703400	1,00	PEINTURE PANNEAU RACK 2X2230A	* RACK PANEL PAINTING 2X2230A	A932324	F
9106703500	1,00	PEINTURE PANNEAU RACK 1X2230A	* RACK PANEL PAINTING 1X2230A	C920776	F
9106710300	1,00	USINAGE MONTAGE TRAIT .. 2230A	* TREATMENT ASSE.MACHINING 2230A	F920846	F
9106711300	2,00	USINAGE MONTAGE TRAIT .. 2230A	* TREATMENT ASSE.MACHINING 2230A	A942324	F
9106761400	1,00	PEINTURE CADRE	* FRAME PAINTING	C920846	F
9106761500	1,00	USINAGE CADRE	* FRAME MACHINING	C932471	F
9615203122	1,00	03 TOUCHES ORE 10 .MODE.	* 03 TOUCHES ORE 10 .MODE. 2230A	D932472	F
9615204123	1,00	04 TOUCHES ORE 10 BAQSYM	* 04 TOUCHES ORE 10 BAQSYM 2230A	C932473	F
9615205124	1,00	05 TOUCHES ORE 10 .TTL.	* 05 TOUCHES ORE 10 .TTL. 2230A		F

ADRET ELECTRONIQUE®



Liste des sous-ensembles

M A I N T E N A N C E

R E C O M M E N D E D sub-assemblies

or PC board

ADRET ELECTRONIQUE®

12, avenue Vladimir Komarov • BP 33 78192 Trappes Cedex • France • Tél. 051 29 72
Télex 051 00 74 • Télex ADREL 697821 F • Suet 679805077 • (XX) 14 • CCP Paris 21 79704 •

REF ADRET PART NUMBER	QTE QTY	DESCRIPTION	PART DESCRIPTION	SUPPLIER/DRAWING	NORME
-----2230A-----					
0122309003	1	00 PROLONGATEUR 27 1 GEN 2230A	* 00 PROLONGATEUR 27 1 GEN 2230A	*932610.....	
0122309004	1	00 PROLONGATEUR 27 2 GEN 2230A	* 00 PROLONGATEUR 27 2 GEN 2230A	*932611.....	
0122309005	1	00 PROLONG. OPT. IEEE+BCD 2230A	* 00 PROLONG. OPT. IEEE+BCD 2230A	A93.....	
0122309006	1	00 PROLONG. CDE NIVEAU 2230A	* 00 PROLONG. CDE NIVEAU 2230A	A93.....	
0122309007	1	00 PROLONGATEUR AMPLI .. 2230A	* 00 PROLONGATEUR AMPLI .. 2230A	A93.....	

REF ADRET QTE	DESCRIPTION	PART DESCRIPTION	SUPPLIER/DRAWING	NORME
PART NUMBER QTY				
-----2230A-----				
0269050000 1	14 1ER GENERATION	2230A * 14 FIRST GENERATION	2230A M932502.A976905	
0269060000 1	17 2EME GENERATION	2230A * 17 SECOND GENERATION ...	2230A M932344.E976906	
0269070000 1	13 CARTE AMPLIFICATEUR .	2230A * 13 AMPLIFIER BOARD	2230A G932353.A976907	
0269080000 1	06 CARTE COMMANDE NIVEAU	2230A * 06 LEVEL CONTROL BOARD .	2230A G932349.A976908	
0269100000 1	11 BAQUET DE SORTIE	2230A * 11 OUTPUT MODULE	2230A J920871.C976910	
0270100000 1	04 BLOC ROUES CODEES ...	2230A * 04 SPIN WHEELS BLOCK ...	2230A D920933.....	
0422308301 1	08 OPTION 2 IEEE	2230A * 08 OPTION 2 IEEE	2230A F932565	
0422308302 1	03 OPTION 1 BCD	2230A * 03 OPTION 1 BCD	2230A A932555(2).....	

REF ADRET PART NUMBER	QTE QTY	DESCRIPTION	PART DESCRIPTION	SUPPLIER/DRAWING	NORME
-----2230A-----					
0269070000	1	13 CARTE AMPLIFICATEUR .	2230A * 13 AMPLIFIER BOARD	2230A G932353.A976907	
0269100000	1	11 BAQUET DE SORTIE	2230A * 11 OUTPUT MODULE	2230A J920871.C976910	

REF ADRET PART NUMBER	QTE QTY	DESCRIPTION	PART DESCRIPTION	SUPPLIER/DRAWING	NORME
-----2230A-----					
0206520000	1	00 8XBB 409 D1&D4&D11&D14 2230	* 00 8XBB 409 D1&D4&D11&D14 2230	ADRET 8/SACHET	
0270010000	1	02 ROUE CODEE EQUIPEE ... 2230A	* 02 FITTED SPIN WHEEL ... 2230A	*942914	
0270030100	1	09 COMMUTATEUR MODE ... 2230A	* 09 MODE SWITCH ... 2230A	J932523.B977003	
0281067428	1	CAPUCHON PERCE A 10.2 .. 2230A	* BORED CAP TO 10.2 .. 2230A	D942176	
1000270000	1	ALIMENTATION ... 2230A	* POWER SUPPLY ... 2230A	E932214	
1520312200	1	03 TOUCHES ORE 10 .MODE. 2230A	* 03 TOUCHES ORE 10 .MODE. 2230A	C932471	
1520412300	1	04 TOUCHES ORE 10 BAQSYM 2230A	* 04 TOUCHES ORE 10 BAQSYM 2230A	D932472	
1520512400	1	05 TOUCHES ORE 10 .TTL. 2230A	* 05 TOUCHES ORE 10 .TTL. 2230A	C932473	
1600900000	1	RELAIS 2 INV. G2V-234P-NT.12DC	* RELAYS 2 REV. G2V-234P-NT.12DC	OMRON	
1700020000	1	LUCIOLE M.MIDJET AN643 5U/75MA	* BRIGHT FIREFLY ..AN643 5U/75MA	MAZDA	
1720004900	1	160MA FST6332 034-3409	* 160MA FST6332 034-3409	ARNOULD	
2122500500	1	4K7/10K LIN PK16-DCS 3X32+6X16	* 4K7/10K LIN PK16-DCS 3X32+6X16	MCB COUPER 3X26	
2130470000	1	47R 3/4" 15T CERMET 43 P	* 47R 3/4" 15T CERMET 43 P	SPECTROL	
2131470000	1	47OR 3/4" 15T CERMET 43 P	* 47OR 3/4" 15T CERMET 43 P	SPECTROL	
2132470000	1	4K7 3/4" 15T CERMET 43 P	* 4K7 3/4" 15T CERMET 43 P	SPECTROL	
2133100000	1	10K 3/4" 15T CERMET 43 P	* 10K 3/4" 15T CERMET 43 P	SPECTROL	PM63 T19P 932
2133220000	1	22K 3/4" 15T CERMET 43 P	* 22K 3/4" 15T CERMET 43 P	SPECTROL	PM63 T19P 932
2152100000	1	1 K T05 CERMET T 7 YA	* 1 K T05 CERMET T 7 YA	SFERNICE	
2152470000	1	4K7 T05 CERMET T 7 YA	* 4K7 T05 CERMET T 7 YA	SFERNICE	
2153100000	1	10K T05 CERMET T 7 YA	* 10K T05 CERMET T 7 YA	SFERNICE	AP8PY NFC 832
2153220000	1	22K T05 CERMET T 7 YA	* 22K T05 CERMET T 7 YA	SFERNICE	AP8PY NFC 832
2610922200	1	9X2K2 2% 4310R-101-222	* 9X2K2 2% 4310R-101-222	BOURNS	
3234100000	1	0,1MMF 10(10x250V)222236845104	* 0,1MMF 10(10x250V)222236845104	COGECO	
3500280000	1	470MMF 16V PROMISIC 031	* 470MMF 16V PROMISIC 031	SIC SAFCO	
3500430000	1	6800MMF 16V RELSIC 033	* 6800MMF 16V RELSIC 033	SIC SAFCO	
3500440000	1	3300MMF 40V RELSIC 033	* 3300MMF 40V RELSIC 033	SIC SAFCO	
3600050000	1	2/10 PF ... REF C010 808 23109	* 2/10 PF ... REF C010 808 23109	RTC (C010)	LNZ 106
3600070000	1	5,5/65PF JAUNE 2222 808 32659	* 5,5/65PF YELLOW 2222 808 32659	RTC(C010)	
3600120000	1	4/20 PF ... REF C010 808 23209	* 4/20 PF ... REF C010 808 23209	RTC(C010)	
3600150000	1	1,4/5,5PF GRISE C010 808-11558	* 1,4/5,5PF GREY C010 808-11558	RTC(C010)	
3700020000	1	1MMF/35V 5,08 ... STAND L TAG	* 1MMF/35V 5,08 ... STAND L TAG	STC	
3700080000	1	4,7MMF/10V L9 20% ... CTS13	* 4,7MMF/10V L9 20% ... CTS13	SPRAGUE	NFC-UTEC 83-1
3700100000	1	4,7MMF/35V 5,08 ... STAND L TAG	* 4,7MMF/35V 5,08 ... STAND L TAG	STC	
3700180000	2	22MMF/16V 5,08 ... STAND L TAG	* 22MMF/16V 5,08 ... STAND L TAG	STC	
3700250000	1	47MMF/6,3V 5,08 ... STAND L TAG	* 47MMF/6,3V 5,08 ... STAND L TAG	STC	
4000010000	1	LED ROUGE '5' ... REF CQV 20-4	* RED LED '5' ... REF CQV 20-4	SIEMENS	
4000060000	1	LED VERTE '5' ... REF CQV 25-6	* GREEN LED '5' ... REF CQV 25-6	SIEMENS	
4000070000	1	LED JAUNE '5' ... REF CQV 23-6	* YELLOW LED '5' ... REF CQV 23-6	SIEMENS	
4000140000	1	LED 5 SUPPORT REF HLHP-0103	* BASE 5 LED ... REF HLHP-0103	HP	
4000200000	1	COUPLEUR OPTO 4N26	* OPTO COUPLER 4N26	MOTOROLA	
4101010500	1	MC 10105 P	* MC 10105 P	MOTOROLA	
4110740000	1	SN 7400 N	* SN 7400 N	TEXAS	
4110743800	1	SN 7438 N	* SN 7438 N	TEXAS	
4150740000	1	SN 74 LS 00 N 3	* SN 74 LS 00 N 3	TEXAS	
4150740200	1	SN 74 LS 02 N 3	* SN 74 LS 02 N 3	TEXAS	
4150742000	1	SN 74 LS 20 N 3	* SN 74 LS 20 N 3	TEXAS	
4150742600	1	SN 74 LS 26 N 3	* SN 74 LS 26 N 3	TEXAS	
4150748600	1	SN 74 LS 86 N 3	* SN 74 LS 86 N 3	TEXAS	
4150749000	1	SN 74 LS 90 N 3	* SN 74 LS 90 N 3	TEXAS	
4150749300	1	SN 74 LS 93 N 3	* SN 74 LS 93 N 3	TEXAS	
4157411200	1	SN 74 LS 112 N	* SN 74 LS 112 N	'FU' TEXAS	
4157413200	1	SN 74 LS 132 N 3	* SN 74 LS 132 N 3	TEXAS	
4157424400	1	SN 74 LS 244 N 3	* SN 74 LS 244 N 3	TEXAS	
4160400200	1	C-MOS 4002	* C-MOS 4002	RTC	
4160401400	1	C-MOS 4014	* C-MOS 4014	RTC	
4160401500	1	C-MOS 4015	* C-MOS 4015	RTC	
4160402300	1	C-MOS 4023	* C-MOS 4023	RTC	
4160402700	1	C-MOS 4027	* C-MOS 4027	RTC	
4160402800	1	C-MOS 4028	* C-MOS 4028	RTC	
4160404900	1	C-MOS 4049	* C-MOS 4049	RTC	
4160405000	1	C-MOS 4050	* C-MOS 4050	RTC	
4160405300	1	C-MOS 4053	* C-MOS 4053	RTC	
4160407000	1	C-MOS 4070	* C-MOS 4070	RTC	
4160407200	1	C-MOS 4072	* C-MOS 4072	RTC	
4160407600	1	C-MOS 4076	* C-MOS 4076	RTC	
4160408100	1	C-MOS 4081	* C-MOS 4081	RTC	
4160408200	1	C-MOS 4082	* C-MOS 4082	RTC	
4160408500	1	C-MOS 4085	* C-MOS 4085	RTC	
4160451800	1	C-MOS 4518	* C-MOS 4518	RTC	
4160452200	1	C-MOS 4522	* C-MOS 4522	RTC	
4160452600	1	C-MOS 4526	* C-MOS 4526	RTC	
4160455600	1	C-MOS 4556	* C-MOS 4556	RTC	
4160456000	1	C-MOS 4560	* C-MOS 4560	MC 14560 BCP	MOTOROLA
4160456100	1	C-MOS 4561	* C-MOS 4561	MC 14561 BCP	MOTOROLA
4160458500	1	C-MOS 4585	* C-MOS 4585	'FU' RTC	
4160473800	1	C-MOS 4738	* C-MOS 4738	RTC	
4164009700	1	C-MOS 40097	* C-MOS 40097	RTC	

REF ADRET QTE	DESCRIPTION	PART DESCRIPTION	SUPPLIER/DRAWING	NORME
PART NUMBER QTY				
4200090000 1	LM 741 CN B+ . DIP 8 PATTES ..	* LM 741 CN B+ . DIP 8 PINS	NS	
4200110000 1	TBA 673 MODULATEUR 4 QUADRANS.	* TBA 673 MODULATOR 4 FACES	RTC	
4200180000 1	LM 1458 N B+ DIP 8 PATTES	* LM 1458 N B+ DIP 8 PINS	NS	
4200220000 1	7806 UC REGUL.6U/1A TO220	* 7806 UC REGUL.6U/1A TO220	FAIRCHILD	
4200260000 1	7805 UC 1A REGULATEUR	* 7805 UC 1A REGULATOR	FAIRCHILD	
4200280000 1	7812 UC REGUL.12U/1A TO 220	* 7812 UC REGUL.12U/1A TO 220	FAIRCHILD	
4200290000 1	MC 7912 CP REGUL.-12U/1A TO220	* MC 7912 CP REGUL.-12U/1A TO220	MOTOROLA	
4200320000 1	LF 356 N B+	* LF 356 N B+	NS	
4200330000 1	LM 318 N B+	* LM 318 N B+	NS	
4300040000 1	2 N 918	* 2 N 918	SGS	
4300050000 1	2N2369 A	* 2N2369 A	MOTOROLA	
4300070000 1	2N2894	* 2N2894	MOTOROLA	
4300110000 1	BC560C /416C/415C/559C(BC214C)	* BC560C /413C/415C/559C(BC214C)	RTC	
4300130000 1	BFR 99	* BFR 99	MOTOROLA	
4300150000 1	MPS 2369	* MPS 2369	MOTOROLA	
4300190000 1	BC550C /414C/413C/549C(BC184C)	* BC550C /414C/413C/549C(BC184C)	RTC	
4300570000 1	BC 327-25 TO 92 (2N2907)	* BC 327-25 TO 92 (2N2907)	ITT	
4300580000 1	BC 337-25 TO 92 (2N2222)	* BC 337-25 TO 92 (2N2222)	ITT	
4300600000 1	MPS 3640	* MPS 3640	MOTOROLA	
4300610000 1	BF 506	* BF 506	MOTOROLA	
4300720000 1	BFY 90	* BFY 90	RTC	
4400080000 1	2N4416 CODE ACHAT	* 2N4416 PURCHASE CODE	*930849	
4500020000 1	IN4151	* IN4151	FU'ITT'	
4500040000 1	IN4004	* IN4004	ITT	
4500310000 4	1 N 4448	* 1 N 4448	ITT	
4500450000 1	BB 409 (STANDARD).....	* BB 409 (STANDARD).....	SIEMENS	
4500452200 1	BB 409 ENTRE 9&11.5PF A 11V CE	* BB 409 INPUT 9&11.5PF A 11V IC	ADRET C.ENTREE.	
4500540000 1	1N6263 D035 (EX ESM247&246)	* 1N6263 (SUBSTIT. ESM247&246)	RTC	
4600030000 1	ZPD5.1	* ZPD5.1	ITT	
4600050000 1	ZPD 6.2	* ZPD 6.2	ITT	
4600080000 1	ZPD6.8	* ZPD6.8	ITT	
4600170000 1	ZPD 10	* ZPD 10	ITT	
4800060000 1	2N2219	* 2N2219	RTC	
4800080000 1	2N2905	* 2N2905	RTC	
5300460000 1	100MMH ORE 53870 DEL 1025-68	* 100MMH ORE 53870 DEL 1025-68	OREGA DELEVAN	
6500530000 1	CAPUCHON GRIS D14 REF 040-3010	* GREY CAP D14 REF 040-3010	ELMA	
6500570000 1	D21 CADRAN VIERGE D53 042-4020	* D21 BLANK FACE D53 042-4020	ELMA	
6500580000 1	21 BOUTON BL/GRIS 6 050-4441	* 21 BL/GREY BUTTON 6 050-4441	ELMA	
6500600000 1	21 CAPUCHON GR/CLAIR 040-4110	* 21 BRIGHT GREY CAP 040-4110	ELMA	
6500610000 1	10 CAPUCHON GR/CLAIR 040-2110	* 10 BRIGHT GREY CAP 040-2110	ELMA	
6500720000 1	10 BOUTON BL/GRIS 3 050-2141	* 10 BUT. BLUE/GREY 3 050-2141	ELMA	

Garantie et Assistance - Warranty and Assistance

Ce produit ADRET ELECTRONIQUE est garanti pour une durée d'un an à compter de la date de livraison.

La garantie s'applique aux appareils ayant subi des dommages mécaniques causés lors de l'expédition en partance de ADRET ELECTRONIQUE ou présentant, à la suite de défaillance d'un élément ou d'un sous-ensemble, des caractéristiques non conformes aux spécifications techniques. Sont toutefois exclus de la garantie les dommages occasionnés par une utilisation anormale de l'instrument.

Le client s'engage, pour sa part, à ne pas intervenir sur le produit pendant la période de garantie sous peine de la perdre définitivement. Le retour et la réexpédition de l'appareil lors d'une opération de maintenance sous garantie sont pris en charge pour moitié par ADRET ELECTRONIQUE.

Passé le délai de garantie, la Société reste bien entendu au service de ses clients en leur offrant son concours pour toutes éventuelles opérations de maintenance.

Pour tous renseignements complémentaires, veuillez contacter votre représentant ADRET le plus proche, les coordonnées de nos principaux agents étant données dans le tableau ci-dessous.

The ADRET ELECTRONIQUE product is guaranteed for a period of one year from the date of delivery.

The warranty applies to equipment with mechanical damage sustained during shipping from ADRET ELECTRONIQUE, or failing to conform to the technical specification due to faulty components of sub-assemblies. The warranty does not cover damage caused by incorrect use of the instrument.

The client for his part undertakes not to interfere with the equipment during the warranty period, failing which the warranty is rendered void. One half of the cost of returning and re-shipping the equipment for maintenance under warranty will be met by ADRET ELECTRONIQUE.

After expiry of the warranty period, the Company will of course remain at the service of its customers and will offer its help to them for any maintenance work that may be necessary.

For any further information, please contact your nearest ADRET representative. The addresses of our main agents are given in the table below.

Réseau commercial ADRET - ADRET commercial network

FRANCE

Société BASCOUL ELECTRONIQUE
31200 TOULOUSE - 35, rue du luchet
Tél : 61 48 99 29 - Téléx : 521 508
33600 BORDEAUX PESSAC - 76 Avenue Pasteur
Tél : 56 45 01 90 - Téléx : 541 720

Société DIMEL Immeuble "Le Marino"
83000 TOULON - Avenue Claude Farrère
Tél : 94 41 49 63 - Téléx 430 093

JCF ELECTRONIQUE
74019 ANNECY CEDEX - Annecy le Vieux - BP 964
Tél : 50 23 63 64 - Téléx : 385 417

Société SOREDIA
"Les Guittais" - Chatillon sur Seiche
35015 RENNES CEDEX - BP 1413
Tél : 99 50 50 29 - Téléx : 950 359

AFRIQUE DU SUD - SOUTH AFRICA

K.B.A. INSTRUMENTATION PTY
P O BOX 41062 - Avenue Sandton 2199
CRAIGHALL TRANSVAAL 2024
Tél : (11) 788 1700/05 - Téléx : 422 033

ALLEMAGNE - GERMANY

S.P.E.A. GmbH - Schützenweg 62
D 6305 GROSSEN BUSECK
Tél : (64) 08 2081 Code 299 - Téléx : 484 296

ARGENTINE - ARGENTINA

RAYO ELECTRONICA
1092 BUENOS AIRES - Belgrano 990
Tél : (01) 381779 - Téléx : 22153

AUSTRALIE - AUSTRALIA

VICOM INTERNATIONAL PTY
57 City Road - South Melbourne
VICTORIA 3205
Tél : (03) 626 931 - Télex : 36935
Telefax : (61) 3622325

AUTRICHE et EUROPE DE L'EST - EAST EUROPE

S.P.E.A. GES.m.b.H. Stiftgasse 27
A 1100 WIEN - Tél : (222) 62 61 41
Telex : 116 084

BELGIQUE et LUXEMBOURG - Belgium and Luxembourg

SAIT ELECTRONICS
B 1190 BRUXELLES - 66 Chaussée de Ruisbroek
Tél : (02) 376 20 30 Code 280 - Télex : 61807

BRESIL - BRAZIL

GRADIENTE ELECTRONICA LTDA
Staub Agency Division - Rua Sorocaba 316
CEP 22271 BOTAFOGO - RIO DE JANEIRO
Tél : (21) 286 8722 - Télex : 21 21131

CANADA

AIM ELECTRONICS INC
376 Churchill Avenue - Suite 108
OTTAWA - ONTARIO K1Z 5C3
Tél : (613) 7228286 Code 284
(514) 3322762 (Montréal) - Télex : 534862

DANEMARK - DENMARK

METRIC A.S.
Skodsborgvej 305 - D. K. 2850 - NAERUM
Tél : (02) 80 4200 Code 285 - Télex : 37163

ESPAGNE - SPAIN

TELCO
Gravina 27 - MADRID
Tél : (01) 231 71 01 Code 279 - Télex : 27348

ETATS-UNIS - UNITED STATES

COMSTRON CORP
10 Hub Drive - MELVILLE - NEW YORK 11747
Tél : (516) 756 1100
Télex : 4973525
Telefax : (516) 756 1167

FINLANDE - FINLAND

ORBIS OY
Sorolantie 16 - P O BOX 15 - 00421 HELSINKI 42
Tél : (358) 05664066 Code 283 - Télex : 123134

GRANDE-BRETAGNE - GREAT BRITAIN

RACAL DANA
Duke Street - WINDSOR BERKS SL4 1SB
Tél : (75) 38 68 101 Code 274 - Télex : 847013

GRECE - GREECE

SCIENTIFIC ENTERPRISES C.O.
45, Agion Saranta St - 18 346 ATHENES
Tél : (1) 482 34 21 - Télex : 221770

HONG KONG

I N F A
19 Austin Road - TSIMSHATSUI, KOWLOON - HONG KONG
Tél : (852) 5 7211151 - Télex : 54016

INDE - INDIA

HINDUSTAN INSTRUMENTS LTD
603 Vishal Bhavan - 95 Nehru Place
NEW DELHI 110 019
Tél : (11) 6410529 - Télex : 31 61209

ITALIE

LP INSTRUMENTS
Paolo Pallia 5 - 20139 MILANO
Tél : (02) 5392440 Code 277 - Télex : 315085

KOWEIT - MOYEN ORIENT

ABDUL AZIZ YOUSUF ESSA et CO WLL
P O BOX 3562 - SAFAT
Télex : 23576

NORVEGE - NORWAY

TERCO A.S.
P O BOX 98 - N 1540 VESTBY
Tél : (02) 951000 Code 287 - Télex : 74464

NOUVELLE ZELANDE - NEW ZEALAND

NEECO
17 Adelaide Road - P O BOX 9749
NEWTOWN WELLINGTON
Tel : (64) 4858689 - Telex : NX 3582
Telefax : (64) 4850510

PAYS-BAS - NETHERLAND

CN ROOD BV
11.13. Cort V.D Lindenstraat - P O BOX 42
2280 RIJSWIJK
Tél : (70) 996 360 Code 281 - Télex 31238

PORTUGAL

RUALDO LDA
9 - 15 Rua de San Jose - 1198 LISBOA CODEX
Tél : (01) 373461 Code 286 - Télex : 16447

REP. POPULAIRE DE CHINE - CHINA

COMPAGNIE OLIVIER
Peking Hôtel - Gui Bin Shi n°3 - BEIJING
Télex : 22375

SINGAPOUR - SINGAPORE

COSMOTEC ENTERPRISES LTD
70 Bendemeer Road - Hiap Huat House 05-04
SINGAPOUR 1233
Tél : (65) 2967766 - Télex 36992

SUEDE - SWEDEN

SAVEN AB
Nytorsvagen 30 - P O BOX 504 - S 18325 TABY
Tél : 87921100 Code 282 - Télex : 12986

SUISSE - SWITZERLAND

AMOTEC ELECTRONIC AG
Roßfluhstraße 38 - 8702 ZOLLIKON
Tél : (01) 3915630 - Télex : 816906
Telefax : (01) 3915633

TAIWAN

CATHAY ENTERPRISE CO Ltd
P O BOX 1778 - 102 Thun hua Road - TAIPEI
Tél : (886) 7310558 - Télex : 22392
Telefax : (886) 7732227

0722301300

09/1986